

## Wheel Balancer

# Installation and Operation Manual

Manual P/N 5900163 — Manual Revision C1 — March 2020

Model:

- DST30P



Designed and engineered in Southern California, USA. Made in China.

 **DANGER**

**Read the *entire contents* of this manual *before* using this product.** Failure to follow the instructions and safety precautions in this manual can result in serious injury or death. Make sure all other operators also read this manual. Keep the manual near the product for future reference. ***By proceeding with installation and operation, you agree that you fully understand the contents of this manual and assume full responsibility for product use.***

**Manual.** DST30P Wheel Balancer, *Installation and Operation Manual*, Manual P/N 5900163, Manual Revision C1, released March 2020.

**Copyright.** Copyright © 2020 by BendPak Inc. All rights reserved. You may make copies of this document if you agree that: you will give full attribution to BendPak Inc., you will not make changes to the content, you do not gain any rights to this content, and you will not use the copies for commercial purposes.

**Trademarks.** BendPak, the BendPak logo, Ranger, and the Ranger logo are registered trademarks of BendPak Inc. All other company, product, and service names are used for identification only. All trademarks and registered trademarks mentioned in this manual are the property of their respective owners.

**Limitations.** Every effort has been made to have complete and accurate instructions in this manual. However, product updates, revisions, and/or changes may have occurred since this manual was published. BendPak Ranger reserves the right to change any information in this manual without incurring any obligation for equipment previously or subsequently sold. BendPak Ranger is not responsible for typographical errors in this manual. Feel free to contact us at any time to get the latest information about any product: [rangerproducts.com](http://rangerproducts.com).

**Warranty.** The BendPak Ranger warranty is more than a commitment to you: it is also a commitment to the value of your new product. For full warranty details, contact your nearest BendPak Ranger dealer or visit [bendpak.com/support/warranty](http://bendpak.com/support/warranty). Go to [bendpak.com/support/register-your-product/](http://bendpak.com/support/register-your-product/) and fill out the online form to register your product (be sure to click **Submit**).

**Safety.** Your new product was designed and manufactured with safety in mind. Your safety also depends on proper training and mindful operation. Do not set up, operate, maintain, or repair the unit without reading and understanding this manual and the labels on it; **do not use this product unless you can do so safely!**

**Owner Responsibility.** In order to maintain your product properly and to ensure Operator safety, it is the responsibility of the product owner **to read and follow these instructions**:

- Follow all installation, operation, and maintenance instructions.
- Make sure product installation conforms to all applicable local, state, and federal codes, rules, and regulations, such as state and federal OSHA regulations and electrical codes.
- Read and follow all safety instructions. Keep them readily available for Operators.
- Make sure Operators are properly trained, know how to safely operate the unit, and are properly supervised.
- Do not operate the product until you are certain that all parts are in place and operating correctly.
- Carefully inspect the product on a regular basis and perform all maintenance as required.
- Service and maintain the unit only with approved replacement parts.
- Keep the manual with the product and make sure all labels are clean and visible.
- **Only use this product if it can be used safely!**

**Unit Information.** Enter the Model Number, Serial Number, and the Date of Manufacture from the label on your unit. This information is required for part or warranty issues.

Model: \_\_\_\_\_

Serial: \_\_\_\_\_

Date of Manufacture: \_\_\_\_\_

		Santa Paula, CA USA <a href="http://www.rangerproducts.com">www.rangerproducts.com</a>	
MODEL NUMBER			
SERIAL NUMBER			
VOLTAGE			
DESCRIPTION			
DATE OF MFG.			
		<b>DANGER!</b> Disconnect Power Before Servicing	
		 	
WARRANTY VOID IF DATA PLATE IS REMOVED PN 5905279			

---

# Table of Contents

<b>Introduction</b> .....	<b>3</b>	<b>Operation</b> .....	<b>23</b>
<b>Shipping Information</b> .....	<b>4</b>	<b>Maintenance</b> .....	<b>39</b>
<b>Safety Considerations</b> .....	<b>4</b>	<b>Troubleshooting</b> .....	<b>40</b>
<b>Components</b> .....	<b>6</b>	<b>Wiring Information</b> .....	<b>43</b>
<b>FAQ</b> .....	<b>8</b>	<b>Labels</b> .....	<b>44</b>
<b>Specifications</b> .....	<b>9</b>	<b>Parts</b> .....	<b>46</b>
<b>Installation Checklist</b> .....	<b>10</b>	<b>Maintenance Log</b> .....	<b>58</b>
<b>Installation</b> .....	<b>11</b>		

## Introduction

This manual describes the BendPak Ranger DST30P Wheel Balancer, which is a computer-controlled Wheel Balancer that provides fast, accurate Wheel balancing for a wide variety of Wheels.

More information about BendPak Ranger products is available at [rangerproducts.com](http://rangerproducts.com).

***This manual is mandatory reading for all users*** of the DST30P, including anyone who sets up, operates, maintains, or repairs it.

** DANGER** Be very careful when setting up, operating, maintaining, or repairing this equipment; failure to do so could result in property damage, product damage, injury, or (in very rare cases) death. Make sure only authorized personnel operate this equipment. All repairs must be performed by an authorized technician. Do not make modifications to the unit; this voids the warranty and increases the chances of injury or property damage. Make sure to read and follow the instructions on the labels on the unit.

Keep this manual on or near the equipment so that anyone who uses or services it can read it.

Technical support and service for your Wheel Balancer is available from your distributor or by calling **BendPak Ranger at (805) 933-9970**. You may also call regarding parts replacement (please have the serial number and model number of your unit available).

---

# Shipping Information

Your equipment was carefully checked before shipping. Nevertheless, you should thoroughly inspect the shipment **before** you sign to acknowledge that you received it.

When you sign the bill of lading, it tells the carrier that the items on the invoice were received in good condition. **Do not sign the bill of lading until after you have inspected the shipment.** If any of the items listed on the bill of lading are missing or damaged, do not accept the shipment until the carrier makes a notation on the bill of lading that lists the missing or damaged goods.

If you discover missing or damaged goods **after** you receive the shipment and have signed the bill of lading, notify the carrier at once and request the carrier to make an inspection. If the carrier will not make an inspection, prepare a signed statement to the effect that you have notified the carrier (on a specific date) and that the carrier has failed to comply with your request.

It is difficult to collect for loss or damage after you have given the carrier a signed bill of lading. If this happens to you, file a claim with the carrier promptly. Support your claim with copies of the bill of lading, freight bill, invoice, and photographs, if available. Our willingness to assist in helping you process your claim does not make us responsible for collection of claims or replacement of lost or damaged materials.

## Safety Considerations

**Read this manual carefully before using your new product.** Do not set up or operate the product until you are familiar with all operating instructions and warnings. Do not allow anyone else to operate the product until they are also familiar with all operating instructions and warnings.

### Safety Information

Please note the following:

- The product is a Wheel Balancer. **Use it only for its intended purpose.**
- The product should only be operated by trained, authorized, and supervised personnel. Keep children and untrained personnel at least 30 feet away from the unit while it is in use.
- You **must** wear OSHA-approved (Publication 3151) Personal Protective Equipment at all times when installing, using, maintaining, or repairing the Balancer. Leather gloves, steel-toed work boots, ANSI-approved eye protection, back belts, and hearing protection **are mandatory.**
- Keep hair, jewelry, and clothing away from the Balancer. If they get caught in the Balancer mechanism, they could injure the wearer and damage the Balancer.
- When a Wheel is spinning, keep away from it.
- Do not use the product while tired or under the influence of drugs, alcohol, or medication.
- Do not use the product in the presence of cigarette smoke, dust, or flammable liquids or gases. Use the product indoors in a well-ventilated area.
- Do not make any modifications to the product; this voids the warranty and increases the chances of injury or property damage.
- Make sure all Operators read and understand the *Installation and Operation Manual*. Keep the manual near the device at all times.

- 
- Make a visual inspection of the product ***before using it each time***. Do not use the product if you find any missing or damaged parts. Instead, take the unit out of service, then contact an authorized repair facility, your distributor, or **Ranger Products at (805) 933-9970**.
  - BendPak Ranger recommends making a ***thorough*** inspection of the product once a month. Replace any damaged or severely worn parts, decals, or warning labels.

## Symbols

Following are the symbols that may be used in this manual:



**DANGER**

Calls attention to a hazard that **will** result in death or injury.



**WARNING**

Calls attention to a hazard or unsafe practice that **could** result in death or injury.



**CAUTION**

Calls attention to a hazard or unsafe practice that could result in personal injury, product damage, or property damage.

**NOTICE**

Calls attention to a situation that, if not avoided, could result in product or property damage.



**Tip**

Calls attention to information that can help you use your unit better.

## Liability Information

BendPak Ranger assumes **no** liability for damages resulting from:

- Use of the equipment for purposes other than those described in this manual.
- Modifications to the equipment without prior, written permission from BendPak Ranger.
- Injury or death caused by modifying, disabling, overriding, or removing safety features.
- Damage to the equipment from external influences.
- Incorrect operation of the equipment.

# Components

Balancer components include:

- **Control Panel.** Controls the Balancer and displays information.
- **Hood.** Covers the Wheel while it spins. Lowering the Hood starts the Wheel spinning.
- **Inner Arm / Distance Ruler.** Pulls out to measure the distance from the side of the Balancer to the Inner Edge of the Wheel. Includes a ruler that shows distance in Centimeters.
- **On/Off Switch.** Turns the Balancer on and off.
- **Trays.** Storage for Clip-On Weights and other items you want to have handy.
- **Adhesive Weight Dispensers.** Dispenses your Adhesive Weights.
- **Side Storage Rack.** Holds more items you want to have handy.
- **Cone Hangers.** Hold your Mounting Cones when not in use.
- **Anchor Bolt Holes.** Used to anchor the Balancer to the ground.
- **Brake Pedal.** Step on to hold the Wheel in place.

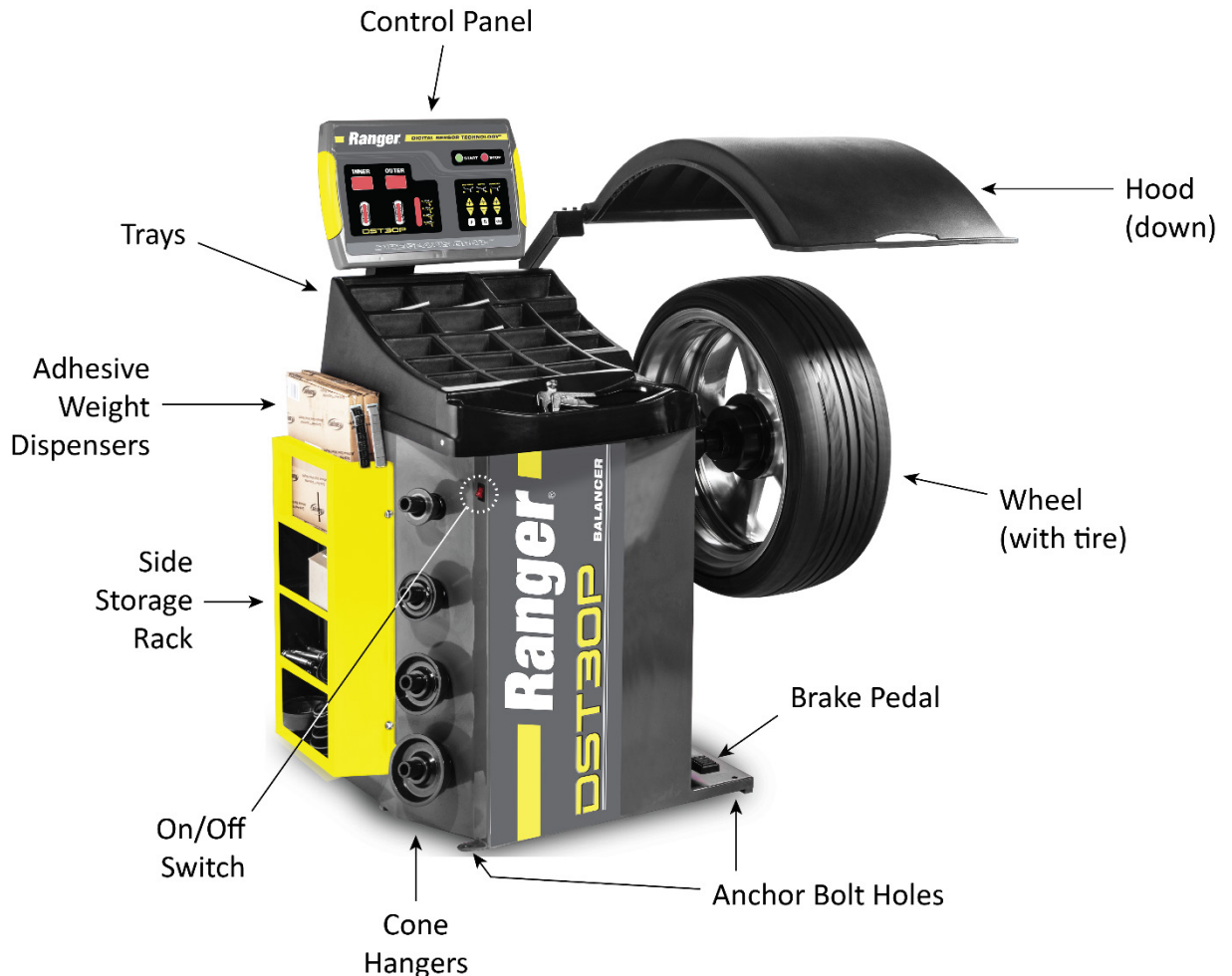

*The Inner Arm/Distance Ruler is not visible in this view.*



---

Balancer accessories include:

- **Quick Nut.** Holds the Wheel on the Balancer.
- **Hex Key Wrench Set.** Used during installation; included with the Balancer.
- **Anchor Bolts.** Anchor the Balancer to the floor at the desired location.
- **Wheel Weight Tool.** Used to put on and take off Clip-On Weights.
- **Mounting Spring.** Secures the Wheel when using Rear- and Dual-Cone Mounting.
- **Mounting Cone assortment.** Support a wide range of Wheel sizes.
- **Caliper.** Used to measure the Width of a Wheel. Comes in a box of its own.
- **Spacer Ring.** Attaches to the Shaft Flange; used for larger Wheels only.
- **Calibration Weight.** 100 grams / 3.5 ounces. Used during the self-calibration procedure.

All of the Balancer accessories are shown and identified in [Accessories](#).

Other terms you need to understand include:

- **Wheel.** A circular **metal** piece that attaches to an axle and turns.
- **Tire.** A circular *rubber* piece that surrounds and attaches to a Wheel; more specifically, to the Rim, the part of the Wheel that directly touches the Tire. Most Tires are pneumatically inflated (filled with a gas, such as air, hydrogen, helium, or nitrogen) and made out of rubber (synthetic or natural).
- **Rim.** The part of a Wheel that directly attaches to a Tire; almost always the outer portion of the Wheel. Because modern Wheels are frequently created from a single piece of metal, “Wheel” and “Rim” are sometimes used interchangeably.
- **Imbalance.** An unbalanced weight distribution in a Wheel; it can cause uneven rotation. To correct an imbalance, a weight must be applied **opposite** the imbalance.
- **Planes.** When a Wheel is figuratively divided down the middle into two sections, it creates two planes; called Inner and Outer. Balancing is more effective when planes are analyzed for imbalance separately (and addressed separately), called Dynamic Balancing.
- **Clip-On Weights.** Metal weights that are held in place on the Wheel by clipping them to the Inner or Outer Edge. Older Clip-On Weights *made of lead* should **not** be used as they are a hazard to the environment; they are also illegal to use in many countries and some states in the U.S. The Clip-On Weights that come with the Balancer are **not** made of lead.
- **Adhesive Weights.** Weights that are flat and held in place with adhesive; they get placed on the Inner, Outer, or Center Plane. Adhesive Weights come in both black and gray, making them harder to see and thus not interfering with the attractiveness of the Vehicle’s Wheels/Rims.
- **Placement Indicators.** Light up when the best weight location is reached.
- **Balancing Modes.** The Balancer supports Dynamic, Static, and Aluminum Alloy Balancing.
- **Dynamic Balancing.** Balancing a steel Wheel where each of the two planes are analyzed separately. If there is an imbalance, the two planes are brought back into balance separately. Dynamic Balancing is a more recent technology than Static Balancing and generally produces a better balance.
- **Static Balancing.** Balancing a Wheel as a whole; that is, on a single plane only. This is an older method of balancing and is generally not as effective as Dynamic Balancing. Static Balancing is required for motorcycle Wheels and older Wheels that are 4 inches wide or less; also used if only Adhesive Weights can be attached on the Center Plane of the Wheel.
- **Aluminum Alloy Balancing.** Balancing Wheels made of aluminum alloy. The Weights are placed differently on these Wheels, so you need to know where you want to put the Weights and select the appropriate ALU Mode. ALU Modes generally use Adhesive Weights, which are less visible than Clip-On Weights.

---

# Frequently Asked Questions

**Question:** What does a Wheel Balancer do?

**Answer:** They correct the imbalance of a Wheel. If you drive a Vehicle with imbalanced Wheels, the Vehicle could experience noise, vibrations, wobbling, reduced or uneven Tire tread wear, and some components could wear out sooner rather than later. Getting a Vehicle's Wheels balanced may also increase its mileage.

**Q:** Is Wheel Balancing the same as Wheel Alignment?

**A:** No. When you *balance* a Wheel, you fix a weight distribution problem that can cause Wheel wobble, uneven Tire wear, and Vehicle vibration. This is done by putting Weights on the Wheel in appropriate locations.

When you *align* a Wheel, you are adjusting the angles of the Wheels back to the manufacturer's recommendation, which reduces Tire wear and ensures the Vehicle drives straight and true (that is, the Vehicle does not pull to one side).

**Q:** Where can I put my Wheel Balancer?

**A:** What you want is a flat Concrete floor with room around it that is also near where you work on Wheels. You want it off the beaten path, as you want to keep everyone away from the Balancer while it is in use. Most garages put their Wheel Balancers and Tire Changers near each other.

**Q:** Why are there two types of Weights?

**A:** Clip-On Weights are more visible. Adhesive Weights are lower profile and come in two colors so you can try to color match with the Rim, so they are less visible. Some Vehicle owners with expensive Wheels prefer Adhesive Weights because they are less visible.

**Q:** Why isn't there a plug on the end of the Power Cord?

**A:** The Balancer motor comes from the factory set for 220 VAC power. However, it is switchable to 110 VAC. Refer to **Connecting to Power** for complete instructions for switching between 220 and 110 VAC. Because 220 VAC plugs vary from location to location, no plug comes with the Balancer. Have your Electrician install an appropriate plug or have the Power Cord attached directly to the facility's power system.

**Q:** What Balancing Modes does the Balancer have?

**A:** The Balancer has five Balancing Modes: Dynamic, STA1, STA2, ALU1, and ALU2. Dynamic mode is used with steel Wheels, the two Static modes are for older, narrower Wheels or motorcycle Wheels, and the Aluminum modes are for Aluminum Alloy (non-steel) Wheels.

**Q:** How accurate are the weight values the Balancer displays?

**A:** By default, the Balancer rounds off to .25 ounces (~7 grams); this is because most weights sold in the U.S. come in .25 ounce increments. (Countries that use the metric system measure weight in grams; their weights come in 5 gram increments.) If you do not want rounded-off weight values, press and hold the **<5g** button on the Control Panel to see specific values.

**Q:** What do I do if I have a problem with the Balancer that I cannot solve?

**A:** Contact BendPak Ranger; we are here to help. Using a web browser, visit the **BendPak Support website**, click on **+ New support ticket**, and then fill in and submit a Support Ticket (make sure to click the **Submit** button at the bottom).



# Specifications

<b>Model</b>	<b>DST30P</b>
Data Entry	Manual
Motor	110 <i>or</i> 220 VAC, 50/60 Hz, 1 Ph, 1.5 HP
Working Temperature	-5°C to 40°C / 23°F to 104°F
Cycle Time	6 to 9 seconds
Balancing Modes	Dynamic / Static / Alloy
Maximum Rim Diameter	50 in / 1,270 mm
Maximum Tire Weight	150 lbs / 68 kg
Wheel Diameter Capacity	8 in to 30 in / 203 mm to 762 mm
Wheel Width Capacity	1.2 in to 20 in / 30 mm to 508 mm
Balancing Speed	180 RPM
Balancing Increments (default)	0.25 ounces / 7 grams
Accuracy (<5g button)	.035 ounces / 1 gram
Resolution (round off mode)	0.01 ounce, 1.4°
Height, Hood Up	65 in / 1,651 mm
Height, Hood Down	52 in / 1,321 mm
Width	48 in / 1,219 mm
Depth, Hood Up	40 in / 1,016 mm
Depth, Hood Down	41 in / 1,041 mm
Power Cord Length	58 in / 1,473 mm
Sound	< 70 dB

---

# Installation Checklist

Following are the steps needed to install the Balancer. Perform them in the order shown.

- 1. Review the installation Safety Rules.
- 2. Plan for Electrical Work.
- 3. Make sure you have the necessary Tools.
- 4. Select the Installation Site.
- 5. Make sure there is adequate Clearance on all Sides.
- 6. Unpack the Components.
- 7. Identify the Components on the Back of the Unit.
- 8. Install the Control Panel.
- 9. Install the Hood.
- 10. Install the Shaft.
- 11. Anchor the Unit.
- 12. Connect to a Power Source. ***Requires a licensed, certified Electrician.***
- 13. Test the Balancer.

---

# Installation

This section describes how to install your Balancer.

## Installation Safety Rules

***Pay attention at all times during installation.*** Use appropriate tools and equipment. Stay clear of moving parts. Keep hands and fingers away from pinch points.

Use caution when unpacking the Balancer from its shipping container and setting it up. The Balancer is heavy and the weight is not evenly distributed; dropping or knocking over the unit may cause equipment damage or personal injury.

**⚠ WARNING** You ***must*** wear OSHA-approved (publication 3151) Personal Protective Equipment at all times when installing, using, maintaining, or repairing the Balancer. Leather gloves, steel-toed work boots, ANSI-approved eye protection, back belts, and hearing protection ***are mandatory***.

Only allow experienced, trained technicians to install the Balancer. In particular, all electrical work ***must*** be done by a licensed, certified Electrician.

**⚠ CAUTION** Certain parts of installing the Balancer are difficult for just one person. BendPak Ranger strongly recommends having two or more persons work together to install the Balancer.

If you have to use an extension cord, make sure its current rating is equal to or greater than that of the equipment being used. Make sure the extension cord cannot be stepped on, run over, or pulled out. Extension cords are also a tripping hazard, so they must be secured.

## Plan for Electrical Work

The Balancer comes ***without*** a Plug on the end of the Power Cord. You must directly connect the Power Cord to the facility's electrical system or supply an appropriate Plug and have an Electrician attach it to the Power Cord.

**⚠ WARNING** All electrical work, such as attaching a Plug to the Power Cord, ***must be done by a licensed, certified Electrician*** in accordance with all applicable local electrical codes.

Refer to **Connecting to Power** for more information about how to connect the Balancer to a power source. Refer to **Wiring Information** for specific information about connecting the wiring on the end of the Power Cord.

## Tools

You may need some or all of the following tools:

- Hex wrench set (multiple hex wrenches come with the Balancer)
- SAE and Metric wrench sets; adjustable wrench
- Scissors, utility knife, or other cutting tool; hammer
- Forklift, Pallet Jack, or Shop Crane

## Finding a Location

Keep in mind the following when deciding on a location:

- **Power source.** The Balancer needs to be near an appropriate power source.
- **Floor.** The Balancer is best used on a flat, concrete floor. If the floor is unstable or not flat, the Balancer will not work correctly; the readings will not be right.
- **Accessibility.** You need some space to move the Wheels you are going to balance to and from the Balancer.
- **Danger.** When a Wheel is spinning on the Balancer, you need to keep people away from it. Do not set up the Balancer in a well-travelled area. Everyone except the Operator should be at least 30 feet away from the Balancer when it is in use.
- **No water.** The Balancer has electronic components. If the Balancer gets wet while turned on, those electronic components will most likely short circuit and have to be replaced.

**⚠ WARNING** Do not use the Balancer if it is sitting in water. You will almost certainly short circuit the electronic components in the Balancer and you could electrocute yourself.

## Clearances

A certain amount of space around the Balancer is required.

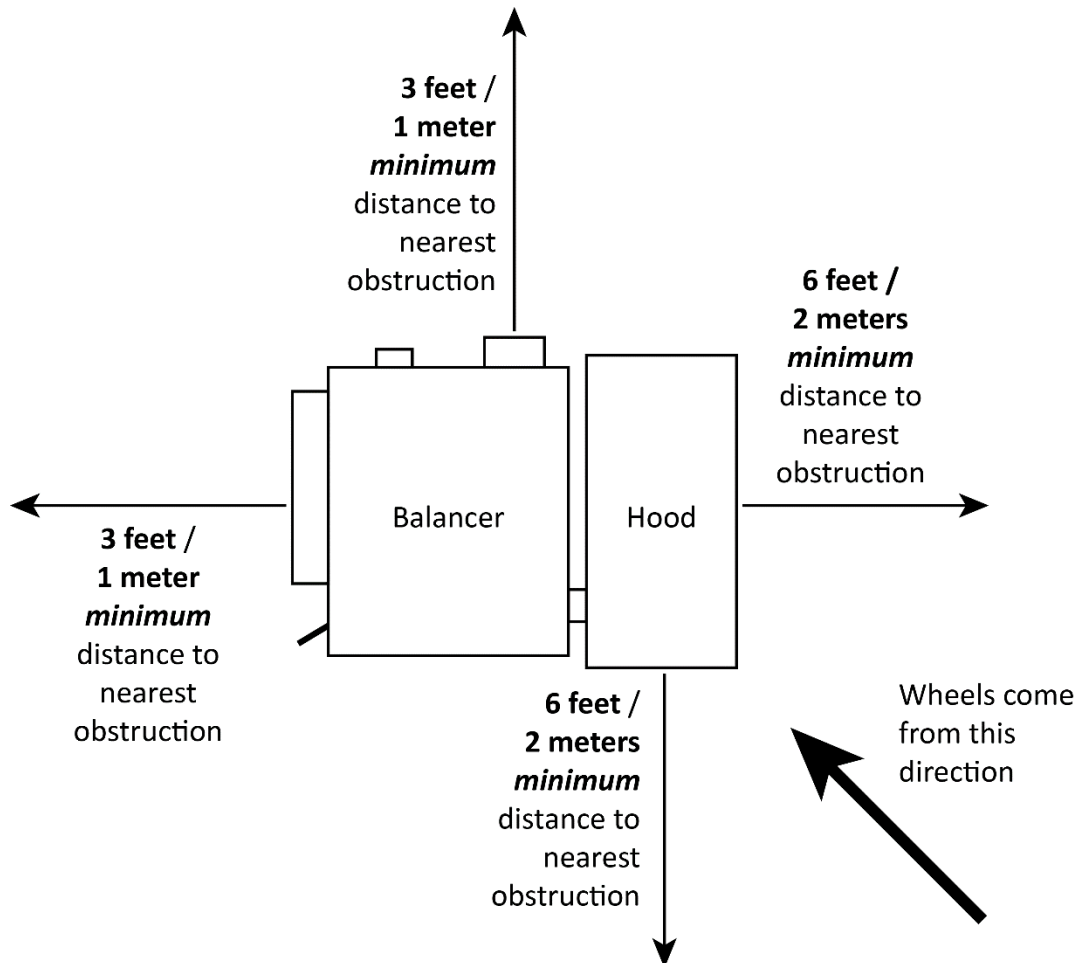

You also need enough room **above** the Balancer for the Hood to move up and down freely.

---

## Unpacking

Use caution when unpacking the Balancer from its shipping container. You do not want to damage the unit, misplace any of the components that come with it, or hurt anyone.

**⚠ CAUTION** Make sure to use an appropriate lifting device, such as a Forklift or Pallet Jack, to move the Balancer while it is on its pallet. Make sure only personnel who are experienced with material handling procedures are allowed to move the Balancer. The Balancer is heavy and the weight is not evenly distributed; dropping or knocking over the unit may cause equipment damage or personal injury. Do not lift the Balancer by the Shaft Housing; you will damage it.

We recommend you unpack the Balancer in the area where you are going to set it up.

### To unpack the Balancer:

1. Make sure you are wearing OSHA-approved (publication 3151) Personal Protective Equipment: leather gloves, steel-toed work boots, ANSI-approved eye protection, back belts, and hearing protection.
2. Remove the carton by flipping down the metal tabs **at the bottom** and pulling it off the Pallet, over the top of the Balancer.

Use care removing the carton; it is awkward and may change shape when moved.

3. Remove the plastic wrap, cardboard pieces, and other shipping components.
4. Remove the shipping bolts holding the Balancer to the Pallet.
5. *Lean the Balancer over and reach underneath it to **pull out the Accessory Box**.*
6. Move the Balancer off the Pallet, then move it to the desired location.

**Important:** Do not lift the Balancer by the Shaft Housing; it is not strong enough to bear the weight of the Balancer.

**⚠ CAUTION** Ranger recommends having at least two people move the Balancer; it is heavy. If it is dropped or falls, it could cause injuries and/or the Balancer could be damaged.

## Components on the Back of the Balancer

The Balancer has multiple components on the back that need to be installed and connected.

Balancer components on the back include:

- **Control Panel Mount Bar.** Holds the Control Panel. Connects to the back of the Balancer. The four Connectors coming out of the bottom of the Control Panel Mount Bar attach to the Control Panel Pins that are recessed on the back of the Balancer.
- **Hood Mount Box.** Connects to the back of the Balancer. Wiring inside the Hood Mount Box attaches to the Hood Wiring coming out of the back of the Balancer.
- **Hood Mount Bar.** Connects to the Hood Mount Box on one end and to the Hood on the other end.
- **Hood.** Connects to the Hood Mount Bar.

The following drawing shows the components on the back of the Balancer.

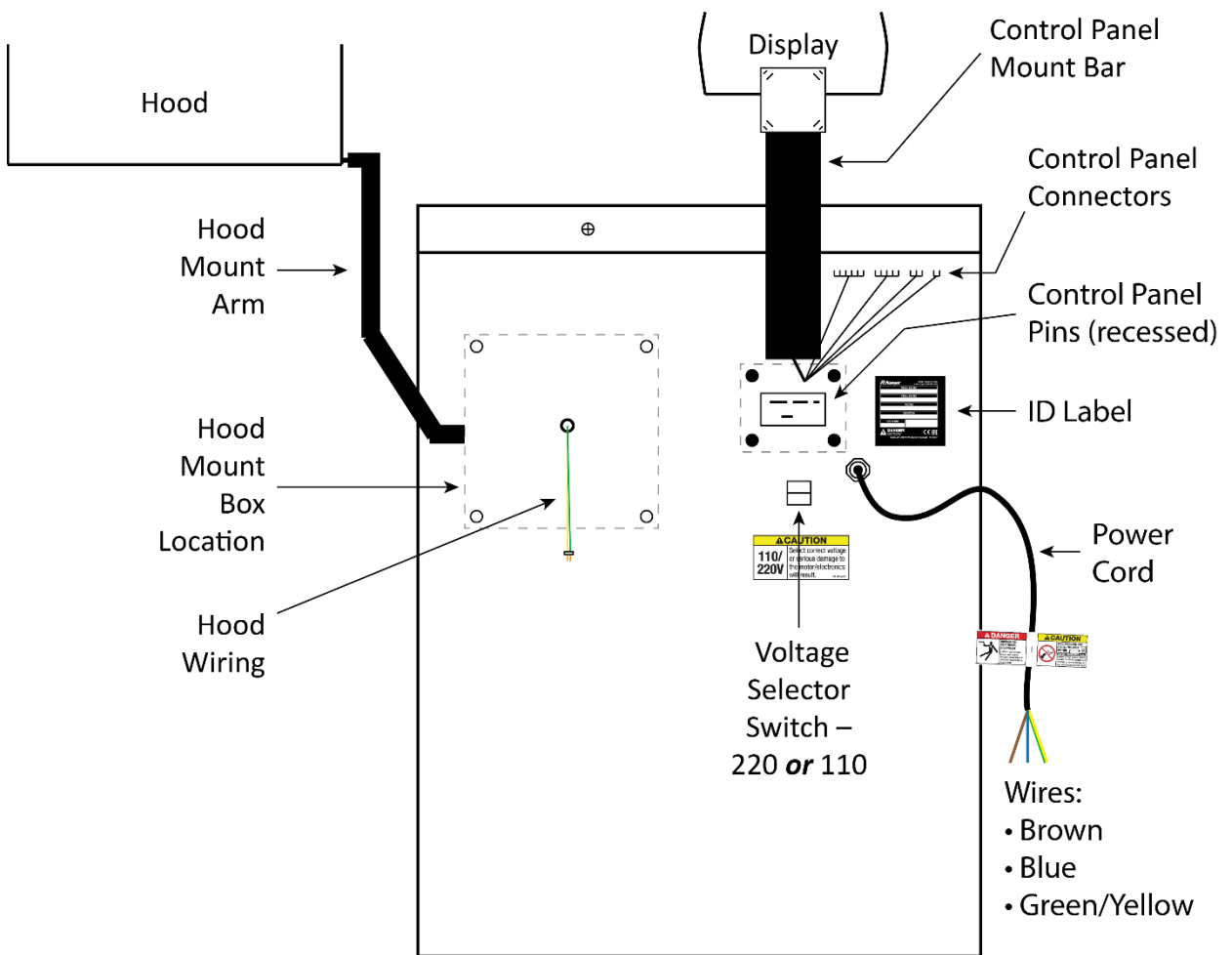

*Not necessarily to scale. Not all components shown.*



---

## Installing the Control Panel

The Control Panel lets you control the Balancer; it also displays Balancer information.



**Tip** BendPak Ranger recommends having **at least two people** perform this step: one person to hold the Control Panel Mount Bar in position and the other person to connect the wiring and re-install the bolts and washers.

### To install the Display Panel:

1. Locate the Control Panel Mount Bar.

The Control Panel Mount Bar is a single unit that includes the Display at the top and a plate at the bottom that attaches to the back of the Balancer.

2. Remove the four hex bolts, four split lock washers, and four standard washers that come installed on the back of the Balancer.

The bolts and washers come installed around the hole in the back of the Balancer where you can see the Control Panel Pins. Refer to the drawing on the previous page.

Keep the bolts and washers nearby; you will be putting them back very soon.

3. Put the plate at the bottom of the Control Panel Mount Bar next to the Control Panel Pins and hold it there.

This is the part where it is best to have two people: one person to hold the Control Panel Mount Bar in place and the second person to attach the white connectors and re-install the bolts.

4. Attach the Connectors, which are on the ends of the wires coming out of the bottom of the Control Panel Mount Bar, to the Control Panel Pins, which are recessed on the back of the Balancer.

There are four wires, each with a white Connector on the end of the wire. Each connector has a unique number of holes in it. These holes correspond to the Control Panel Pins.

Match the number of holes in the white Connector to the number of Control Panel Pins. When the number of pins **exactly matches** the number of holes, connect them.

For example, CN4 on the bottom row of the Control Panel Pins has **three pins**. Attach the white Connector that has **three holes** to CN4.

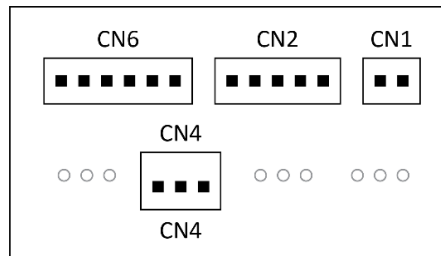

It may be necessary to adjust the wires to get the white Connectors into the right spot.

5. Push each white Connector in far enough so that you hear or feel it **click into place**.

The white Connector **must click into place** for the Control Panel to work correctly.

6. Re-install the four hex bolts, four split lock washers, and four standard washers.

Tighten the bolts securely, but **do not overtighten**.

**Important:** The plate at the bottom of the Control Panel Mount Bar includes a cover that comes installed. This cover can be removed if necessary.

## Installing the Hood

Installing the Hood requires you to install three separate items, in this order:

- Install the Hood Mount Box on the back of the Balancer.
- Attach the Hood Mount Arm to the Hood Mount Box.
- Attach the Hood to the top of the Hood Mount Arm.

### To install the Hood:

1. Locate the Hood Mount Box, the Hood Mount Arm, the Hood, and the bolts and washers needed to install them:
  - The Hood Mount Box comes in its own box that includes a bag with bolts, washers, and hex wrenches.
  - The Hood Mount Arm comes by itself, wrapped for shipping. There are two Set Screws already in place next to the Hole at the bottom of the Arm and two hex head bolts in place at the top.
  - The Hood also comes by itself, wrapped for shipping. It has a Rod on one corner that attaches to the top of the Hood Mount Arm.
2. **Starting with the Hood Mount Box**, remove the top (four small black screws).  
Keep the screws nearby; you will be reinstalling them soon. Don't lose them, they are small.
3. Use the four bolts, washers, and split lock washers from the bag to connect the Hood Mount Box to the back of the Balancer.

Tighten the four bolts securely.

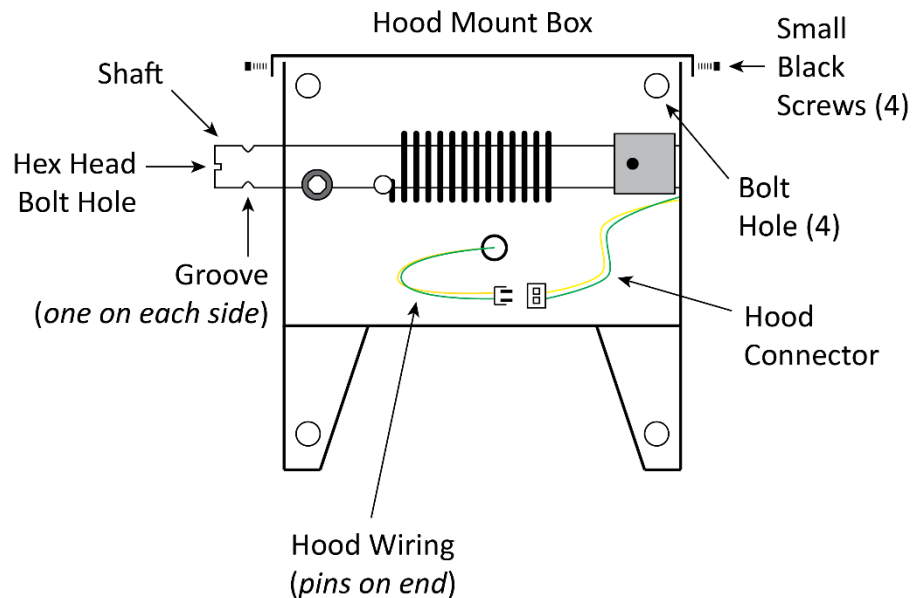

*Front not shown, for clarity. Not necessarily to scale. Not all components shown.*

4. Attach the pins on the Hood Wiring to the Hood Connector coming out of the right side of the Hood Mount Box.

The two pins go into the two holes in the connector. Make sure the connector and the pins click into position.

5. When the wiring is connected, reinstall the top of the Hood Mount Box.

6. Locate the Hood Mount Arm and the Hood.
7. **Starting with the bottom of the Hood Mount Arm**, slip the hole at the bottom over the Shaft on the left side of the Hood Mount Box. The Shaft is shown in the drawing on the previous page.  
Orient the Hood Mount Bar so that the Bumper goes up against the back of the Balancer.
8. Align the Set Screws on the bottom of the Hood Mount Arm with the Grooves in the Shaft, then tighten the Set Screws.

**Important:** The Set Screws need to be tightened down into the Grooves in the Shaft or the Hood will not work correctly.

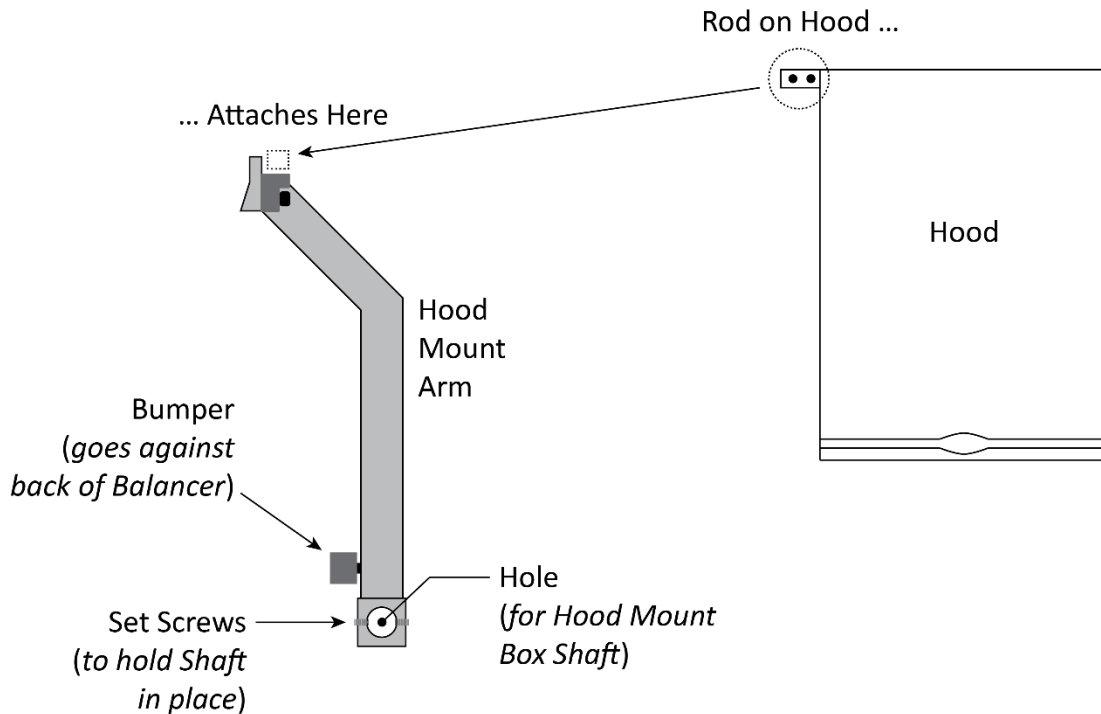

*Not necessarily to scale. Not all components shown.*

9. When the Set Screws are correctly installed, put the large washer and hex head bolt into place on the end of the Shaft (the Hex Head Bolt Hole) and tighten the hex head bolt.
10. **Switching to the top of the Hood Mount Arm**, remove the two hex bolts and the split lock washers.  
They come from the factory in place at the top of the Hood Mount Arm.
11. **Switching to the Hood**, put the Rod on one corner of the Hood into position next to the top of the Hood Mount Arm.  
The Handle in the Hood should be at the front of the Balancer.
12. Replace the two hex bolts and split lock washers you just removed; tighten them securely.
13. Test the Hood to make sure it moves back and forth smoothly.

## Installing the Shaft

The Shaft holds the Wheels you are balancing.



**Tip** BendPak Ranger recommends having **rags nearby**, the Shaft comes greased to protect it during transport. It's not 'if' you are going to get grease on you, but 'when'.

### To install the Shaft:

1. Locate the Shaft Assembly and the Mounting Bolt from the parts supplied with the Balancer.  
The Shaft Assembly ships with the Mounting Bolt inside the Threaded Shaft.
2. Clean the Shaft Assembly by removing the shipping grease and any dirt that has accumulated.
3. Put the Shaft Assembly into place next to the Shaft Housing and hold it there.

**Note:** We recommend aligning the Alignment Marks **before** putting the Shaft Assembly into place.

4. Put the Mounting Bolt into the end of the Threaded Shaft and *begin* tightening it.
5. *Before fully tightening* the Mounting Bolt, make sure the Alignment Marks are aligned (see drawing below).

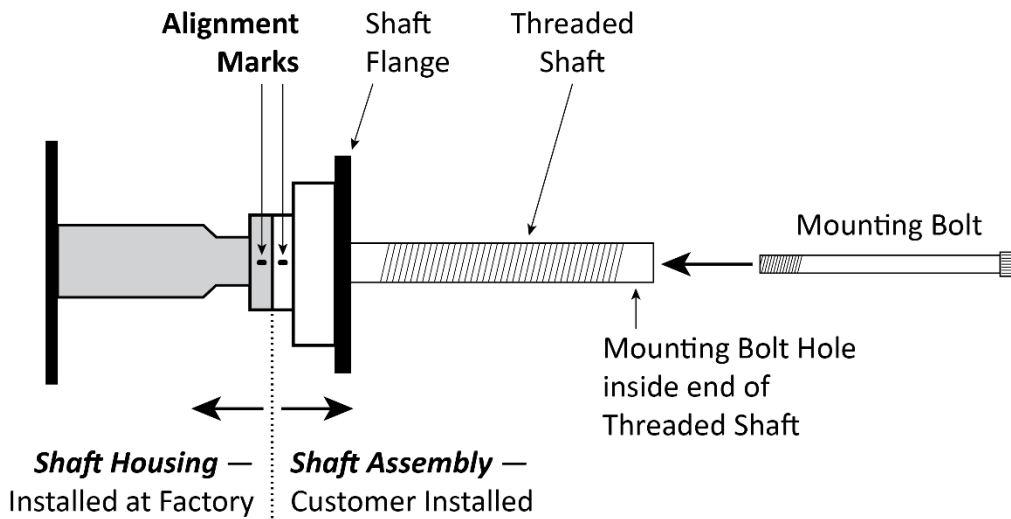

*Not necessarily to scale. Not all components shown.*

6. Securely tighten the Mounting Bolt into place.

## Anchoring the Balancer

The Balancer has three holes for Anchor Bolts, which hold the Balancer in place while you use it.

**Important:** You are **required** to bolt your Balancer into place, as movement during a Wheel Balance can cause bad readings.

### To anchor the Balancer:

1. Move the Balancer to the desired location.

Remember that you need to allow some space around the Balancer. Refer to [Finding a Location](#) for additional information.

2. Using the holes in the base as guides, drill the holes for the 3/8 in by 4 in Anchor Bolts.

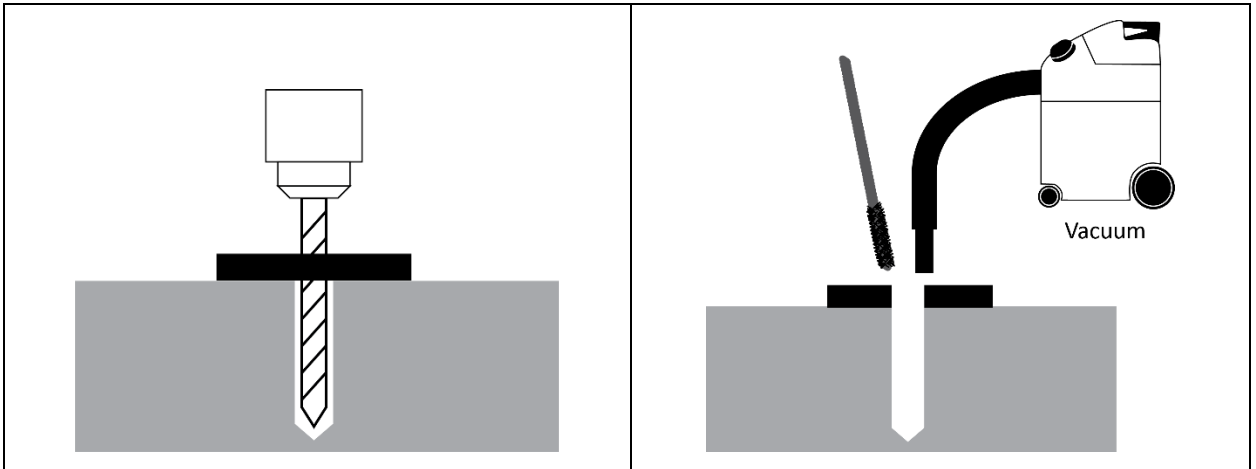

Go in straight; do not let the drill wobble. Use a carbide bit (conforming to ANSI B212.15-1994).

The diameter of the drill bit must be the same as the diameter of the Anchor Bolt. So if you are using a 3/8 in diameter Anchor Bolt, for example, use a 3/8 in diameter drill bit.

3. Vacuum each hole clean.

BendPak Ranger recommends using a vacuum to get the hole very clean.

Do **not** ream the hole. Do **not** make the hole any wider than the drill bit made it.

4. Make sure the Washer and Nut are in place, then insert the Anchor Bolt into the hole.

The Expansion Sleeve of the Anchor Bolt may prevent the Anchor Bolt from passing through the hole in the Base Plate; this is normal. Use a hammer or mallet to get the Expansion Sleeve through the Base Plate and into the hole.

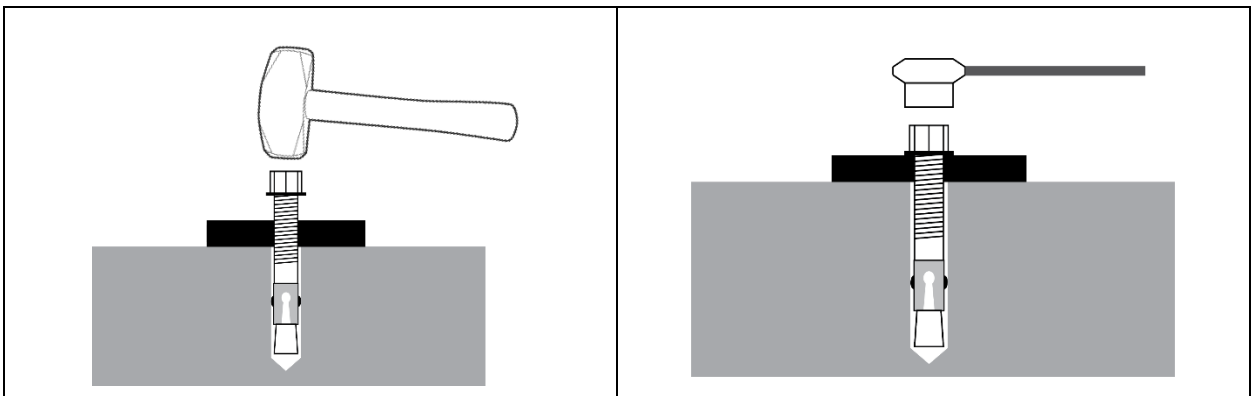

Even using a hammer or mallet, the Anchor Bolt should only go into the hole part of the way; this is normal. If the Anchor Bolt goes all the way in with little or no resistance, the hole is too wide.

Once past the hole in the Base Plate, the Anchor Bolt eventually stops going down into the hole as the Expansion Sleeve contacts the sides of the hole; this is normal.

5. Hammer or mallet the Anchor Bolt the rest of the way down into the hole.

Stop when the Washer is snug against the Base Plate.

6. Wrench each Nut **clockwise** until secure.

**Important:** Do **not** use an impact wrench to torque the Anchor Bolts.

Wrenching the Nut forces the Wedge up, forcing out the Expansion Sleeve and pressing it tightly against the Concrete.

## Connecting to Power

The Wheel Balancer motor comes configured to use a 220 VAC power source. It can be changed to use a 110 VAC power source, if desired.

**⚠ CAUTION** The setting of the Voltage Selector Switch on the back of the Balancer **must** match the power source. If you connect to 110 VAC power when the Switch is set to 220 V or you connect to 220 VAC power when the Switch is set to 110 V, you void your warranty and you could severely damage the Balancer.

**⚠ CAUTION** The Balancer uses electrical energy; if your organization has Lockout/Tagout policies, implement them once the Balancer is connected to power.

When you receive it from the factory, the motor in the Balancer is configured for 220 VAC power.

You can confirm this by checking the Voltage Selector Switch on the rear of the Balancer: it displays either **220 V**, which means the motor is configured to use 220 VAC power, or **110 V**, which means the motor is configured to use 110 VAC power.

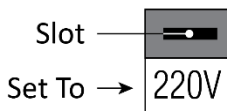

Voltage  
Selector  
Switch

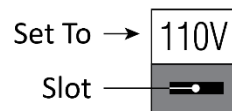

Voltage  
Selector  
Switch

**⚠ DANGER** **All** electrical work (including wiring a Plug to the end of a Power Cord) **must** be done by a licensed, certified Electrician. If you do not use a licensed, certified Electrician, you void your warranty and put everyone who uses the Balancer in danger of injury or, in rare cases, death.



---

**To use the Balancer with a 220 VAC power source:**

1. Confirm that the Voltage Selector Switch on the back of the Balancer is set to **220 V**.  
If it is set to **110 V**, use the Slot to move the Switch to 220 V.
2. Have a **licensed, certified Electrician** do **one** of the following:
  - Attach a 220 VAC NEMA 30 amp Plug to the end of the Power Cord.
  - Attach the Balancer directly to the facility's power system.
3. If you attach a Plug to the end of the Power Cord, plug the Balancer in to an appropriate 220 VAC outlet.

**To use the Balancer with a 110 VAC power source:**

1. Confirm that the Voltage Selector Switch on the back of the Balancer is set to **110 V**.  
If it is set to **220 V**, use the Slot to move the Switch to 110 V.
2. Have a **licensed, certified Electrician** do **one** of the following:
  - Attach a 110 VAC NEMA 20 amp Plug to the end of the Power Cord.
  - Attach the Balancer directly to the facility's power system.
3. If you attach a Plug to the end of the Power Cord, plug the Balancer in to an appropriate 110 VAC outlet.

Additional electrical information:

- **You must ground the unit.** Damage caused by improper electrical installation (not grounding the unit, for example) voids the warranty.
- Use a dedicated breaker for the Balancer.
- Electrical codes may require direct connection to the facility's power system (sometimes called "hard-wiring") when the Balancer is bolted to the floor. Consult a licensed, certified Electrician regarding the applicable codes for your location.

## Test the Balancer

You need to test the Balancer to make sure it is ready for normal operation.

### To test the Balancer:

1. Turn the On/Off switch to On.
2. On power up, **USA | 516** will appear in the Inner and Outer Windows, followed by default Wheel dimensions. (The “516” is the software version; this changes from time to time, so there’s no need to worry if the number is different on your Balancer.)

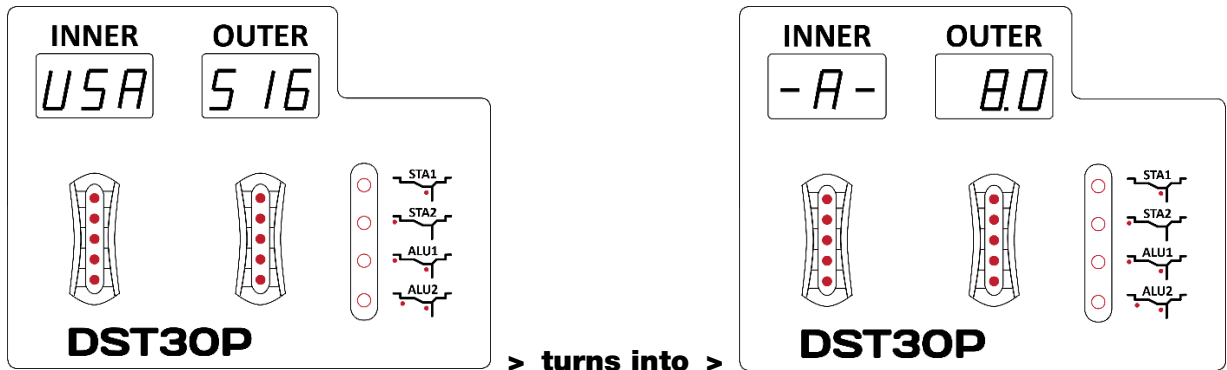

After a few seconds, the Inner and Outer Windows change to **-A- | 8.0**. (8.0 is the default value for Distance).

3. Mount a standard steel Wheel of a size you most often balance.  
Refer to [Mounting a Wheel](#) for specific mounting instructions.
4. Lower the Hood.  
The Wheel starts to spin clockwise when the Hood is lowered.
5. When the Wheel stops, it will display values in the Inner and Outer Windows.

Because we did **not** press the **F** button to change Balancing Modes, the Balancer performed a Dynamic Mode balance on the Wheel.

Because we did **not** enter any measurements for the Wheel we mounted, the Balancer used default values. Because real Wheel measurements were not used, you should ignore the values in the Inner and Outer Windows.

6. The Balancer has passed the test.

To get used to the Balancer, we recommend having all potential Operators balance *multiple non-customer* Wheels before working on customer Wheels. The Balancer may work differently than other Balancers you or the other Operators have used before.

---

# Operation

This section describes how to use your Balancer.

**⚠ DANGER** Being in close proximity to a Balancer is a serious endeavor with potentially life-threatening risks. Only trained, authorized, supervised personnel may be within 30 feet of the Balancer while it is in use. **Do not assume you are going to be safe using the Balancer this time just because nothing happened last time.**

## Usage Precautions

Keep the following in mind while using the Balancer:

- Make sure all Operators receive specific training in Wheel balancing **before** they are allowed to use the Balancer, that their training is verified through a testing program, and that all training is documented. All others, including children and untrained personnel, **must** be kept at least 30 feet away from the Balancer while it is in use.
- Make sure **new** Operators are trained and supervised in the use of the Balancer.
- Do not use the Balancer while tired or under the influence of drugs, alcohol, or medication.
- Make a visual inspection of the Balancer **before each use**. Do not operate the Balancer if you find any issues. Instead, take the unit out of service, then contact your dealer, visit [www.bendpak.com/support/](http://www.bendpak.com/support/), email [support@bendpak.com](mailto:support@bendpak.com), or call **(805) 933-9970**.
- Keep the work area around the Balancer clean and well lit. Dirty, cluttered, and dark work areas increase the chances of an accident happening.
- Do not remove the Trays on the top of the Balancer unless instructed to do so by BendPak Ranger Support. There are no user serviceable parts underneath.
- You **must** wear OSHA-approved (Publication 3151) Personal Protective Equipment at all times when installing, using, maintaining, or repairing the Balancer. Leather gloves, steel-toed work boots, ANSI-approved eye protection, back belts, and hearing protection **are mandatory**.

**⚠ WARNING** Always wear ANSI-approved eye protection. Although rare, an accident could cause significant injuries to your eyes.

- Do not use the unit in a wet environment or expose it to rain or excess moisture.
- If an extension cord is necessary, a cord with a current rating equal to or more than that of the Balancer must be used. Extension cords rated for less current than the equipment may overheat. Care should be taken to arrange the extension cord so that it will **not** be tripped over or pulled.
- Do not use the Balancer in the vicinity of open containers of flammable liquids.
- Clean the Balancer according to the instructions in **Maintenance**.
- **Study the entire Installation and Operation Manual** before using the Balancer.

## The Control Panel

The Control Panel lets you enter data for the Wheel being balanced and displays information.

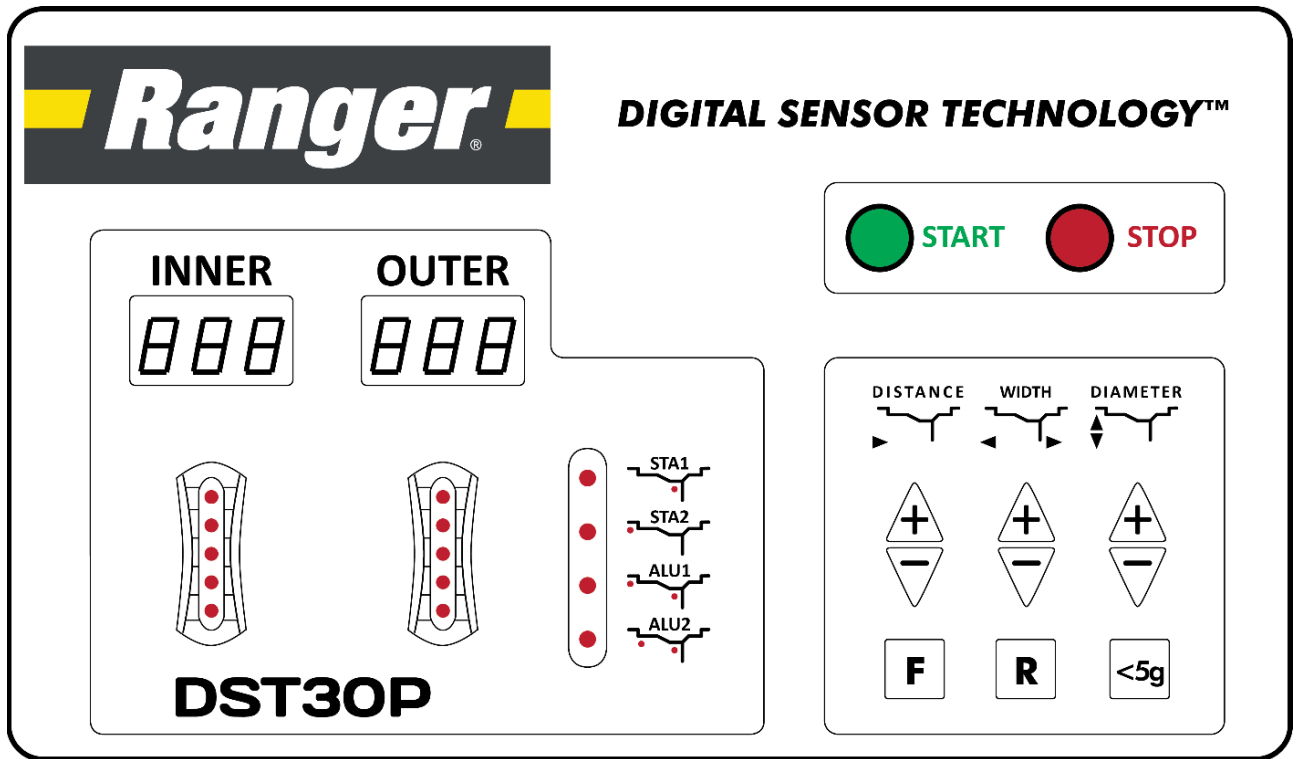

The parts of the Control Panel include:

- **Inner Window.** During the Measurements phase—*before* spinning the Wheel—this Window indicates which measurement needs to be entered. During the Weights phase—*after* spinning the Wheel—it shows the weight that needs to be added to the inner side of the Wheel, if any.  
The three measurements that need to be entered are:
  - *Distance.* Indicated by **-A-** on the Inner Window.
  - *Width.* Indicated by **-L-** on the Inner Window.
  - *Diameter.* Indicated by **-d-** on the Inner Window.
- **Outer Window.** During the Measurements phase, this Window shows the value you are entering. During the Weights phase, it shows the weight to be added to the outer side of the Wheel.
- **Indicators under Inner and Outer.** When Weight needs to be added to a Wheel, you turn the Wheel and watch the indicators under Inner or Outer, whichever side you are adding weight to. When all of the indicators are lit, press the Brake to hold the Wheel and then add the specified weight to Top Dead Center (also known as 12 o'clock high) on the Wheel.

- **Balancing Mode indicators.** STA 1, STA 2, ALU1, and ALU2. When a Balancing Mode is selected, the appropriate indicator to the left lights up. If **none** of the four indicators is lit, then Dynamic Mode is active.

Put another way, there is no indicator for Dynamic Mode. When no indicators are lit, which is the default when the Balancer is switched on, Dynamic Mode is active.

The Balancing Mode indicators also have diagrams to show where the weight goes when it is necessary to add weight. The diagrams are different for each Balancing Mode.

The red dots indicate where the weight goes for each Mode.

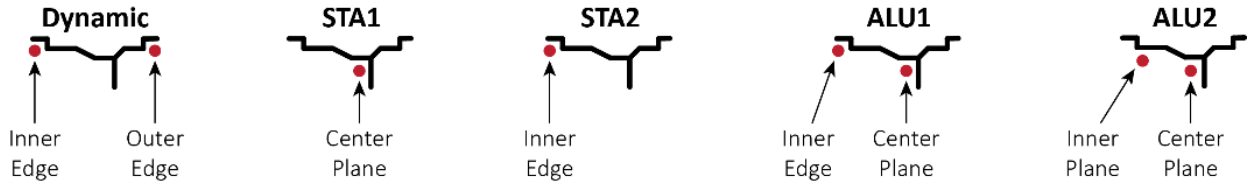

- **Start button.** Starts the Wheel spinning, if the Hood is down. By default, lowering the Hood starts the Wheel spinning. To disable this, press Stop and then press the R button. Press Stop and R again to re-enable.
- **Stop button.** Stops the Wheel from spinning.

**⚠ WARNING** In an emergency, the fastest way to stop the Wheel and the Shaft is to press the Stop button and press down on the Brake Pedal.

- **Distance, Width, and Diameter diagrams.** Located just above the Plus and Minus buttons, they are visual representations of how you measure the Wheel to get the necessary information:
  - *Distance.* Distance from the side of the Balancer to the Inner Edge of the Wheel.
  - *Width.* Width of the Wheel from the Inner Edge to the Outer Edge.
  - *Diameter.* Diameter of the Wheel at the Rim.

See [About Measurements](#) for more information.

- **Plus and Minus buttons.** Press to increase the value (Plus button) or lower the value (Minus button). One set for each column: Distance, Width, and Diameter.
- **F button.** Press to switch between Balancing Modes.
- **R button.** Used with Stop button to toggle Auto Hood Start.
- **<5g button.** By default, the Balancer shows values for Weight needed rounded to .25 ounce / 7 grams. If you want to see Weight values at a more granular level, press and *hold* **<5g**.

Weight values are shown **not** rounded off while you press and hold **<5g**.

For example:



## About Measurements

In order to balance a Wheel, the Balancer **must** know three pieces of information about the Wheel. You must gather these measurements and enter them manually for every Wheel you balance.

The three measurements are:

- **Distance.** The distance from the side of the Balancer to the Inner Edge of the Wheel. Measured by the Inner Arm. To measure and input the value, pull out the Inner Arm and touch it to the Inner Edge of the Wheel, note the value on the Ruler on the Inner Arm, and enter that value using the **+** and **-** buttons under **Distance** on the Control Panel.
- **Width.** The distance from the Inner Edge of the Wheel to the Outer Edge. Determined manually by measuring with the Caliper. To measure and input the value, measure with the Calipers, then enter that value using the **+** and **-** buttons under **Width** on the Control Panel.
- **Diameter.** The distance from Outer Edge to Outer Edge. Should be printed on the sidewall of the Tire. Can also be determined manually by measuring with the Caliper. To measure and input the value, read the value from the Tire Sidewall or measure with the Calipers, then enter that value using the **+** and **-** buttons under **Diameter** on the Control Panel.

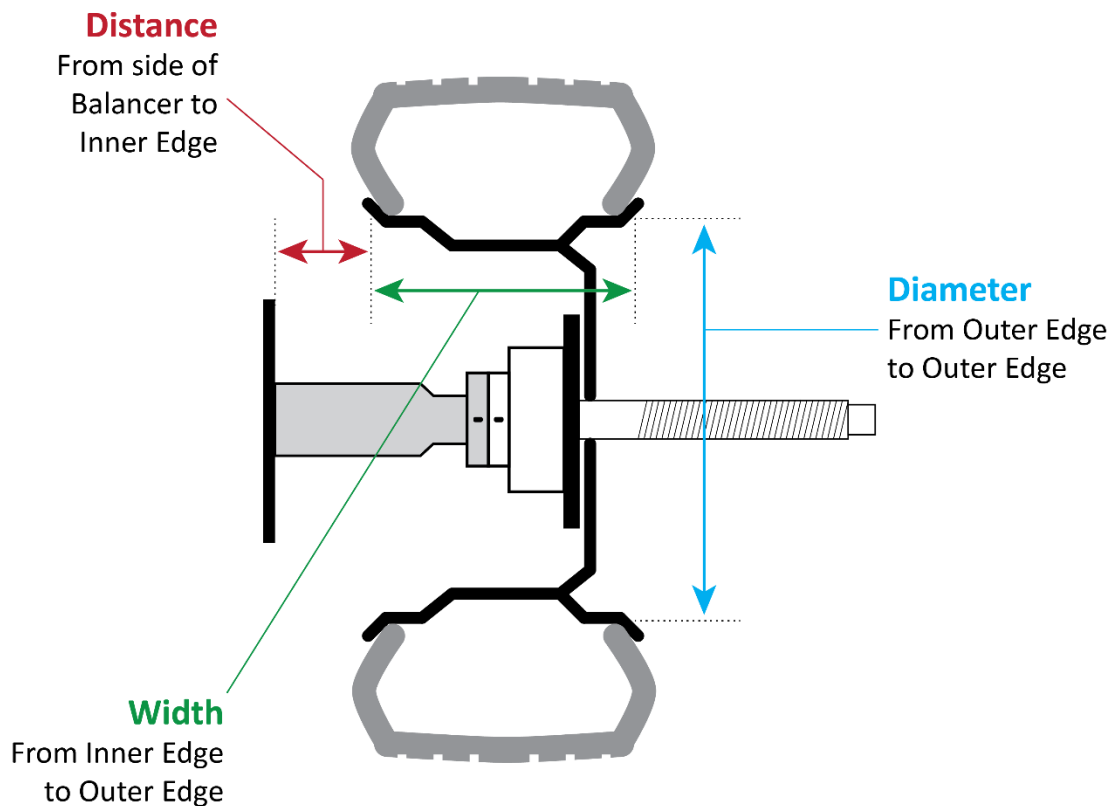

**Note:** If you start balancing a Wheel without entering one or more measurements, the Balancer will use default values for any measurement you did not enter. So the Balancer will spin and weight to be added will appear, but without correct measurements it is virtually guaranteed that the balance will **not** be accurate.



## Mounting a Wheel

When you want to balance a Wheel, the first step is to mount it on the Shaft.

**Important:** All Wheels should be mounted so that the inside (the side of the Wheel that goes closest to the Vehicle) goes on the Shaft first.

There are three ways to mount a Wheel onto the Shaft:

- **Front-Cone Mounting.** The preferred method, as it generally produces the most accurate balancing results.

An appropriately sized Mounting Cone goes on after the Wheel, then the Quick Nut.

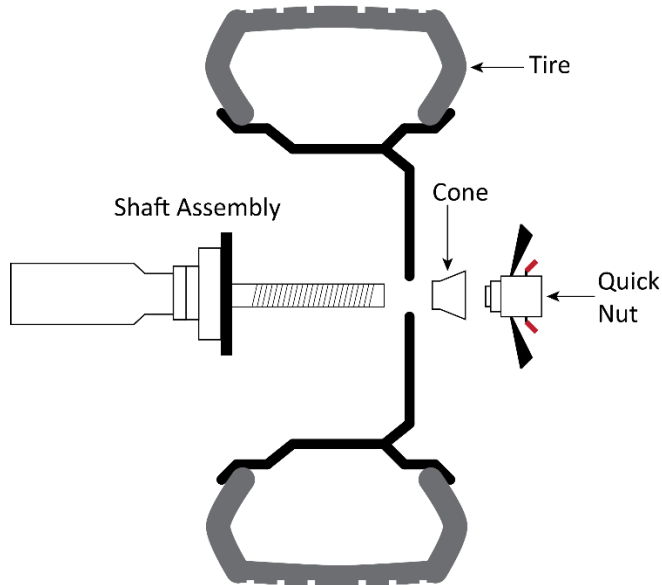

- **Rear-Cone Mounting.** Use this method if the Wheel you are balancing cannot be mounted with Front-Cone Mounting.

The Spring goes on first, then an appropriately sized Cone, the Wheel, the Quick Nut Cap, and finally the Quick Nut.

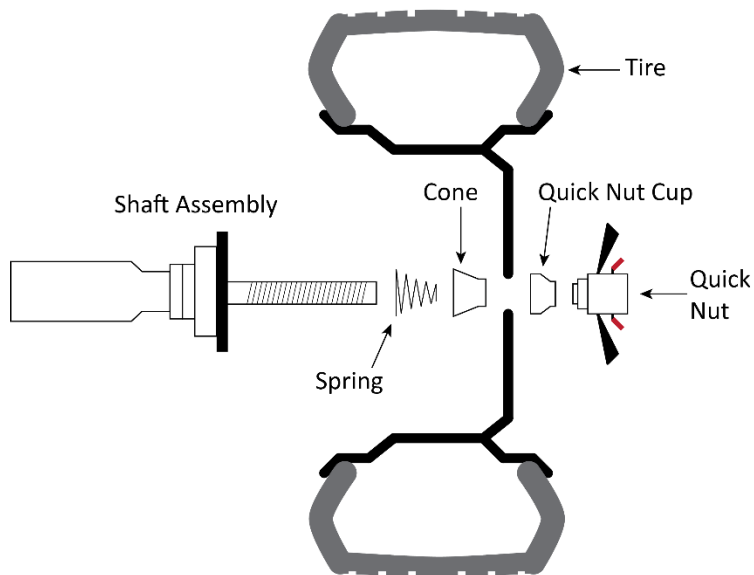

- **Dual-Cone Mounting.** Generally used only for some aftermarket or OEM performance Wheels that have a center hole that is deep enough to allow the use of two cones on the Shaft.

The Spring goes on first, then an appropriately sized Cone, the Wheel, a second appropriately sized Cone, and finally the Quick Nut.

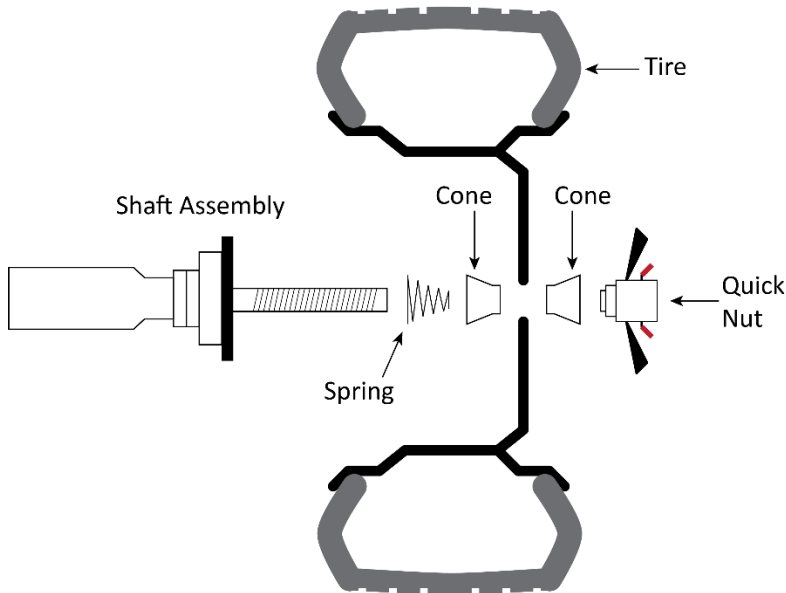

### To mount a Wheel:

1. Make sure you are dressed appropriately: leather gloves, steel-toed work boots, back belts, hearing protection, and ANSI-approved eye protection: safety glasses, face shield, or goggles.
2. Determine which mounting method you want to use.
3. Move the Wheel you are going to mount next to the Shaft.
4. Select the Mounting Cone that best fits the center hole of the Wheel.
5. If Rear-Cone or Dual-Cone Mounting, put the Spring and the desired Cone onto the Shaft.
6. Lift the Wheel and put it onto the Shaft, then slide it back towards the Shaft Flange.

You may need to lift the Wheel slightly when positioning a Cone in the center hole of the Wheel.

7. While holding the Wheel and other hardware in place, slide the Quick Nut over the Shaft while holding the red Quick-Release Levers next to the black, larger Wings.

Holding the red Quick-Release Levers next to the Wings lets you quickly slide the Quick Nut into position near the Wheel.

8. Release the Quick-Release Levers.
9. Turn the Wings to fully tighten the Quick Nut, and thus the Wheel, in place.

You may want to spin the Wheel some as you tighten the Quick Nut; this can help you get a strong, secure fit.

**Important:** Do not hammer or hit the Quick Nut to tighten it. You will damage the Quick Nut, which is **not** covered under the Warranty.

## Dynamic Balancing

Dynamic Balancing balances a Wheel at the Inner and Outer Edges. It is generally used for steel Wheels.

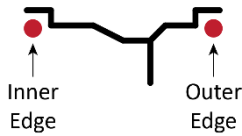

If weight is needed, Clip-On Weights are placed on the Inner and Outer Edges.

**Note:** In the following procedure, all of the examples use ounces and inches. The only exception is the distance measured by the Inner Arm, which is in Centimeters and cannot be changed (because the Ruler on the Inner Arm uses Centimeters).

### To Balance a Wheel using Dynamic Mode:

1. Make sure you are dressed appropriately: leather gloves, steel-toed work boots, back belts, hearing protection, and ANSI-approved eye protection: safety glasses, face shield, or goggles.
2. Visually inspect the Balancer to make sure everything is in place. The Hood should be **up**.  
If you find any issues, fix them. If there are issues you cannot fix, refer to **Troubleshooting**.
3. Make sure the Wheel you want to balance is both **clean** and free of any weights that may have been put on previously. If it is dirty, clean it. Remove any existing weights.
4. Mount the Wheel on the Balancer.

Refer to **Mounting a Wheel** for mounting instructions, if needed.

5. Turn the Balancer Off and then back On, to reset it.

On power up, **USA | 516** will appear in the Inner and Outer Windows, followed by default Wheel dimensions. (The “516” is the software version; this changes from time to time, so there’s no need to worry if the number is different on your Balancer.)

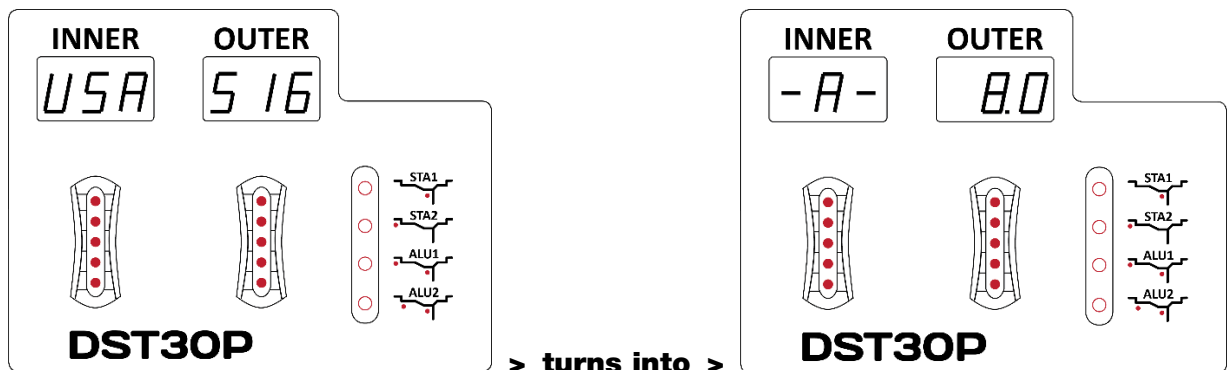

After a few seconds, the Inner and Outer Windows change to **-A- | 8.0**. (The -A- tells you to enter the Distance value; 8.0 is the default value for Distance).

6. Check the Indicators next to the four Balancing Modes shown on the Control Panel.  
Because we are doing a Dynamic Mode balance, all four of the Indicators need to be off.
7. If any of the indicators are on, press the **F** button until they are **all off**.

- Pull out the Inner Arm and place it against the Inner Edge.

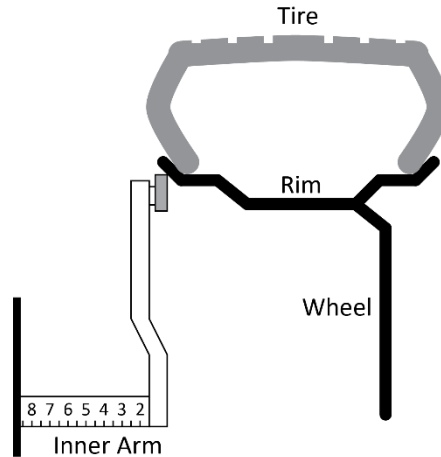

This tells the Balancer the distance from the edge of the Balancer to the edge of the Wheel being balanced.

- On the Inner Arm Ruler, note the distance from the Balancer to the Inner Edge; **8.5** in the drawing above.
- Return the Inner Arm to its normal location.
- Input the distance you noted on the Inner Arm Ruler using the **+** and **-** buttons under **Distance**.

The **8.0** is replaced by the value you enter. It goes up and down in small increments as you press the **+** and **-** buttons.

- When the Distance value is correct, use the Caliper to measure the width of the Rim, Inner Edge to Outer Edge.
- Input the distance you measured using the Calipers using the **+** and **-** buttons under Width.

When you press the **+** or **-** button under Width for the first time, the Inner Window changes from **-A-** to **-L-** and displays the default value of **5.7** in the Outer Window.



The value in the Outer Window changes as you press the **+** and **-** buttons under Width.

- When the Width value is correct, use the Calipers to measure the diameter of the Rim or read the diameter off the Sidewall of the Tire.
- Input the diameter using the **+** and **-** buttons under Diameter.

When you press the **+** or **-** button under Diameter for the first time, the Inner Window changes from **-L-** to **-d-** and displays the default value of **14.0** in the Outer Window.



The value in the Outer Window changes as you press the **+** and **-** buttons under Diameter.

When the Diameter value is correct, you are done inputting measurements.

17. Lower the Hood; the Wheel spins briefly.

18. When the Wheel stops, lift the Hood.

19. Check the value on the Inner Window.

- If the value is **00**, you do not need to add Weight to the Inner Edge of the Wheel.
- If there is a value—**.25**, for example—you need to add that amount of Weight to the Inner Edge of the Wheel.

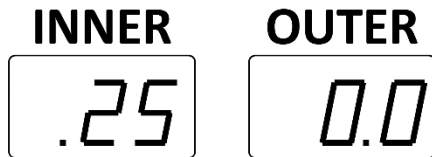

20. To add Weight to the Inner Edge, find a Clip-On Weight of the correct amount and the Wheel Weight Tool.

21. Turn the Wheel, watching the Indicators under the Inner Window.

The Indicators light up or go out as you move the Wheel.

22. When all of the Indicators go on, press the Brake Pedal to hold the Wheel at that position.

23. Add the Clip-On Weight at Top Dead Center on the Wheel (12 o'clock high) on the Inner Edge.

24. Release the Brake Pedal.

25. Check the value on the Outer Window:

- If the value is **00**, you do not need to add Weight to the Outer Edge of the Wheel.
- If there is a value—**.25**, for example—you need to add that amount of Weight to the Outer Edge of the Wheel.

26. To add Weight to the Outer Edge, find a Clip-On Weight of the correct amount and the Wheel Weight Tool.

27. Turn the Wheel, watching the Indicators under the Outer Window.

The Indicators light up or go out as you move the Wheel.

28. When all of the Indicators go on, press the Brake Pedal to hold the Wheel at that position.

29. Add the Clip-On Weight at Top Dead Center on the Wheel (12 o'clock high) on the Outer Edge.

30. Release the Brake Pedal.

31. Lower the Hood to spin the Wheel again.

The Wheel is balanced when both the Inner and Outer Windows show **00**.

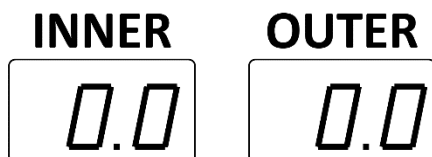

It may take more than one time adding weights to get to **0.0 | 0.0**.

---

## Static Balancing

Static Balancing is for older Wheels under 4 inches wide and motorcycle Wheels. If the Wheel is out of balance, Weight goes in one location only.

The Balancer supports two Static Balancing Modes:

- **STA1**. If the Wheel is out of balance, Weight goes on the Center Plane.

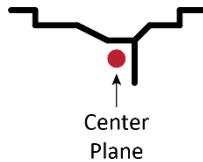

- **STA2**. If the Wheel is out of balance, Weight goes on the Inner Edge.

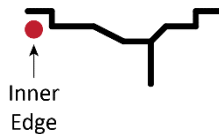

### To Balance a Wheel using STA1 or STA2:

1. Make sure you are dressed appropriately: leather gloves, steel-toed work boots, back belts, hearing protection, and ANSI-approved eye protection: safety glasses, face shield, or goggles.
2. Visually inspect the Balancer to make sure everything is in place. The Hood should be **up**.
3. Make sure the Wheel you want to balance is both clean and free of any weights that may have been put on previously. If it is dirty, clean it. Remove any existing weights.
4. Mount the Wheel on the Balancer.
5. Turn the Balancer Off and then back On, to reset it.

On power up, **USA | 516** will appear in the Inner and Outer Windows, followed by default Wheel dimensions. (The "516" is the software version; this changes from time to time, so there's no need to worry if the number is different on your Balancer.)

6. After a few seconds, the Inner and Outer Windows change to **-A- | 8.0**. (8.0 is the default value for Distance).
7. On the Control Panel, press the **F** button until either the **STA1** or the **STA2** indicator is lit, depending on which Static Mode you want to use.
8. Pull out the Inner Arm and place it on the Inner Edge.

This tells the Balancer the distance from the edge of the Balancer to the edge of the Wheel being balanced.

9. On the Inner Arm Ruler, note the distance from the Balancer to the Inner Edge.
10. Return the Inner Arm to its normal location.
11. Input the distance you noted on the Inner Arm Ruler using the **+** and **-** buttons under **Distance**.

The **8.0** is replaced by the value you enter. It goes up and down in small increments as you press the **+** and **-** buttons.

12. When the Distance value is correct, use the Caliper to measure the width of the Rim, Inner Edge to Outer Edge.
13. Input the distance you measured using the Calipers using the **+** and **-** buttons under Width.



When you press the **+** or **-** button under Width for the first time, the Inner Window changes from **-A-** to **-L-** and displays the value **5.7** in the Outer Window.



The value in the Outer Window changes as you press the **+** and **-** buttons under Width.

14. When the Width value is correct, use the Calipers to measure the diameter of the Rim or read the diameter off the Sidewall of the Tire.

15. Input the diameter using the **+** and **-** buttons under Diameter.

When you press the **+** or **-** button under Diameter for the first time, the Inner Window changes from **-L-** to **-d-** and displays the value **14.0** in the Outer Window.



The value in the Outer Window changes as you press the **+** and **-** buttons under Diameter.

When the Diameter value is correct, you are done inputting measurements.

16. Lower the Hood; the Wheel spins briefly.

17. When the Wheel stops, lift the Hood.

The Inner Window shows the amount of Weight you need to add to the Center Plane for **STA1** or the Inner Edge for **STA2**.

The Outer Window shows the selected Balancing Mode, **St.1** or **St.2**.

If the Inner window shows **00**, the Wheel is balanced; no Weight needs to be added.

18. To add Weight, turn the Wheel, watching the indicators under the Inner Window.

The Indicators light up or go out as you move the Wheel.

19. When all of the Indicators go on, press the Brake Pedal to hold the Wheel at that position.

20. Add the Weight at Top Dead Center on the Wheel (12 o'clock high) at the appropriate location.

For **STA1**, add Weight to the Center Plane.

For **STA2**, add Weight to the Inner Edge.

21. When the Weight is added, release the Brake Pedal.

22. Lower the Hood to spin the Wheel again.

The Wheel is balanced when both the Inner Window shows **00**.

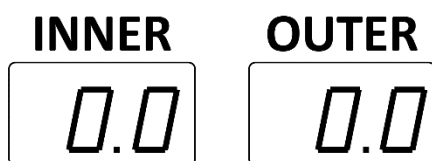

It may take more than one time adding weights to get to **0.0 | 0.0**.

---

## Aluminum Alloy Balancing

ALU Modes are for balancing Aluminum Alloy Wheels using Adhesive Weight.

The Balancer supports two ALU Modes:

- **ALU1.** If the Wheel is out of balance, Weight goes on the Inner Edge and/or the Center Plane.

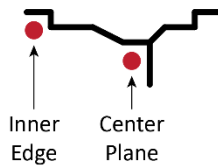

- **ALU2.** If the Wheel is out of balance, Weight goes on the Inner Plane and/or the Center Plane.

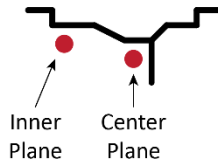

### To balance a Wheel using ALU1 or ALU2:

1. Make sure you are dressed appropriately: leather gloves, steel-toed work boots, back belts, hearing protection, and ANSI-approved eye protection: safety glasses, face shield, or goggles.

2. Visually inspect the Balancer to make sure everything is in place. The Hood should be **up**.

If you find any issues, fix them. If there are issues you cannot fix, refer to [Troubleshooting](#).

3. Make sure the Wheel you want to balance is both clean and free of any weights that may have been put on previously. If it is dirty, clean it. Remove any existing weights.



#### Tip

When using Adhesive Weight, it is extremely important to **clean the Wheel**, the cleaner the Wheel, the longer the Adhesive Weight stays in place.

4. Mount the Wheel on the Balancer.

Refer to [Mounting a Wheel](#) for mounting instructions, if needed.

5. Turn the Balancer Off and then back On, to reset it.

On power up, **USA | 516** will appear in the Inner and Outer Windows, followed by default Wheel dimensions. (The “516” is the software version; this changes from time to time, so there’s no need to worry if the number is different on your Balancer.)

6. After a few seconds, the Inner and Outer Windows change to **-A- | 8.0**. (8.0 is the default value for Distance).

7. On the Control Panel, press the **F** button until either the **ALU1** or the **ALU2** Indicator is lit, depending on which Aluminum Alloy Mode you want to use.

8. Pull out the Inner Arm and place it against the Inner Edge of the Wheel being balanced.

This tells the Balancer the distance from the edge of the Balancer to the edge of the Wheel being balanced.

9. On the Inner Arm Ruler, note the distance from the Balancer to the Inner Edge.

10. Return the Inner Arm to its normal location.

11. Input the distance you noted on the Inner Arm Ruler using the **+** and **-** buttons under **Distance**.

The **8.0** is replaced by the value you enter. It goes up and down in small increments as you press the buttons.

12. When the Distance value is correct, use the Caliper to measure the width of the Rim, Inner Edge to Outer Edge.

13. Input the distance you measured using the Calipers using the **+** and **-** buttons under Width.

When you press the **+** or **-** button under Width for the first time, the Inner Window changes from **-A-** to **-L-** and displays the value **5.7** in the Outer Window.



The value in the Outer Window changes as you press the **+** and **-** buttons under Width.

14. When the Width value is correct, use the Calipers to measure the diameter of the Rim or read the diameter off the Sidewall of the Tire.

15. Input the diameter of the Wheel using the **+** and **-** buttons under Diameter.

When you press the **+** or **-** button under Diameter for the first time, the Inner Window changes from **-L-** to **-d-** and displays the value **14.0** in the Outer Window.



The value in the Outer Window changes as you press the **+** and **-** buttons under Diameter.

When the Diameter value is correct, you are done inputting measurements.

16. Lower the Hood; the Wheel spins briefly.

17. When the Wheel stops, lift the Hood.

18. Check the value on the Inner Window.

- If the value is **00**, you do not need to add weight to the Inner Edge or the Inner Plane.
- If there is a value—**.25**, for example—you need to add that amount of Weight to the Inner Edge or the Inner Plane.

19. To add Weight, break off the appropriate number of Adhesive Weight sections.

20. Turn the Wheel, watching the indicators under the Inner Window.

The Indicators light up or go out as you move the Wheel.

21. When all of the Indicators go on, press the Brake Pedal to hold the Wheel at that position.

22. Pull the backing off the Adhesive Weights, then add the Weight at Top Dead Center on the Wheel (12 o'clock high) on the Inner Edge or the Inner Plane, as appropriate for the ALU Mode.

If you are adding Adhesive Weight with multiple sections, center them on Top Dead Center.

24. Check the value on the Outer Window:

- If the value is **00**, you do not need to add Weight to the Center Plane.
- If there is a value—**.25**, for example—you need to add that amount of Weight to the Center Plane (for both **ALU1** and **ALU2**).

25. To add Weight, break off the appropriate number of Adhesive Weight sections.

26. Turn the Wheel, watching the indicators under the Inner Window.

The Indicators light up or go out as you move the Wheel.

27. When all of the Indicators go on, press the Brake Pedal to hold the Wheel at that position.

28. Pull the backing off the Adhesive Weights, then add the Weight at Top Dead Center on the Wheel (12 o'clock high) on the Center Plane.

If you are adding Adhesive Weight with multiple sections, center them on Top Dead Center.

29. Release the Brake Pedal.

30. Lower the Hood to spin the Wheel again.

The Wheel is balanced when both the Inner and Outer Windows show **00**.

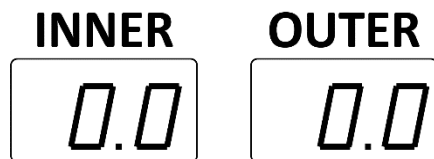

It may take more than one time adding weights to get to **0.0 | 0.0**.

## Switching Between Ounces and Grams

The display on the Inner and Outer Windows for how much weight is needed to balance a Wheel can show values in Ounces or Grams. The default is Ounces.

### To switch from the current setting to the other setting:

1. Run a balancing session.

You can use default values; having a Wheel on the Balancer is not required.

2. When the Wheel stops moving, press the **Stop** button and hold it down, then also press the **+** and **-** buttons under **Distance**.

You will hear a beep; the display has changed from the current setting to the other setting.

3. To tell which setting is active, look at the values in the Inner and Outer Windows:

- If the values have decimal points, Ounces are active.
- If the values **do not** have decimal points, Grams are active.

**Note:** The Ounces/Grams setting, whichever setting is active, is saved if you restart the Balancer.

---

## Switching Between Inches and Millimeters for Distance

You cannot do this.

Distance is **always** measured in Centimeters, because the Ruler on the Inner Arm uses Centimeters. This means you can always use the values you see on the ruler and never have to make a conversion.

## Switching Between Inches and Millimeters for Width

When you are entering measurements for a Wheel, you can have the values for Wheel Width display in either Inches or Millimeters. The default is Inches.

### To switch from Inches and Millimeters for Wheel Width measurements:

1. Turn the Balancer Off and then back On again using the On/Off Switch.  
This sets the Wheel Width display setting back to the default, Inches.
2. Specify a Distance value.
3. Press the **+** or **-** button under **Width**.  
**-L-** appears on the Inner Window and a value appears in the Outer Window.  
The value in the Outer Window does not matter if you are just changing the display setting.
4. Press and hold the **Stop** button, then press the **+** and **-** buttons under **Width**.  
You will hear a beep; the display changes from Inches to Millimeters.
5. To tell which setting is active, look at the values in the Inner and Outer Windows:
  - If the values have decimal points, Inches are active.
  - If the values **do not** have decimal points, Millimeters are active.

**Note:** The Inches/Millimeters setting for Wheel Width is **not** saved if you restart the Balancer. Instead, it resets to the default, Inches.

---

## Switching Inches and Millimeters for Diameter

When you are entering measurements for a Wheel, you can have the values for Wheel Diameter display in either Inches or Millimeters. The default is Inches.

### To switch from Inches and Millimeters for Wheel Width measurements:

1. Turn the Balancer Off and then back On again using the On/Off Switch.  
This sets the Wheel Diameter display setting back to the default, Inches.
2. Specify a Distance value and then a Width value.
3. Press the **+** or **-** button under **Diameter**.  
**-d-** appears on the Inner Window and a value appears in the Outer Window.  
The value in the Outer Window does not matter if you are just changing the setting.
4. Press and hold the **Stop** button, then press the **+** and **-** buttons under **Diameter**.  
You will hear a beep; the display changes from Inches to Millimeters.
5. To tell which setting is active, look at the values in the Inner and Outer Windows:
  - If the values have decimal points, Inches are active.
  - If the values **do not** have decimal points, Millimeters are active.

**Note:** The Inches/Millimeters setting for Wheel Diameter is **not** saved if you restart the Balancer. It resets to the default, Inches.

**Important:** You must know what measurement system is active when you are entering measurements. If you do not, you could enter a value in Inches when the Balancer is set to Millimeters, or vice versa.

## Toggling Auto Hood Start

By default, lowering the Hood starts a balancing session. This is a convenience feature, so you just have to lower the Hood not lower the Hood and then press Start.

**Important:** If the Hood is up, you cannot start a balancing session.

To disable Auto Hood Start if it is enabled, press Stop and then press the R button. You will hear a beep. The setting has been changed.

To enable Auto Hood Start if it is disabled, press Stop and then press the R button. You will hear a beep. The setting has been changed.

**Note:** The Auto Hood Start setting, whether enabled or disabled, is saved if you restart the Balancer.

---

# Maintenance

Make sure your Balancer is maintained on a regular basis.

 **DANGER** Disconnect the Balancer from power **before performing any maintenance** and take whatever steps are necessary to make sure the Balancer cannot be re-energized until Maintenance is over. Because the Balancer uses electricity, you could be electrocuted or even killed if the unit is powered back on during Maintenance. If your organization has Lockout/Tagout policies, make sure to implement them before beginning Maintenance.

## To maintain your Wheel Balancer:

- **Daily:** Make sure the unit is clean and dry; clean it after each use.
- **Weekly:** Make sure the Shaft Assembly is correctly oriented with the Shaft Housing and is securely tightened.
- **Monthly:** Make sure all Anchor Bolts are tightened and secure.
- **Monthly:** Check all components to make sure they are in good operating condition. If you find a component that is **not** working correctly, take the unit out of service and refer to **Troubleshooting** for more information.
- **Every three months:** Check the bolts on the components attached to the rear of the unit to make sure they are tight and secure.
- **Yearly:** Have an Electrician come out and check the electronic components.
- **Yearly:** Take the unit out of service, disconnect the Balancer from its power source, and then thoroughly check and clean all components.

 **WARNING** Do not operate your Balancer if you find issues; instead, take the unit out of service, then contact your dealer, visit [www.bendpak.com/support/](http://www.bendpak.com/support/), call **BendPak Ranger at (805) 933-9970**, or email [support@bendpak.com](mailto:support@bendpak.com).

# Troubleshooting

**⚠ DANGER** Disconnect the Power Cord from power **before performing any troubleshooting procedures** and take whatever steps are necessary to make sure the unit cannot be re-energized until Troubleshooting is over. Because the unit uses electricity, you could be electrocuted or even killed if the unit is powered back on during a Troubleshooting procedure. If your organization has Lockout/Tagout policies, make sure to implement them before beginning any Troubleshooting.

Perform the following checks if you are experiencing balancing problems:

- Confirm the location and alignment of the alignment marks on the Shaft Assembly and Shaft Housing (see **Installing the Shaft** for more information).
- Make sure the Balancer is anchored (see **Anchoring the Balancer** for more information).
- Perform a Weight Location Verification Test (see **Weight Location Verification Test** for more information).

Perform the calibration with a steel Wheel of the most commonly used size.

**Note:** It is a good practice to keep a known good Wheel of the most commonly used size to use as a calibration / reference tire to assist in troubleshooting.

Make sure the calibration weight used is a 100 gram or 3.5 ounce weight and that is mounted correctly during the calibration procedure.

## Issues

Issue	Action to Take
Nothing on the Display Panel.	Make sure the Balancer is turned on and getting power.
The Balancer is not producing good balances on a consistent basis.	Perform a Dual-Plane Self-Calibration Procedure. Refer to <b>Dual-Plane Self-Calibration Procedure</b> for more information. Perform a Weight Location Verification Test. Refer to <b>Weight Location Verification Test</b> for more information.
Vibration persists after balancing.	A weight has come off; replace it. Tire is slipping on the Wheel (possible Tire Changer issue); have Tire remounted and then rebalanced. Stones or other objects caught in Tire tread; remove the objects, rebalance if necessary.

If you continue to have problems with your Wheel Balancer, visit [www.bendpak.com/support/](http://www.bendpak.com/support/), call **BendPak Ranger at (805) 933-9970**, or email [support@bendpak.com](mailto:support@bendpak.com).



---

## Dual-Plane Self-Calibration Procedure

The Dual-Plane Self-Calibration Procedure ensures the Balancer is producing accurate readings by aligning the software with the existing spindle positions and hardware on the Balancer.

Before performing the Dual-Plane Self-Calibration Procedure, make sure the Balancer is anchored to the floor and that the shaft and centering cones are clean and undamaged. Dirt or damage can cause inaccurate readings.

**Important:** Pay close attention to this procedure. If not done correctly, the Balancer will not produce accurate readings, leading to Wheels not being balanced correctly.

You will need a steel Wheel with a Tire of a commonly balanced size for this procedure. The Wheel must already be fully balanced.

### To perform the Dual-Plane Self-Calibration Procedure:

1. Mount an already balanced Wheel on the Balancer.
2. Enter the correct Distance, Width, and Diameter values for the Wheel into the Balancer.
3. Press and hold **Start** and **R** until **CAL | CAL** appears on the Inner and Outer Windows and the Indicators under those windows stop flashing.
4. Lower the Hood to start a balancing session.

The Wheel spins briefly, then stops.

**3.50** appears in the Inner Window (**100** if grams are selected) and **Add** appears in the Outer Window.

5. Turn the Wheel by hand until the Indicators under the Inner Window are all lit.
6. Add a 3.5 ounce /100 gram Calibration Weight (it's a Clip-On Weight) to the Inner Edge of the Wheel at Top Dead Center (12 o'clock high).
7. Close the Hood to start a balancing session.

The Wheel spins briefly, then stops.

**Add** appears in the Inner Window and **3.50** appears in the Outer Window (**100** if grams are selected) and.

8. Turn the Wheel by hand until the Indicators under the Outer Window are all lit.
9. Remove the Calibration Weight from the Inner Edge of the Wheel and add it to the Outer Edge at Top Dead Center (12 o'clock high).
10. Close the Hood to start a balancing session.

The Wheel spins briefly, then stops.

**End** appears on the Inner Window and **CAL** appears on the Outer Window.

11. Remove the Calibration Weight from the Wheel.

The Dual-Plane Self-Calibration Procedure is complete.

**Important:** If the Dual-Plane Self-Calibration Procedure does not complete successfully, visit [www.bendpak.com/support/](http://www.bendpak.com/support/), call **BendPak Ranger at (805) 933-9970**, or email [support@bendpak.com](mailto:support@bendpak.com) for assistance.

---

## Weight Location Verification Test

The Weight Location Verification Test verifies that the Balancer is calibrated correctly.

Before performing the Weight Location Verification Test, make sure the Balancer is bolted down to the floor and that the Shaft and Centering Cones are clean and undamaged. Even the slightest amount of dirt or damage can cause inaccurate readings.

**Important:** Pay close attention to this procedure. If not done correctly, the Balancer will not produce accurate readings, leading to Wheels not being balanced correctly.

You will need a steel Wheel with a Tire of a commonly balanced size for this procedure. The Wheel must already be fully balanced.

### To perform the Weight Location Verification Test:

1. Mount the already balanced Wheel on the Balancer.
2. Make sure Dynamic Mode is selected; no Balancing Modes should have their Indicator lit.
3. Enter the correct Distance, Width, and Diameter values for the Wheel into the Balancer.
4. Add a 3.5 ounce /100 gram Calibration Weight (it's a Clip-On Weight) to the Outer Edge of the Wheel at Top Dead Center (12 o'clock high).
5. Lower the Hood or press the Start button to start a balancing session.

The Wheel spins briefly, then stops.

**00** appears on the Inner Window and **3.5** on the Outer Window (**100** if grams is selected).

6. Turn the Wheel by hand until the Outer Indicators are all lit.

The Calibration Weight should be at Bottom Dead Center (6 o'clock low).

7. Remove the Calibration Weight from the Outer Edge of the Wheel.

8. Add the Calibration Weight to the Inner Edge of the Wheel.

9. Close the Hood or press the Start button to start a balancing session.

The Wheel spins briefly, then stops.

10. **3.5** appears on the Inner Window (**100** if grams is selected) and **00** in the Outer Window.

11. Turn the Wheel by hand until the Inner Indicators are all lit.

The Calibration Weight should be at Bottom Dead Center (6 o'clock low).

The Weight Location Verification Test is complete.

**Important:** If the Calibration Weight is not at Bottom Dead Center for both Inner and Outer Edges or any different values appear in the Outer or Inner Windows, the Balancer is not calibrated correctly. Visit [www.bendpak.com/support/](http://www.bendpak.com/support/), call **BendPak Ranger at (805) 933-9970**, or email [support@bendpak.com](mailto:support@bendpak.com) for assistance.

# Wiring Information

The Balancer comes with a Power Cord with three exposed wires. The three exposed wires need to be hard-wired to the facility's power system **or** connected to a 220 VAC or 110 VAC Plug, which is then connected to an appropriate power outlet.

**⚠ DANGER** All electrical work, such as hard-wiring the Balancer to the facility's power system or attaching a Plug to a Power Cord, **must be done by a licensed, certified Electrician** in accordance with all applicable local electrical codes. Damage to the unit caused by improper electrical installation voids your warranty.

The Balancer comes with a Power Cord but **not a Plug**; you or your Electrician must supply one.

The colors of the three exposed wires coming out of the Back of the Balancer are Brown, Blue, and Green/Yellow, the European color code. Note that the Green/Yellow wire can *sometimes* appear almost all Green, with very little yellow.

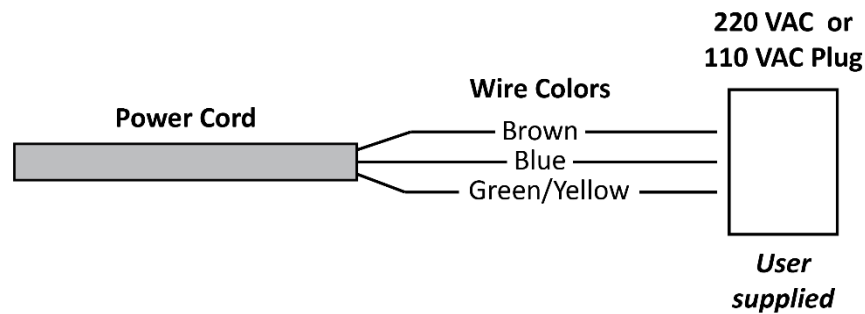

**Important:** To connect the three exposed wires to an appropriate Plug or to hard wire them to the facility's power system, have your Electrician follow all local electrical codes and the electrical codes for the country you are in.

If you are using the unit in the United States, the color codes on the wiring that comes with the Balancer correspond to:

- **Brown:** Live
- **Blue:** Live
- **Green/Yellow:** Ground

If you were using the unit in a European country, the color codes on the wiring that comes with the Balancer correspond to:

- **Brown:** Live
- **Blue:** Neutral
- **Green/Yellow:** Ground

Information about color code conventions in other regions and countries is available online. Make sure your Electrician installs the Plug or hard wires the Balancer in accordance with all applicable local electrical codes.

# Labels

**A**



**B**

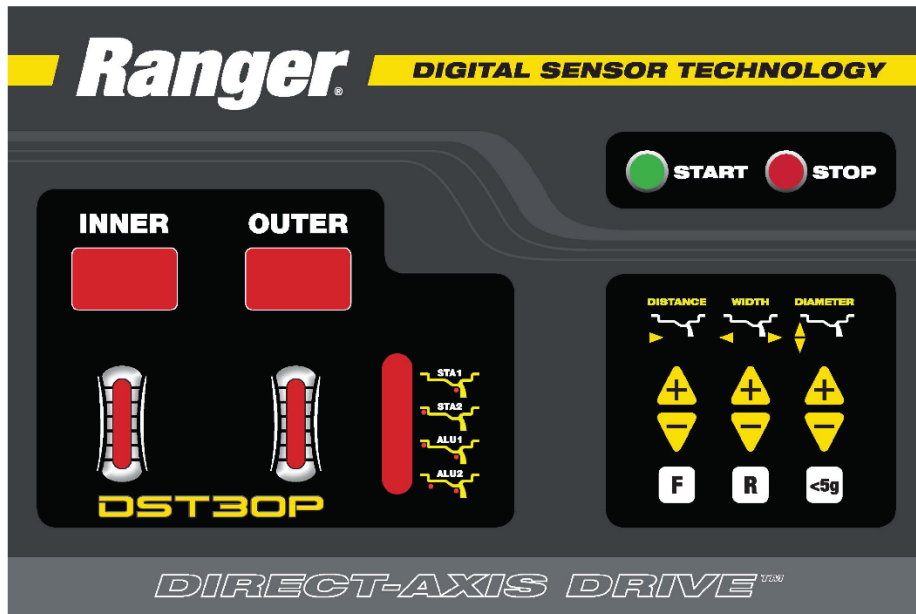

**C**

**IMPORTANT WEIGHT CALIBRATION INSTRUCTIONS**

This balancing machine is a precise instrument capable of registering the slightest rotational imbalance. When placing weights on wheels, (INCLUDING CALIBRATION WEIGHT), apply exactly perpendicular to the shaft at the **12 O'CLOCK POSITION**. Incorrect placement will result in additional weight call-outs and/or an improperly calibrated machine.

PN 5906597

**D**

**CAUTION**

**110/220V**

Select correct voltage or serious damage to the motor/electronics will result.

PN 5905280

**E**

**DANGER**

**GROUND ALL ELECTRICAL EQUIPMENT**

Establish and maintain proper earth ground. Voltage or ground hazard sufficient to cause shock, burn or death.

**CAUTION**

**THIS MACHINE HAS A DUAL VOLTAGE MOTOR.**

**BEFORE CONNECTING PLUG.** Confirm voltage selector switch on back of cabinet is positioned correctly, or serious damage to the motor/electronics will result.

PN 5906272



# Parts

## Main Cabinet

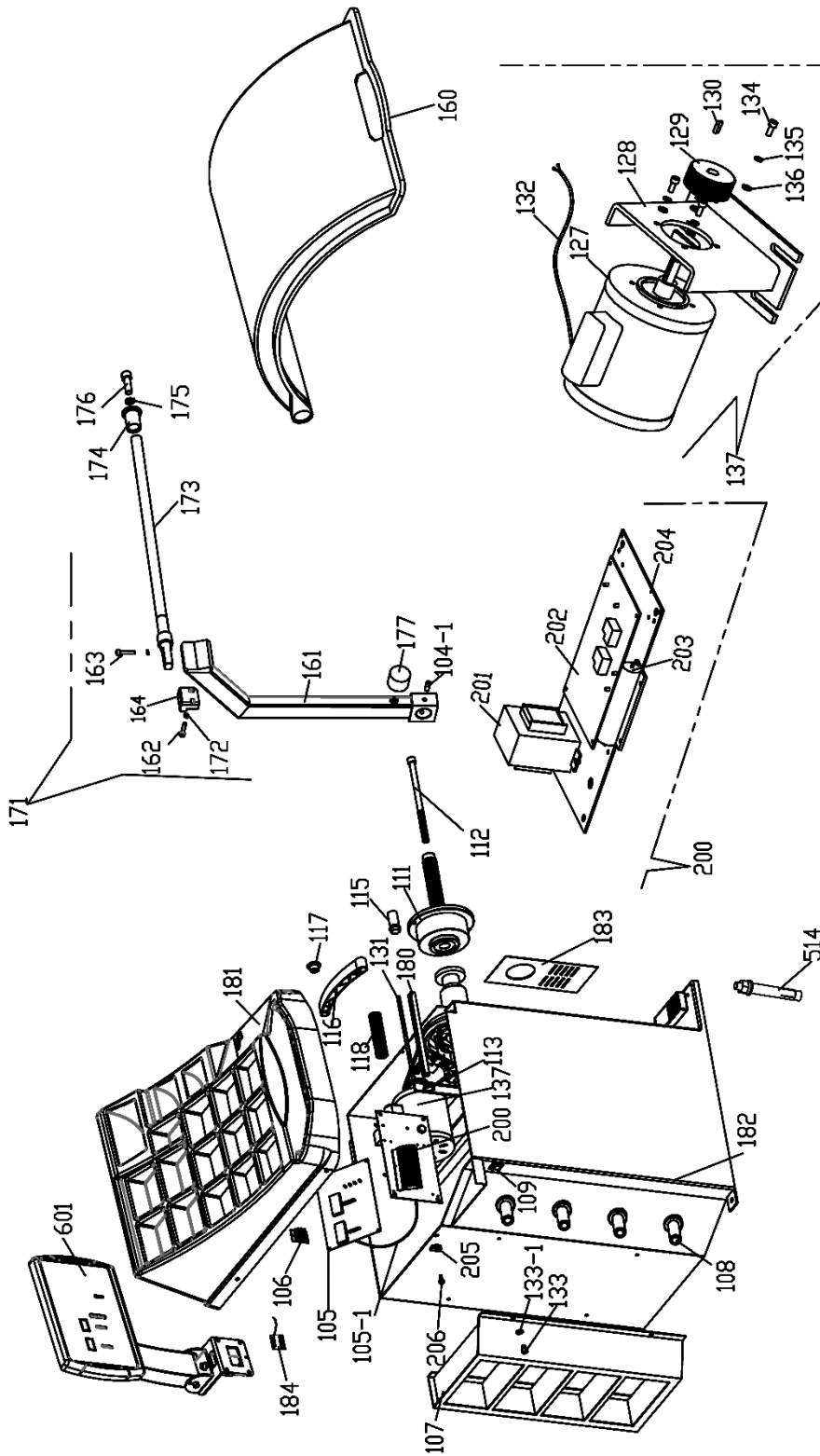

<b>BendPak #</b>	<b>ID Number</b>	<b>Description</b>
5327505	104-1	Hood Assembly Set Screw, M8 by 1.25 by 12
5328354	105	Computer Board
	105-1	Wires, Power To Computer Board
5327087	106	Voltage Selector Switch
5327993	107	Side Storage Rack
5327132	108	Cone Hanger
5525251	109	On/Off Switch
5327330	111	Thread Shaft/Spindle (36 mm)
5327182	112	SHCS, M14 by 240 mm
5327135	113	Distance Arm Small Sleeve
5327137	115	Distance Arm Large Sleeve
5327088	116	Distance Arm Handle
5327089	117	Distance Arm Pointer
5327138	118	Distance Arm Spring
5327092	127	Motor (110/220V 0.37 KW)
	128	Motor Bracket
5327144	129	Motor Pulley
5327145	130	Motor Pulley Key
5327591	131	Distance Arm Sticker
	132	110 V Power Cord
	133	Washer, $\Phi$ 8 flat
	133-1	HHB, M8 by 16
	134	SHCS, M6 by 16
	135	Washer, $\Phi$ 6 spring
	136	Washer, $\Phi$ 6 flat
	137	Motor Assembly
5328245	160	Injection Molded Hood
5328246	161	Injection Molded Hood Bracket
	162	SHCS. M6 by 25
	163	SHCS. M6 by 25
	164	Adjusting Plate
	171	Tire Guard Department
	172	Spring Pad, 6 mm

	173	Long Axis
	174	Front Axle Sleeve
	175	Spring Pad, 12 mm
	176	SHCS M12 by 35
	177	Stents Buffer Device
	180	Distance Arm Rod
	181	Weight Tray
	182	Chassis Body
	200	Power Board Assembly
5327146	201	Transformer
5327093	202	Power Board (220V)
5327147	203	Resistor
5327148	204	Electrical Mounting Plate
	205	B MODE Spring Spacer Nuts
	206	Cross Slot Screws
	206	Hexagon Socket Large Flat Head Screw
5327100	514	Anchor Bolt, 3/8 inch wide by 3.5 inch deep



# Hood Mounting Assembly

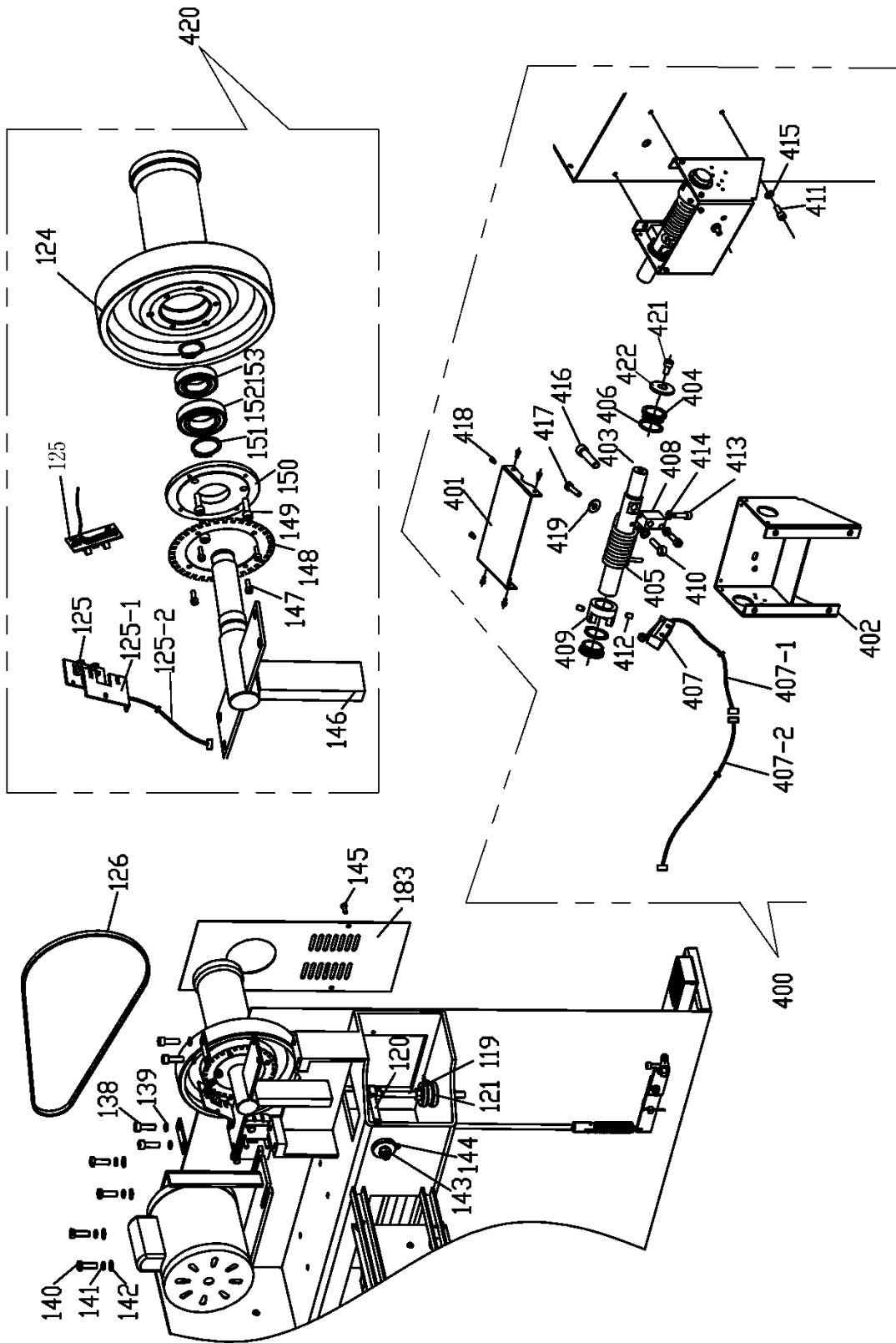

<b>BendPak #</b>	<b>ID Number</b>	<b>Description</b>
5327139	119	Pizo Vertical Shaft
5327140	120	Pizo Horizontal Shaft
5327141	121	Vertical Pizo Sensor
	124	Spindle Bushing Weldment
	125	Encoder Board
5327686	125-1	Encoder Board Bracket
	125-2	Wires, encode sensor to computer board
5327091	126	Motor Belt
	138	HHB M8 by 20
	139	Washer, 8 mm flat
	140	SHCS, M8 by 20
	141	Washer, 8 mm spring
	142	Washer, 8 mm wide flat
	143	Locknut, M10
	144	Pizo Sensor Pad
	145	Self Taping Screw, M4.8 by 16
	146	Deformation of Beams
	147	SHCS, M8 by 20
	148	Tootch, 32T
	149	SHCS, M8 by 20
	150	Bearing Cover
	151	Seeger Ring, 25 mm
	152	Bearing, 6006
	153	Bearing, 6005
	183	Chuck Guard
	184	Link Board for Wire
5327126	400	Hood Mounting Assembly
5327164	401	Hood Mounting Assembly Cover
5327165	402	Hood Mounting Assembly Bracket
5327166	403	Hood Rotating Shaft
5327167	404	Hood Shaft Bushing
5327168	405	Hood Spring
5327179	406	Snap Ring, 36 mm

5327169	407	Hood Switch
5327572	407-1	Short Hood Switch Wires
5327336	407-2	Long Hood Switch Wires
5327170	408	Hood Cam Stop
5327171	409	Hood Cam
5327180	410	Adjustable Eye Bolt, M8 by 1.25
5530304	411	HHB, M8 by 20
	412	Hexagon Socket Set Screw with flat point, M8 by 12
	413	SHCS, M8 by 25
	414	Hex Nut, M8
	415	Washer, 8 mm, flat
5327870	416	SHCS, M8 by 20
	417	HHB, M8 by 30
5327870	418	SHCS, M8 by 20
	419	Washer, 8 mm
5327143	420	Spindle with Position Board
	421	SHCS, M10 by 16
	422	Sensor Flat Mat

# Brake Assembly

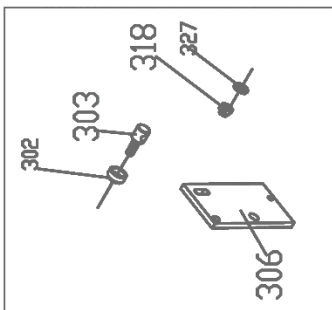
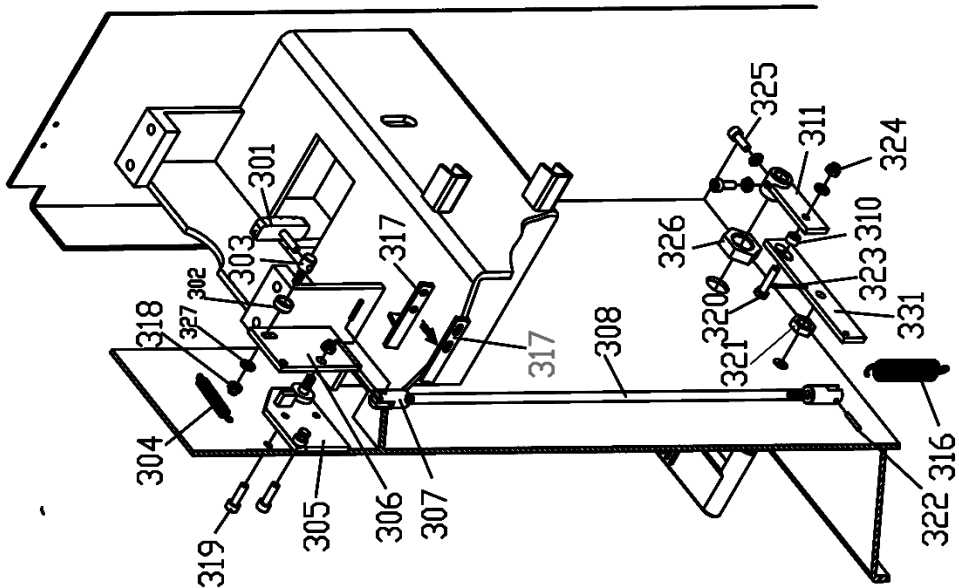
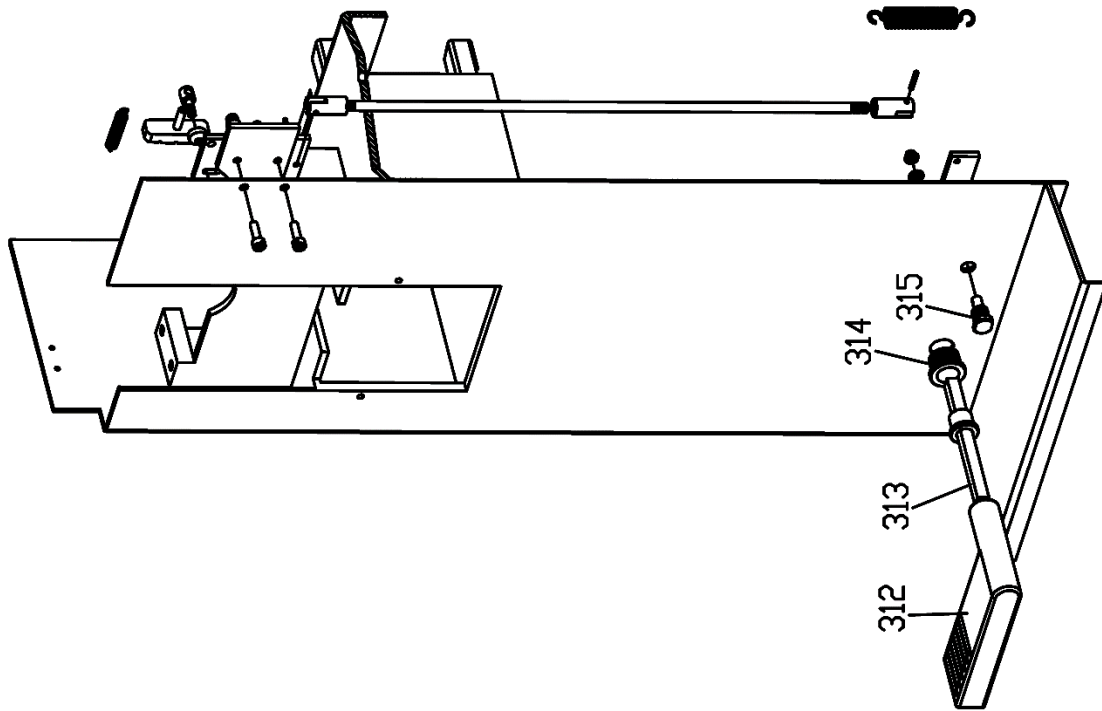

<b>BendPak #</b>	<b>ID Number</b>	<b>Description</b>
5327149	301	Brake Pad
5327150	302	Brake Pad Spacer
5327151	303	Brake Pad Bracket
5327152	304	Upper Brake Return Spring
5327153	305	Brake Fix Mounting Plate
5327154	306	Brake Movable Mounting Plate
5327155	307	Brake Rod Connector
5327156	308	Brake Rod
5327158	310	Brake Linkage Bushing
5327159	311	Small Brake Link
5327160	312	Brake Pedal
5327161	313	Brake Pedal Shaft
5327181	314	Pivot Screw
5327162	315	Brake Pedal Bushing
5327163	316	Lower Brake Return Spring
	317	Brake Bracket
	318	Lock Nut, M6
	319	SHCS, M6 by 12
	320	HHB, M6 by 25
	321	Nut, M12
	322	Pin, 4 by 16
	323	Cotter Pin, 2 by 20
	324	SHCS, M6 by 16
	325	Nut, M6
	326	Nut, M20
	327	Washer, $\Phi$ 6 flat
	327	Washer, $\Phi$ 8 flat
	331	Brake Warp

## Accessories

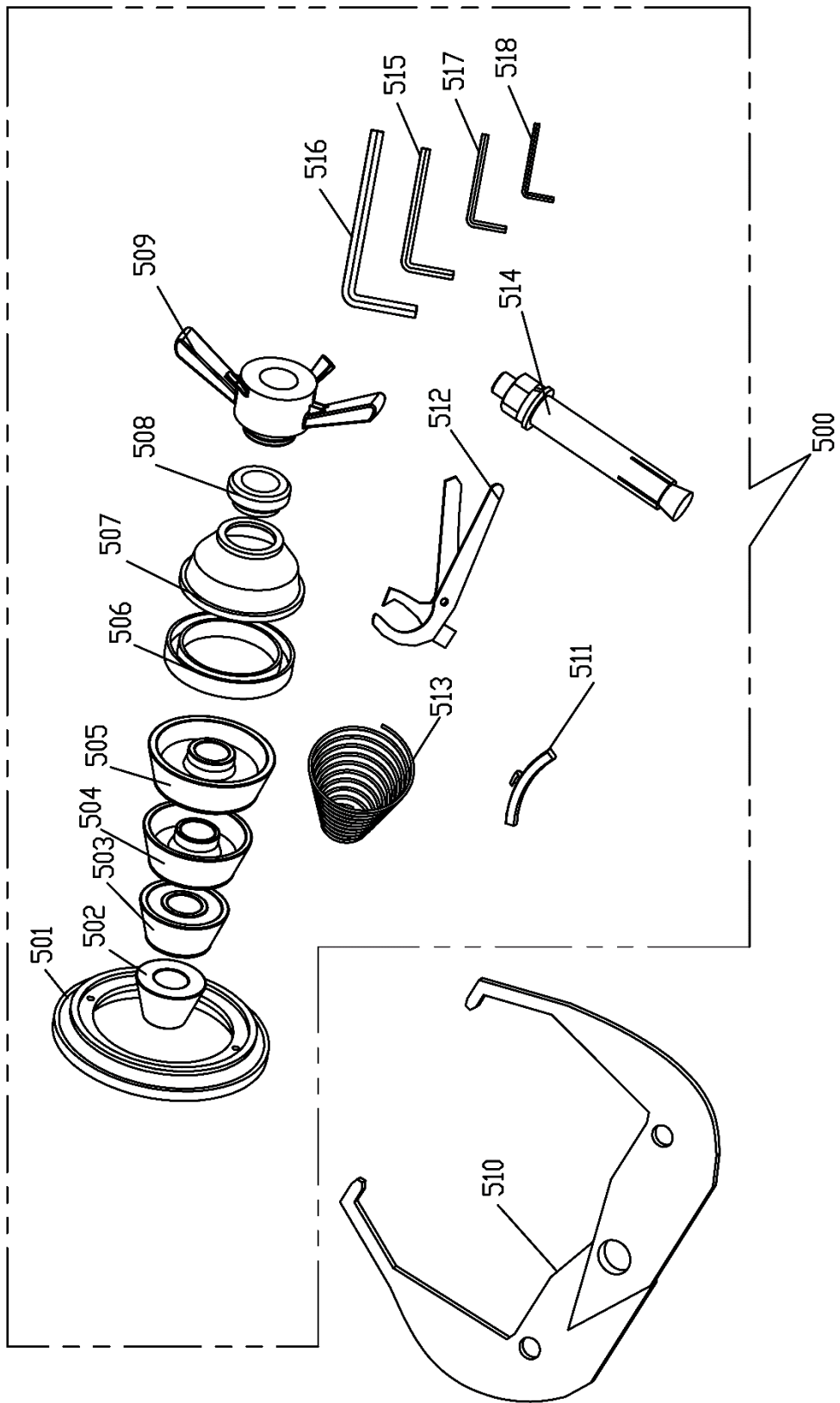

<b>BendPak #</b>	<b>ID Number</b>	<b>Description</b>
5327571	500	Accessory Box
5327063	501	Spacer Ring
5327069	502	44.5 – 74.5 mm Cone (36 mm)
5327071	503	69 – 94 mm Cone (36 mm)
5327067	504	90 – 115 mm Cone (36 mm)
5327065	505	110 – 134 mm Cone (36 mm)
5327074	506	Quick Nut Cup Cover
5327061	507	Quick Nut Cup
5327172	508	Quick Nut Cover
5327073	509	Quick Nut (36 mm)
5402187	510	Wheel Width Caliper
5346879	511	Calibration Weight (100 g)
5346425	512	Weight Pliers
5402252	513	Mounting Spring (36 mm)
5327100	514	Anchor Bolt, 3/8 inch wide by 3.5 inch deep
5328055	515	Hex Wrench, 6 mm
5327720	516	Hex Wrench, 12 mm
5328056	517	Hex Wrench, 4 mm
5328057	518	Allen Wrench, 3 mm

# Display Panel

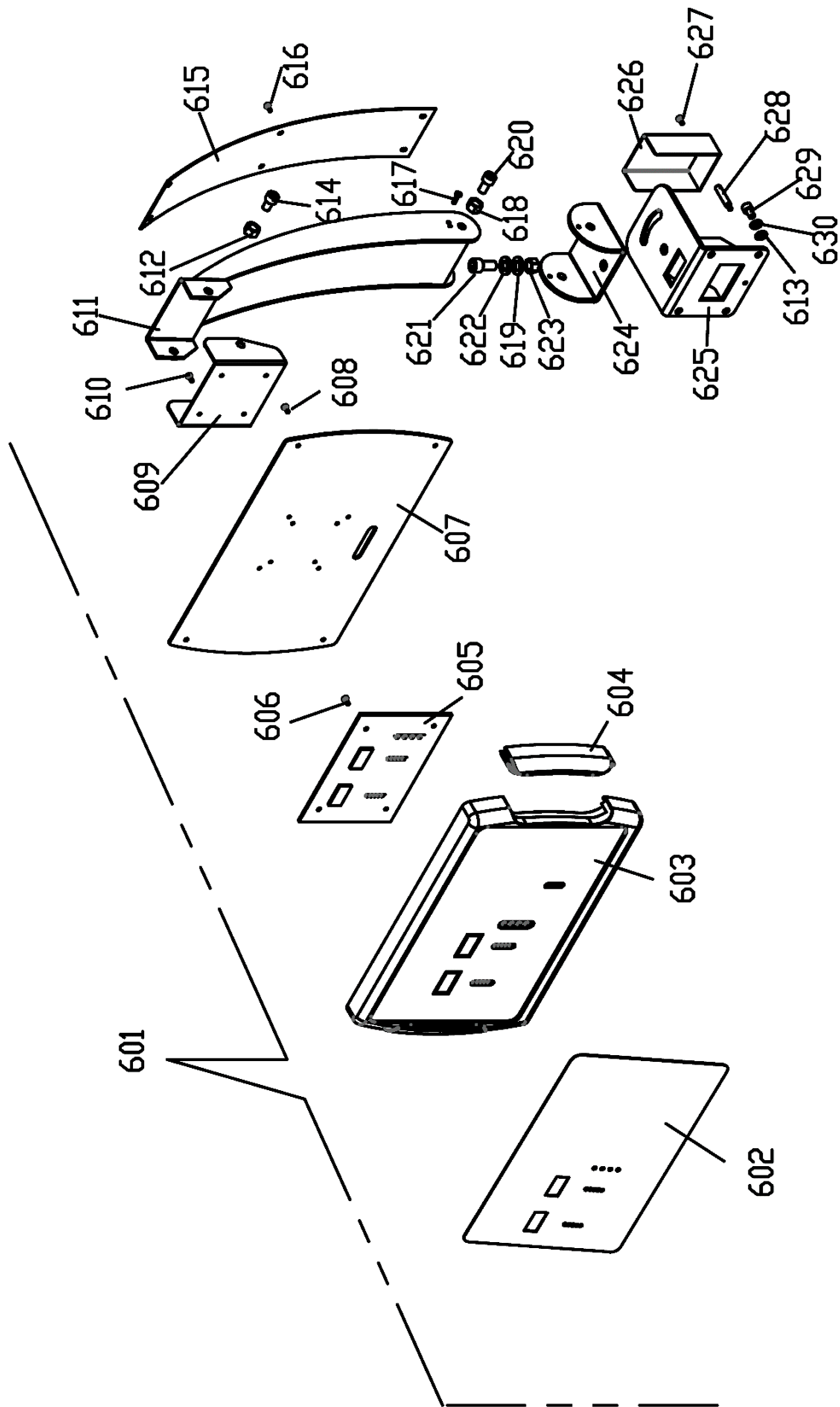



<b>BendPak #</b>	<b>ID Number</b>	<b>Description</b>
	601	Display Assembly
	602	Membrane Switch
	603	Display Mask
	604	Rubber, for display
	605	Computer Board
	606	Cross Recess Tapping Screw, ST 2.9 by 10
	607	Base Board
	608	SHCS, M4 by 8
	609	Display Link Board
	610	Cross Recess Screw, M4 by 16
	611	Support, installed and welded
	612	Nut M10
	613	Spacer, $\phi$ 8
	614	SHCS, M10 by 20
	615	Back Cover
	616	SHCS, M4 by 12
	617	SHCS, M4 by 20
	618	Nut, M10
	619	Spring spacer, $\phi$ 12
	620	SHCS, M10 by 20
	621	SHCS, M12 by 30
	622	Spacer, $\phi$ 12
	623	Nut M12
	624	Transposition
	625	Link Board, installed and welded
	626	Cover Piece, installed and welded
	627	SHCS, M4 by 12
	628	Fixed Block
	629	Spring Spacer, $\phi$ 8
	630	SHCS, M8 by 20







1645 Lemonwood Drive  
Santa Paula, CA 93060 USA