



58-GALLON AUXILIARY DIESEL TANK USER'S MANUAL

Part No. JDI-AFT58

FOR WARRANTY INFORMATION, PLEASE CALL 800-433-0708

DATE OF PURCHASE: _____

READ AND SAVE THIS MANUAL

FOR SERVICE ASSISTANCE, CALL 800-433-0708 OR VISIT JOHNDOW.COM



Important Safety Information

Read this manual and safety information before using this tank.

DANGER

DANGER indicates a hazardous situation which, if not avoided, will result in death or serious injury.

The use of this product includes the handling of diesel.

DANGER DIESEL

COMBUSTIBLE

HARMFUL OR FATAL IF SWALLOWED DO NOT USE THIS CONTAINER FOR DIESEL OR OTHER FLAMMABLE LIQUIDS

- Keep out of reach of children.
- Avoid prolonged breathing of vapors.
- Do not siphon by mouth.
- Do not store in vehicle or living space.
- Store and use in well-ventilated area.
- Do not use near heat, spark, or flame.
- Keep container closed.
- Do not smoke near or while using this product.

WARNING

WARNING indicates a hazardous situation which, if not avoided, could result in death or serious injury.

Static charge and container filling warnings.

- Dissipate any static electricity from your body by touching a metal surface away from the service station nozzle and prior to removing service station nozzle from dispensing pump.
- Keep service station nozzle in contact with tank while filling.
- Do not re-enter vehicle while filling. Re-entry can cause static buildup on person and create spark.
- Fill slowly to prevent buildup of static charge.
- Do not use electronics or mobile phones while using this product.
- Do not use funnels to fill or dispense fuel with this product.
- If fire starts, do not remove service station nozzle. Back away immediately.

WARNING

WARNING indicates a hazardous situation which, if not avoided, could result in death or serious injury.

Use, transportation, and storage warnings.

- Confirm all users are trained on safe working practices and comply with any and all regulations for using, transporting, and storing diesel.
- Confirm all fittings and connections are tight and leak-free.
- Do not modify this product or its components. Modifying this product in any way will void the warranty.
- Use only diesel in this tank to avoid possible damage to equipment.
- Perform the entire closure procedure after filling and before transporting.
- Do not place inside a vehicle trunk or inside passenger cabin.
- Do not store in direct sunlight.
- Avoid damage to the 12V transfer pump by:
 - only using a maximum of 30 minutes of continuous use in normal conditions
 - only use a maximum of 2 minutes in bypass mode
- Secure or strap tank to a trailer or truck bed with appropriate working load ratchet-style polyester cargo tie-down straps. Do not use nylon straps.
- The fill cap contains an internal check valve to relieve pressure inside the tank. Allow vapors to dissipate before using this tank.
- State and local regulations vary for the transportation of diesel. It is the vehicle operator's responsibility to review and comply with all federal, state, and local regulations regarding diesel transportation.
- It is the owner's/user's responsibility to review and comply with all building and fire codes regarding proper storage of diesel.

HAZARDOUS MATERIALS REGULATIONS (HMR)

The persons or functions using this product may be subject to additional regulations including PHM-SA, DOT 49 CFR Subchapter C – Hazardous Materials Regulations (HMR) as well as requirements of other federal agencies, and requirements of state and local government agencies. It is the persons responsibility to determine the applicability of these regulations and for compliance to these regulations.

Resources for additional information

<https://www.phmsa.dot.gov/regulations-and-compliance>

<https://www.phmsa.dot.gov/about-phmsa/phmsa-faqs>

CAPACITY AND DIMENSIONS

Product	JDI-AFT58		
Capacity (Gallons)	58	Length:	24"
Weight (Empty):	53 lbs.	Height:	26"
Width:	36"		

GETTING STARTED

If any parts are missing or damaged, contact JohnDow Industries for replacement.

CONTENTS

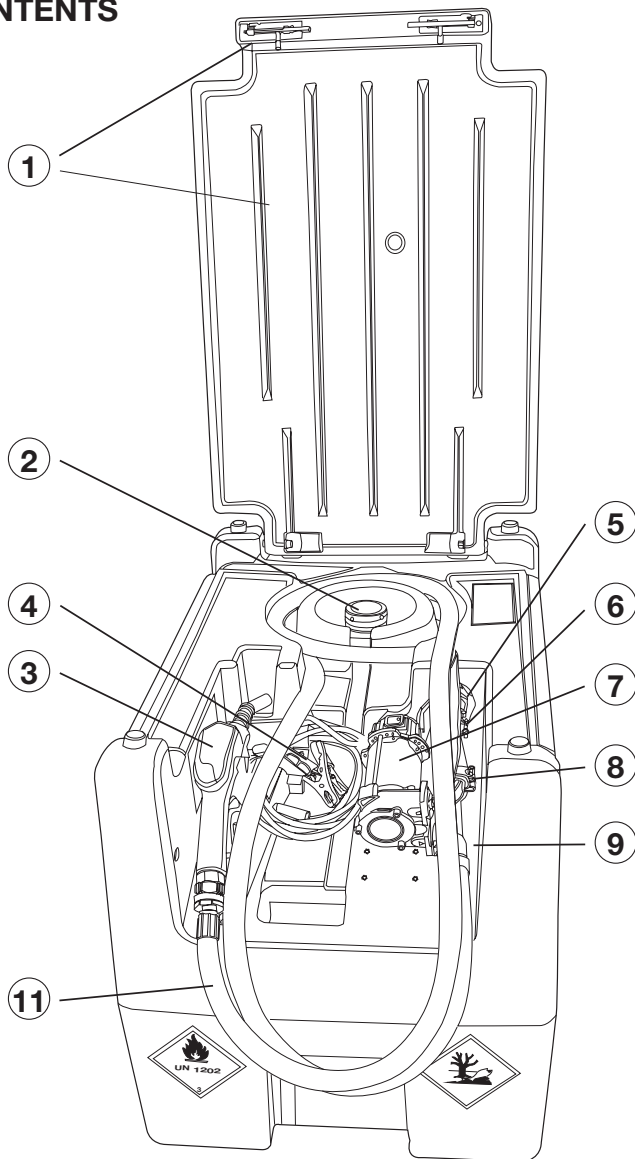

Item No.	Description
1	Locking Cover
2	Filler Cap with Vent
3	Automatic Dispensing Nozzle
4	Power Cable with Battery Terminal Clamps
5	Suction Hose Coupler with Filter
6	Ball Valve (Shut-off Valve)
7	12V Fuel Transfer Pump
8	Suction Hose, Clamp and Curved Tube
9	Threaded Joint
10	Lid Clasps
11	Delivery Hose

FOR SERVICE ASSISTANCE, CALL 800-433-0708 OR VISIT JOHNDOW.COM

OPERATION

Filling the Tank with Diesel Fuel

Before use, read and follow all safety instructions on page 2 of this user's manual.

1. Before filling, make sure the tank has no defects in the structure or equipment.
2. When filling the tank, maintain a minimum amount of empty space to allow for fuel expansion. Do not fill the tank beyond 95% of capacity (approximately 55 gallons).

Securing and Transporting Filled Tank

1. Properly secure the tank to a trailer or truck bed before transporting to avoid movement.
2. Use appropriate working load ratchet-style polyester cargo tie-down straps. Do not use Nylon straps.
3. DO NOT place the tank inside a trunk or passenger compartment.

FUEL TRANSFER

To Transfer Fuel from Tank

Before use, read and follow all safety instructions on page 2 of this user's manual.

1. Make sure the switch on the transfer pump is in the OFF ("O") position [7].
2. Unroll the transfer hose and insert the nozzle into the destination tank with nozzle locked in the OPEN position [12].
3. Connect the Power Cable Battery Terminal Clamps [4] to a battery terminal.
4. Turn the ball valve to the OPEN position [6].
5. Start the transfer pump by placing the switch in the ON ("I") position.
6. Proceed with the transfer for a maximum of 30 minutes from the time the pump was turned ON. DO NOT run pump when not transferring fuel for more than two minutes.
7. Fill the tank to the desired level or wait until the automatic nozzle snaps CLOSED [9].

Closure Process before Transporting:

1. Stop the transfer pump by placing the switch in the OFF ("O") position.
2. Turn the ball valve to the OFF position.
3. Relieve all residual pressure in the hose by dispensing fuel by holding the nozzle handle OPEN for a few seconds.
4. Roll-up the transfer hose and place the hose and nozzle in their proper position.
5. Disconnect the power cables from the battery terminals and store in the proper position.