



Artiglio 5000

Codice 4-122510 - 07/2017

Italiano	Manuale d'uso	3
English	Operator's manual	77
Français	Manuel d'utilisation	151
Deutsch	Betriebsanleitung	225
Español	Manual de uso	299

Copyrighted material. All rights reserved.
The information contained herein may be subject to modifications without prior notice.

Thank you for choosing our tyre changer

CORGHI

Dear Customer

Thank you for purchasing your Corghi Tyre Changer.

Your Tyre Changer has been designed to provide years of safe and dependable service, as long as it is used and maintained in accordance with the instructions provided in this manual.

Everyone who will use and/or perform maintenance on the tyre changer must read, understand and observe all the warnings and instructions provided in this manual, in addition to being properly trained.

This instruction manual must be considered an integral part of the tyre changer and kept together with it. However, no information contained in this manual and no device installed on the tyre changer can replace suitable training, correct operation and careful evaluation of procedures for working safely.

Always make sure that the tyre changer is in optimal operating conditions. If any malfunctions or probable situations of danger are observed, immediately stop the tyre changer and resolve the conditions before continuing.

For any question related to the correct tyre changer use or maintenance, contact your local official Corghi dealer.

Sincerely,
Corghi SpA

USER INFORMATION

User

Name _____

User

Address _____

Model

number _____

Serial

number _____

Date of

purchase _____

Date of

installation _____

Service and spare parts

manager _____

Phone

number _____

Sales

Representative _____

Phone

number _____



TRAINING CHECK

	Qualified	Rejected
<u>Safety Precautions</u>		
Warning and caution labels	<input type="checkbox"/>	<input type="checkbox"/>
High risk areas and other potential hazards	<input type="checkbox"/>	<input type="checkbox"/>
Operative safety procedures	<input type="checkbox"/>	<input type="checkbox"/>
<u>Maintenance and Performance Checks</u>		
Head mounting inspection	<input type="checkbox"/>	<input type="checkbox"/>
Adjustment and lubrication	<input type="checkbox"/>	<input type="checkbox"/>
Maintenance and instruction messages	<input type="checkbox"/>	<input type="checkbox"/>
<u>Clamping</u>		
Steel/alloy rims	<input type="checkbox"/>	<input type="checkbox"/>
Reverse rims	<input type="checkbox"/>	<input type="checkbox"/>
Closed rims	<input type="checkbox"/>	<input type="checkbox"/>
<u>Bead Breaking</u>		
Standard wheels	<input type="checkbox"/>	<input type="checkbox"/>
Low profile wheels	<input type="checkbox"/>	<input type="checkbox"/>
<u>Demounting procedure</u>		
Bead lubrication when removing the low profile tyres	<input type="checkbox"/>	<input type="checkbox"/>
Reverse rims	<input type="checkbox"/>	<input type="checkbox"/>
<u>Mounting</u>		
Standard wheels	<input type="checkbox"/>	<input type="checkbox"/>
Mounting of stiff, low profile tyres	<input type="checkbox"/>	<input type="checkbox"/>
Wheel with reverse rim	<input type="checkbox"/>	<input type="checkbox"/>
Bead lubrication for proper mounting	<input type="checkbox"/>	<input type="checkbox"/>
WDK procedure	<input type="checkbox"/>	<input type="checkbox"/>
<u>Accessories</u>		
Instructions for correct use of the accessories	<input type="checkbox"/>	<input type="checkbox"/>
Inflatron user instructions (optional)	<input type="checkbox"/>	<input type="checkbox"/>
<u>Inflation</u>		
Safety measures	<input type="checkbox"/>	<input type="checkbox"/>
Lubrication and removal of the valve insert	<input type="checkbox"/>	<input type="checkbox"/>
Tubeless tyre inflation	<input type="checkbox"/>	<input type="checkbox"/>

Individuals and Dates Trained



TRANSLATION FROM ORIGINAL LANGUAGE (ITALIAN)

Sommario

1. GETTING STARTED	82
1.1 INTRODUCTION	82
1.1.A. PURPOSE OF THE MANUAL	82
1.2 FOR YOUR SAFETY	82
1.2.A. GENERAL WARNING AND INSTRUCTIONS	83
1.2.B. DECAL PLACEMENT	86
1.2.C. ELECTRICAL AND PNEUMATIC CONNECTIONS	90
1.2.D TECHNICAL DATA	91
1.2.E. AIR PRESSURE	92
1.3. ADDITIONAL RIM/TYRE INFORMATION	93
1.4. INTENDED MACHINE USE	93
1.6. PRELIMINARY CHECKS	94
1.7. DURING USE.....	94
2. TRANSPORT, STORAGE AND HANDLING	95
3. ASSEMBLY/HANDLING	96
3.1. HOISTING/HANDLING	96
3.2. INSTALLATION	97
5. DESCRIPTION OF ARTIGLIO 5000	98
5.1. OPERATOR POSITION.....	99
5.2. OVERALL DIMENSIONS.....	99
5.3. EQUIPMENT COMPONENTS (MAIN WORKING OPERATING ELEMENTS OF THE MACHINE)	100
5.4. CONTROLS.....	103
5.4.A. CONTROL CONSOLE (FIG. 12).....	103
5.4.B. PEDAL UNIT (FIG. 13)	104
5.4.C. WHEEL LIFTER PEDAL UNIT (OPTIONAL) FIG. 14.....	105
5.4.D. PRESSURE GAUGE WITH DEFLATE BUTTON (FIG. 15)	105
6. BASIC PROCEDURES - USE	106
6.1. PRELIMINARY CHECKS	107
6.2. DECIDING FROM WHICH SIDE OF THE WHEEL THE TYRE MUST BE DEMOUNTED	107
6.3. WHEEL LOADING	108
6.4. CLAMPING THE WHEEL ON THE TURNTABLE	110
6.5. TYRE DEFLATION	112
6.6. BEAD BREAKING	112
6.7. DEMOUNTING PROCEDURE.....	115
6.8. MOUNTING	118

6.9. APPROVED UHP and RUN FLAT TYRE DEMOUNTING AND MOUNTING PROCEDURE	121
6.10. TYRE INFLATION	122
6.10.A. SAFETY REGULATIONS	122
6.10.B. TYRE INFLATION	123
6.10.C. SPECIAL PROCEDURE (TI VERSION)	124
6.11 UNCLAMPING THE WHEEL AND UNLOADING	126
6.11.A. WHEEL UNCLAMPING	126
6.11.B WHEEL UNLOADING	127
7. MAINTENANCE	127
Scheduled maintenance:	128
8. INFORMATION ABOUT SCRAPPING	130
9. ENVIRONMENTAL INFORMATION	130
10. INFORMATION AND WARNINGS ABOUT OIL	131
11. INFORMATION AND WARNINGS ABOUT TYRE LUBRICATING FLUID	131
12. RECOMMENDED FIRE EXTINGUISHING EQUIPMENT	132
13. GLOSSARY	133
TABLE FOR USING CENTRING AND CLAMPING ACCESSORIES ACCORDING TO RIM TYPE	137
WIRING DIAGRAM	145
PNEUMATIC DIAGRAM	146



1. GETTING STARTED

1.1 INTRODUCTION

1.1.a. PURPOSE OF THE MANUAL

The purpose of this manual is to provide the instructions necessary for optimum operation, use and maintenance of your machine. If you sell this machine, please deliver this manual to the new owner. Furthermore, ask the new owner to fill out the ownership transfer module attached to the previous page in the manual and send it to Corghi, so that Corghi will be able to provide the customer with all necessary safety information. Alternatively, the new owner can send an email to service@corghi.com.

This manual assumes that the technicians have full understanding regarding the identification and maintenance of rims and tyres. They must also have thorough knowledge regarding the operation and safety features of the relative tools (such as the rack, lift or the jack) that are used, as well as the manual or electric tools required to perform the work safely.

The first section provides basic information for the safe operation of the Artiglio 5000 tyre changer family. The following sections contain detailed information regarding equipment, procedures and maintenance. "Italics" are used to refer to specific parts of this manual that provide additional information or explanation.

These references should be read for additional information to the instructions being presented. The owner of the tyre changer is the only person responsible for the observance of the safety procedures and the organisation of technical training. The tyre changer must only be used by qualified, specifically trained technicians. The owner or management is exclusively responsible for storing the documentation relative to qualified personnel.

The Artiglio 5000 family of tyre changers is designed and manufactured for mounting, demounting and inflating tyres for light vehicles (passenger cars - not intended for use for trucks or motorcycles) with a maximum external diameter of 47 inches and a maximum width of 15 inches.

Copies of this manual and of the documents accompanying the machine may be obtained from Corghi by specifying the type of machine and its serial number.

NOTICE: Design details are subject to change. Some illustrations may vary slightly in appearance from the machine you have."

1.2 FOR YOUR SAFETY

HAZARD DEFINITIONS

These symbols identify situations that could be harmful to the safety of personnel and/or cause damage to the equipment.

 **DANGER**

 **DANGER:** Indicates an imminently hazardous situation which, if not avoided, will result in death or serious injury.

 **CAUTION!**

 **WARNING:** Indicates a potentially hazardous situation which, if not avoided, could result in death or serious injury.

 **WARNING**

 **CAUTION:** Indicates a potentially hazardous situation which, if not avoided, may result in minor or moderate injury.

CAUTION!

NOTICE: Used without the safety alert symbol indicates potentially hazardous situation, which, if not avoided, may result in property damage.

EN

1.2.a. GENERAL WARNING AND INSTRUCTIONS

 **CAUTION!**

Avoid Personal Injury. Carefully read, understand and follow the warnings and instructions given in this manual. This manual is an essential part of the product. Keep it with the machine in a safe place for future reference.

1. If the maintenance procedures described in this manual are not executed correctly, or if other instructions in the manual are not observed, accidents could occur. This manual makes continuous reference to the possibility that accidents can occur. Any accident could cause serious or fatal injuries to the operator or people nearby, or cause material damage.

2. Overinflated tyres can explode, producing hazardous flying debris that may result in an accident.
3. Tyres and rims that do not have the same diameter do not correspond. Never attempt to mount or inflate tyres and rims that do not correspond. For example, never mount a 16.5" tyre on a 16" rim, or vice versa. It is very dangerous. Tyres and rims that do not correspond could explode, causing accidents.
4. Never exceed the inflation pressure for the tyre indicated by the manufacturer on the side of the tyre itself. Carefully check that the air hose is well inserted in the valve
5. Never bring your head or other body parts close to a tyre during inflation or bead insertion operations. This machine is not a safety device against the possible explosion risk of tyres, air chambers or rims.
6. Maintain a suitable distance from the tyre changer while inflating. Do not approach it.



DANGER

A bursting tyre can cause projections of its parts in surrounding areas with a force sufficient to cause serious injury or death.

Do not mount a tyre if its dimensions (indicated on the side) do not correspond exactly with the rim dimensions (printed inside the rim) or if the rim or the tyre are defective or damaged.

Never exceed the pressure recommended by the tyre manufacturer.

The tyre changer is not a safety device and does not prevent tyres and rims from exploding. Keep other people at a distance

7. Crushing Hazard. Moving Parts Present. Contact with moving parts could result in an accident.

The machine may only be used by one operator at a time.

- Keep all bystanders clear of tire changer.
- Keep hands and fingers clear of rim edge during the demounting and mounting process.
- Keep hands and fingers clear of mount/demount head during operation.
- Keep hands and other body parts away from moving parts.
- Do not use tools other than those supplied with tyre changer.
- Use lubricant that is specific for tyres in order to prevent tyre seizure.
- Pay attention while handling the rim and tyre and while using the lever

8. Electric Shock Hazard.

- Do not clean the electric parts with water or high pressure air jets.

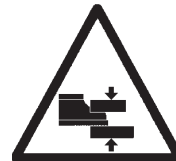

- Do not operate machine with a damaged power cord
 - If an extension is necessary, use a cable with nominal features equal to or greater than those for the machine. Cables with nominal features that are lower to those of the machine could overheat and cause a fire.
 - **Make sure that the cable is positioned so that no one will trip over it and it cannot be pulled.**
9. Hazard of eye injuries. During the bead insertion and inflation phase, debris, dust and fluids could be projected into the air. Remove any debris present in the tread of the tyre and on the tyre surface. Wear protective goggles with OSHA, CE approval or other certified devices during all work phases.
 10. Always inspect the machine carefully before using it. Missing, broken, or worn equipment (including warning stickers) must be repaired or replaced prior to operation.
 11. Never leave nuts, bolts, tools or other materials on the machine. They could remain trapped in moving parts and cause malfunctions or be projected out of the machine.
 12. DO NOT install or inflate tyres that are cut, damaged, decayed or worn. DO NOT install tyres on damaged, bent, rusted, worn or deformed rims
 13. If the tyre is damaged during the mounting phase, do not try to complete the mounting operation. Remove it and take it away from the service area, marking it as damaged.
 14. Inflate the tyres slowly, in steps, while checking the pressure, the tyre, the rim and the bead. NEVER exceed the pressure limits indicated by the manufacturer.
 15. The internal parts in this machine could create contacts or sparks if exposed to flammable vapours (petrol, paint thinner, solvents, etc.). Do not install the machine in a narrow area or below floor level.
 16. Do not operate the machine while under the influence of alcohol, medicine or drugs. If you are taking prescription or non-prescription medicine, contact a physician to understand the side effects that the medicine could have on the ability to operate the machine safely.
 17. Always use OSHA, CE approved and authorised personal protective equipment (PPE) or equipment with equivalent certification while operating the machine. Consult your supervisor for additional instructions.
 18. Remove jewelry, watches, loose clothing, ties and restrain long hair before using machine.
 19. Wear protective, non-slip footwear while using the tyre changer.
 20. Wear proper back support and employ proper lifting technique when placing, moving, lifting or removing wheels from the tire changer.
 21. Only suitably trained personnel can use, service and repair the machine. Repairs may only be performed by qualified personnel. Corghi technical personnel are the most qualified individuals. Employers must determine if an employee is qualified to carry out any machine repair safely if the operator has attempted to make the repair.











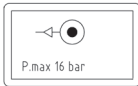

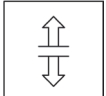







EN



22. The operator must pay close attention to the warnings on the equipment labels before starting the machine.
23. Clamp the rim on the wheel support plate during inflation.

1.2.b. DECAL PLACEMENT

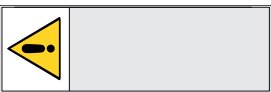
No.	Code	Label	Description
1	446429		LABEL, INPUT PRESSURE MAX. 16 BAR
2	446429		LABEL, ATTENTION TANK PRESSURISED
3	418135		LABEL, ROTATION DIRECTION
4	446665		LABEL, UNCLAMP CONTROL LABEL
5	-		LABEL, MODEL SERIAL NUMBER
6	4-105844		INVERTER MOTOR
7	4-103881		CORGI
8	4-122534		ARTIGLIO 5000
9	4-122231		CORGI TOUCHLESS TECHNOLOGY ADHESIVE LABEL
10	4-104346		LIFTER UP-DOWN PED. (OPTIONAL)

No.	Code	Label	Description
11	461932		TURNTABLE ROTATION
12	461933		INFLATION PED.
13	446436		DEFLATION PRESSURE GAUGE
14	461936		PROHIBITION OF TWO OPERATORS WORKING SIMULTANEOUSLY
15	346855		ADHESIVE SAFETY STRIP Y/B 50X130
16	462081		RISK OF CRUSHING
17	461930		RISK OF CRUSHING
18	462080		NOISE PROTECTION LABEL
19	461931		INFLATION WARNING PLATE
	462778		USA HAZARD PLATE
20	4-122775		WDK APPROVAL

EN

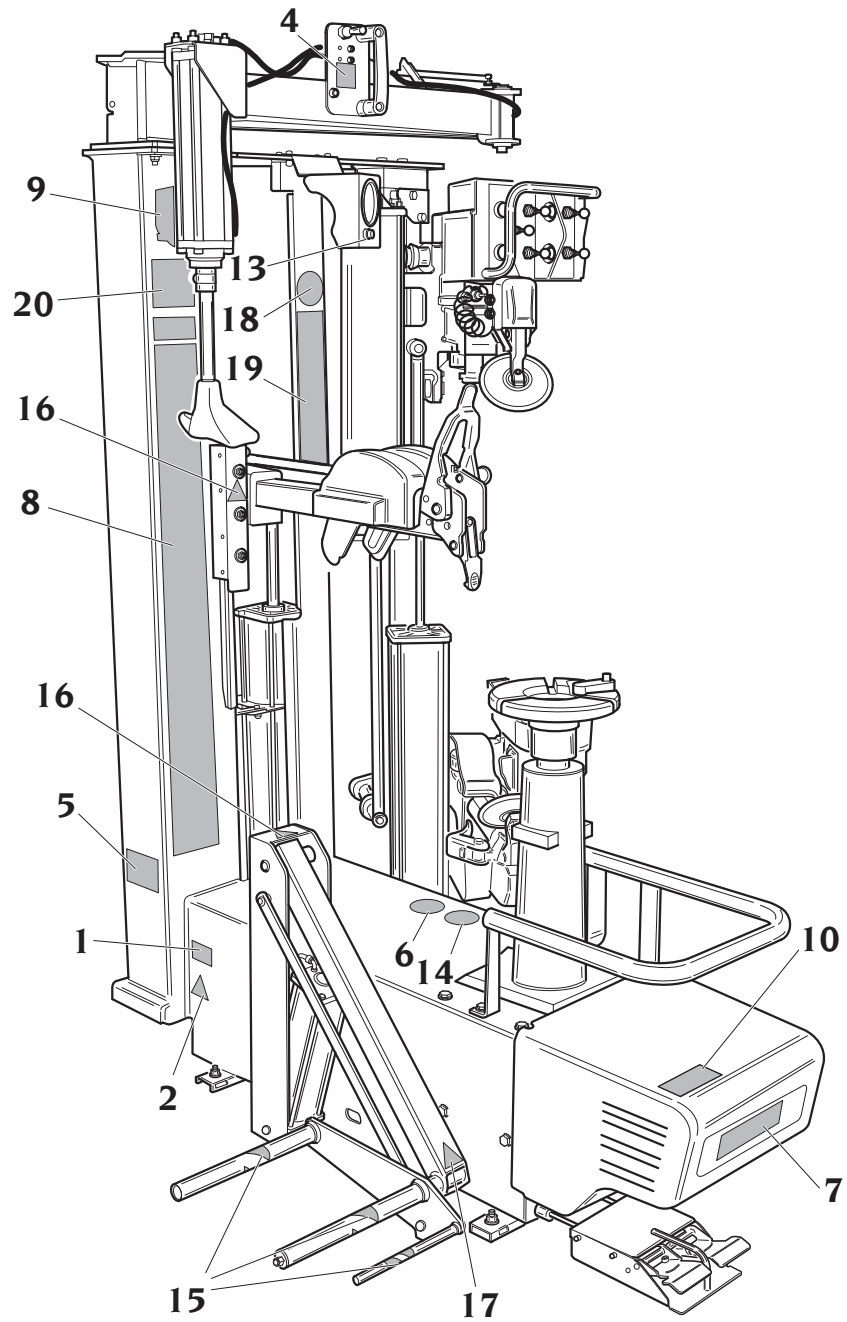

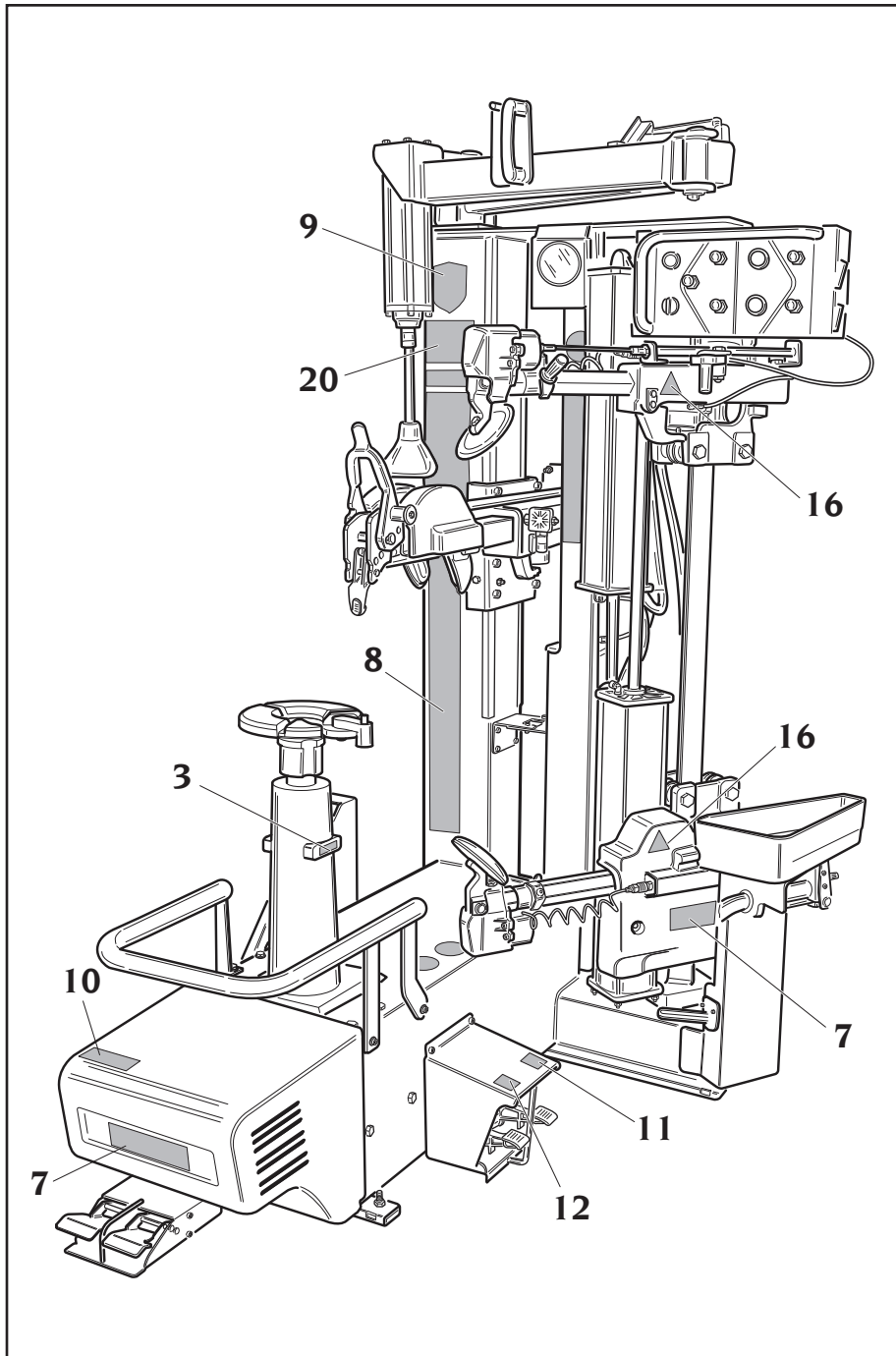

EN

DANGER WARNING DECALS



P/N. 462081 Risk of crushing



part n. 461930 Risk of crushing



Part n. 461936. Never stand behind the machine.
Only one operator may operate and use the machine



part n. 446442. Danger - pressurised container



part n. 425211A. Risk of electrocution.



part nr 425083. Earth ground terminal.

1.2.c. ELECTRICAL AND PNEUMATIC CONNECTIONS

The electric hook-up used must be suitably sized:

- for the electric power absorbed by the machine, indicated on its data plate (Fig. 1);
- the distance between the machine and the power supply hook-up point, so that voltage drops under full load do not exceed 4% (10% during start-up) compared with the rated voltage specified on the data plate.

- The operator must:

- fit a plug that respects the current regulations onto the power supply cable;
- connect the machine to its own electrical connection - A, Fig. 2 - and fit a differential safety circuit-breaker with 30 mA residual

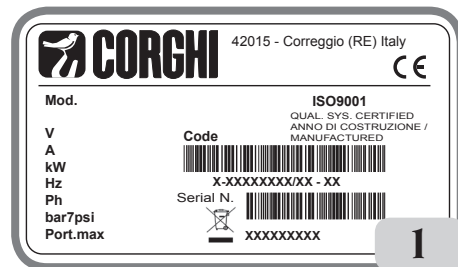

- current;
- install protection fuses on the power line that are suitably sized in accordance with the indications provided on the machine data plate (Fig. 1);
- connect the machine to an industrial socket; the machine must not be connected to domestic sockets.

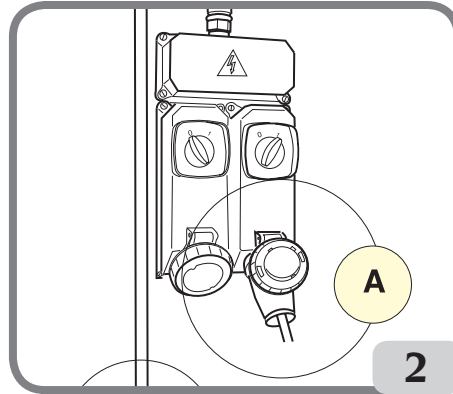

CAUTION!

An effective grounding connection is essential for correct operation of the machine.

Make sure that the available pressure and performance of the compressed air system are compatible with what is necessary for correct machine operation - see the section "Technical data". For correct machine operation, the compressed air supply line must provide a pressure range from no less than 8.5 bar to no more than 16 bar and guarantee an air flow rate greater than the average consumption of the machine, which is equal to 140 NI/min (see technical data).

CAUTION!

For correct equipment operation, the air produced must be suitably treated (not above 5/4/4 according to ISO 8573-1).

EN

1.2.d TECHNICAL DATA

- **Compatible tyre types:** CONVENTIONAL – LOW PROFILE - RUN FLAT - BALOON - BSR

- **Wheel dimension range:**
 - wheel diameter from 13" to 28"
 - maximum tyre diameter 1200 mm (47")
 - maximum tyre width 15" (from wheel mating surface)

- **Turntable:**
 - resting side: flanged
 - centring on cone
 - clamping manual
 - drive system 2-speed motor-inverter
 - rotation torque 1200 Nm

- rotation speed 7-18 rpm
- **Bead breaking unit:**
 - tool: disc
 - positioning in relation to rim: manual with mechanical clamping
 - penetration: guided
 - Bead breaking cylinder force 7600N
- **Wheel lifter (optional):**
 - operation automatic lift/manual tilt
 - activation: pneumatic
 - lifting capacity 85 Kg
- **Electrical power:**
 - 1 Ph 230V - 0.75 kW - 50/60 Hz
 - 1 Ph 110V - 0.75 kW - 50/60 Hz
- **Compressed air supply:**
 - operating pressure: 8 -10 bar
- **Weight** 425 kg (with lifter)
 - weight of electric/electronic parts 10 kg
- **Noise level:**
 - A-weighted sound pressure level (LpA) at the working position < 70 dB (A)

The noise levels indicated correspond to emission levels and do not necessarily represent safe operating levels. Although there is a relationship between emission levels and exposure levels, this cannot be used reliably to establish whether or not further precautions are necessary. The noise levels to which the operator is exposed to depend on a number of factors, such as duration of exposure, characteristics of the workplace, other sources of noise etc. . Permissible noise exposure limits may also vary from country to country. However, this information will enable machine users to make a more accurate assessment of hazards and risks.

1.2.e. AIR PRESSURE

The machine is equipped with an internal pressure limiting valve to minimize the risk of over inflating the tyre.

	<div style="background-color: red; color: white; padding: 5px; text-align: center;">  DANGER </div> <ul style="list-style-type: none"> • EXPLOSION HAZARD • Do not exceed the pressure recommended by the tyre manufacturer. Always match the tyre and rim dimensions. • Avoid personal injury or death
---	--

1. Never exceed these pressure limitations:

- The supply circuit pressure (from the compressor) is **220 psi (15 bar)**.
- The operating pressure (indicated on the regulator) is **150 psi (10 bar)**.
- The tyre inflation pressure (displayed on the pressure gauge) must never exceed the pressure indicated by the manufacturer on the sidewall of the tyre itself.

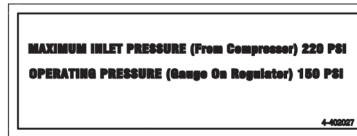

2. Activate the air inflation jets only when inserting the bead.
3. Discharge the air pressure system before disconnecting the power supply or other pneumatic components. The air is stored in a tank for operating the inflation jets.
4. Activate the air inflation jets only if the rim is correctly clamped on the tyre changer (if required) and the tyre is completely mounted.

1.3. ADDITIONAL RIM/TYRE INFORMATION

CAUTION!

Wheels equipped with pressure sensors and special rims or tyres could require particular work procedures. Consult the service manuals from the manufacturer of the wheels and tyres.

1.4. INTENDED MACHINE USE

This machine must only be used to demount and mount vehicle tyres from/on the rims, using the provided tools. Any other use is considered inappropriate and may cause accidents. The machine is not designed for working with motorcycle wheels.

EN

1.5. PERSONNEL TRAINING

1. Employers are responsible for providing a training program for all employees who work on the wheels concerning the hazards deriving from maintenance and the safety procedures to be observed. Service and maintenance refers to mounting and demounting wheels and all the correlated activities, such as inflation, deflation, installation, removal and handling.
 - Employers are required to make sure that operators do not work on the wheels unless they have received suitable training regarding the correct maintenance procedures for the type of wheel being serviced and the operative safety procedures.
 - Information to be used for the training program includes, as a minimum, the information contained in this manual.

2. Employers are required to make sure that every employee demonstrates and maintains the ability to work on the wheels safely, including the performance of the following activities:
 - Demounting tyres (including deflation).
 - Inspecting and identifying rim wheel components.
 - Tyre mounting.
 - Using any restraining device, cage, barrier, or other installation.
 - Handling rim wheels.
 - Tyre inflation.
 - Move away from the tyre changer while inflating the tyre and do not lean forward when inspecting the wheel during inflation.
 - Wheel installation and removal.
3. Employers must evaluate the ability of their employees to carry out these tasks and work on the wheels in absolutely safety and must provide additional training as required to make sure that all employees maintain their skills.

1.6. PRELIMINARY CHECKS

Before starting to work, carefully check that all machine components, particularly rubber or plastic parts, are in place, in good condition and operate correctly. If damage or excessive wear is found during the inspection phase, replace or repair the component immediately regardless of the amount of damage or wear.

1.7. DURING USE

If strange or unusual noises are heard, if a component or system is not operating correctly or if you observe anything unusual, immediately stop using the machine.

- Identify the cause and take any necessary remedial action.
- Contact your supervisor if necessary.

Make sure that all other people are positioned at least 6 metres (20 feet) from the machine.

To stop the machine in an emergency:

- disconnect the power supply plug;
- interrupt the compressed air supply by disconnecting the supply pipe.

2. TRANSPORT, STORAGE AND HANDLING

Conditions for transporting the machine

The tyre changer must be transported in its original packaging and stowed in the position shown on the packaging itself.

- Packaging dimensions:

- width 1150 mm
- depth 1950 mm
- height 2100 mm

- Weight of wooden crate:

- Standard version 520 kg

Machine storage and shipping specifications

Temperature: -25° - +55°C.

CAUTION!

Do not stack other goods on top of the packing or damage may result.

Handling

To move the packing, insert the tines of a fork-lift truck into the slots on the base of the packing itself (pallet) (Fig.3).

Before moving the machine, refer to the HOISTING/HANDLING section.

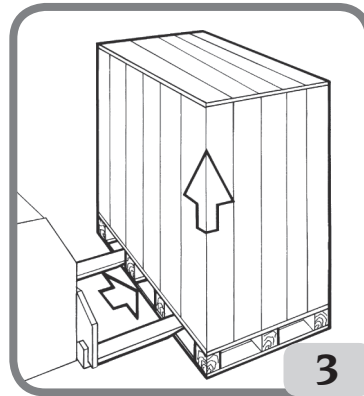

EN

CAUTION!

Keep the original packing in good conditions to be used if the equipment has to be shipped in the future.

3. ASSEMBLY/HANDLING

CAUTION!

Pay careful attention when unpacking, assembling, handling and installing the machine as described below. Failure to observe these instructions could damage the machine and compromise operator safety.

- Remove the upper part of the cardboard packaging and make sure the machine has not been damaged during transport. identify the fastener points (H, fig. 4) onto the pallet.

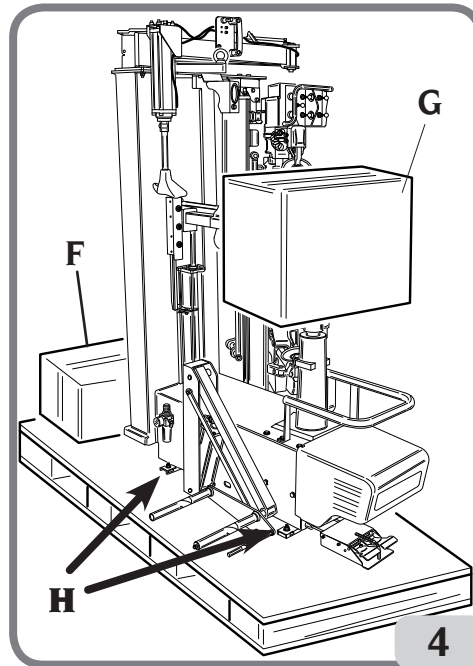

3.1. HOISTING/HANDLING

CAUTION!

Before removing the machine from the pallet, make shure the items showed below have been removed from the pallet.

- Equipment (F, Fig. 4)
- TI unit (optional) (G, Fig. 4)

To lift the machine from the pallet, remove the screws from the fastener feet (H, Fig. 4) and secure it with the hoisting bracket (Fig. 5). This hoisting point must be used whenever you need to change the installation position

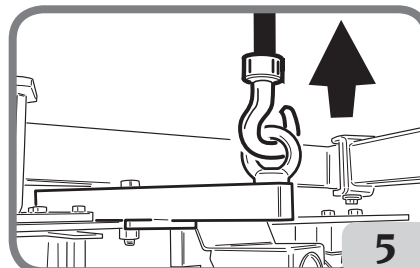

of the machine.

Do not attempt to move the machine until it has been disconnected from the electricity and compressed air supply systems.

3.2. INSTALLATION

- Remove the hoisting bracket, unscrewing the screws and washers (Fig.6)
- Connect the machine to the power supply and the compressed air supply
- T.I. (optional): see specific installation manual.

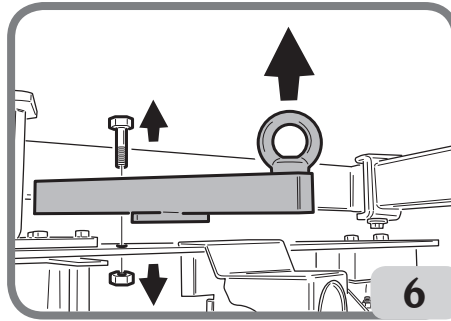

4. INSTALLATION AREA



Install the machine in compliance with all the applicable safety standards, including, but not limited to, those issued by OSHA.

Do not install the machine outdoors. It is designed to be used in closed, covered areas.

Install the tyre changer in the chosen work position, complying with the minimum clearances shown in **fig.7**

The support surface must have a load-bearing capacity of at least 1000 kg/m².

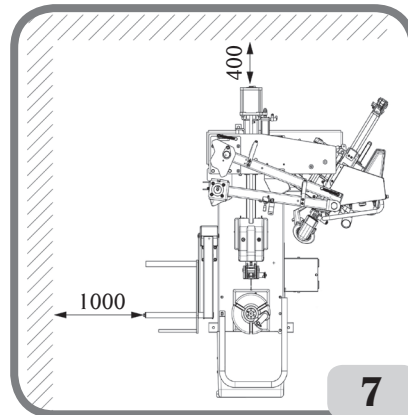

EN



DANGER

RISK OF EXPLOSION OR FIRE. Do not use the machine in areas that could be exposed to inflammable vapours (petrol, paint solvents, etc.).
Do not install the machine in a narrow area or below floor level



WARNING

IMPORTANT: for the correct and safe operation of the machine, the lighting level in the place of use should be at least 300 lux.

Work environment conditions

- Relative humidity 30% - 95% without condensation.
- Temperature 0°C ÷ 50°C.

5. DESCRIPTION OF ARTIGLIO 5000

The Artiglio 5000 is an electropneumatic universal tyre changer for changing passenger car, off-road and light commercial vehicle tyres. The Artiglio 5000 is capable of bead breaking, demounting and mounting any type of tyre with rim sizes from 13" to 28" with extreme ease

Additional improvements were made:
- to reduce the physical exertion of the operator;
- to guarantee rim and tyre safety;
- to automate, as far as possible, operations that up until now have been manually performed by the operator.

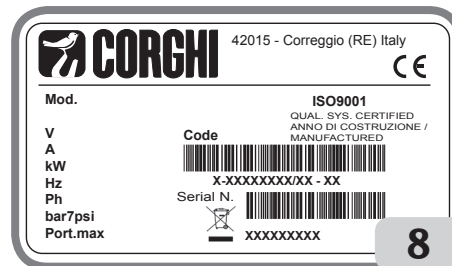

Each machine has a data plate Fig. 8, with information about the machine and some technical data.

As well as the manufacturer's details, the plate indicates:

- Mod. - Machine model;
- V - power supply voltage in Volts;
- A - Input voltage in Amperes;
- kW - Absorbed power in kW;
- Hz - Frequency in Hz;
- Ph - Number of phases;
- bar - Operating pressure in bar;

Serial N. - the machine serial number;
ISO 9001 - Certification of the company's Quality System;
EC - EC marking.

5.1. OPERATOR POSITION

Figure 9 shows the position of the operator during the different stages in operation of the machine.

- A Loading and unloading the wheel
- B Demounting / mounting / inflating tyre

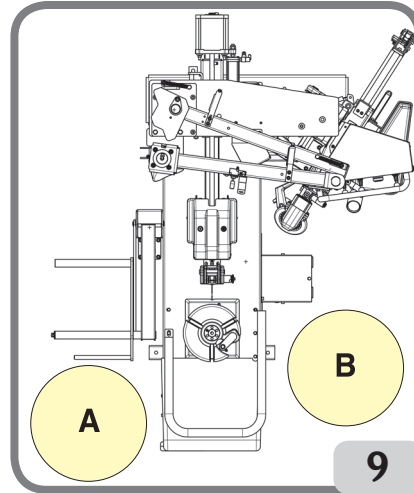

CAUTION!

In these conditions, the operator can move away, monitor and check every tyre change operations and take action in the case of any unforeseen events.

5.2. OVERALL DIMENSIONS

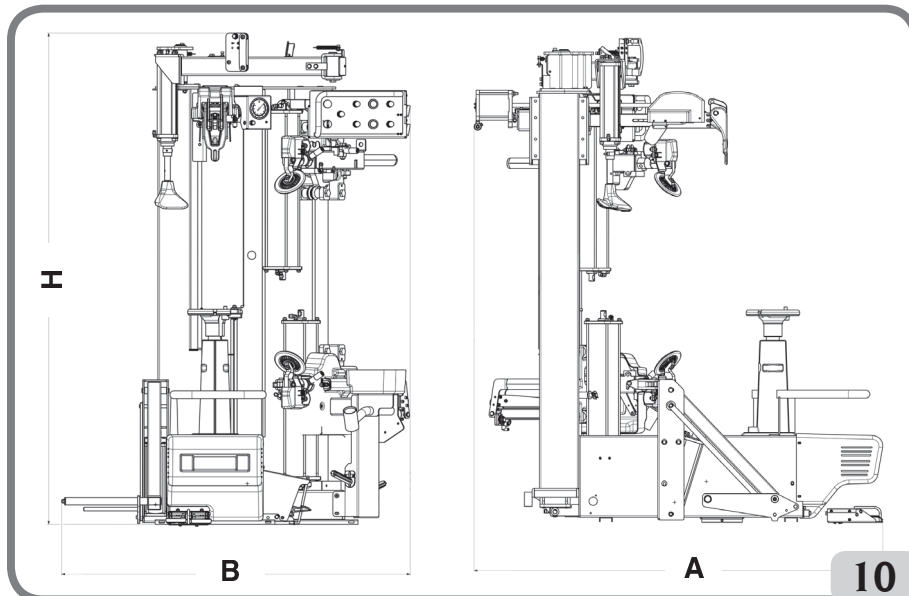

EN

- Depth (with lifter) A = 1575 mm
- Width (with lifter) B = 1315 mm
- Maximum height H = 1860 mm

5.3. EQUIPMENT COMPONENTS (MAIN WORKING OPERATING ELEMENTS OF THE MACHINE)

The main parts of the machine are indicated in fig. 11a-11b

- 1) Control console
- 2) Pressure gauge with deflation push-button
- 3) Frame
- 4) Upper bead breaker disc
- 5) Upper bead breaker arm extend lever
- 6) Mounting tool open/close latch
- 7) Lower bead breaker disc
- 8) Movable tool
- 9) Tool head
- 10) Fixed tool
- 11) Bead pressing tool
- 12) Centring handle
- 13) Wheel lifter (optional)
- 14) Wheel support plate
- 15) Grease holder
- 16) Pedal unit
- 17) Wheel lifter pedal unit (optional)
- 18) Filter-regulator unit
- 19) Tank (optional)
- 20) T.I. (optional)
- 21 Lower hook for demounting lower bead

CAUTION!

Know your machine! Understanding exactly how the machine works is the best way to work safely and efficiently. Learn the functions and positions of all controls. Carefully check that all controls work correctly. To prevent the risk of accidents or damage, the machine must be installed and operated correctly, and maintenance must be performed regularly.

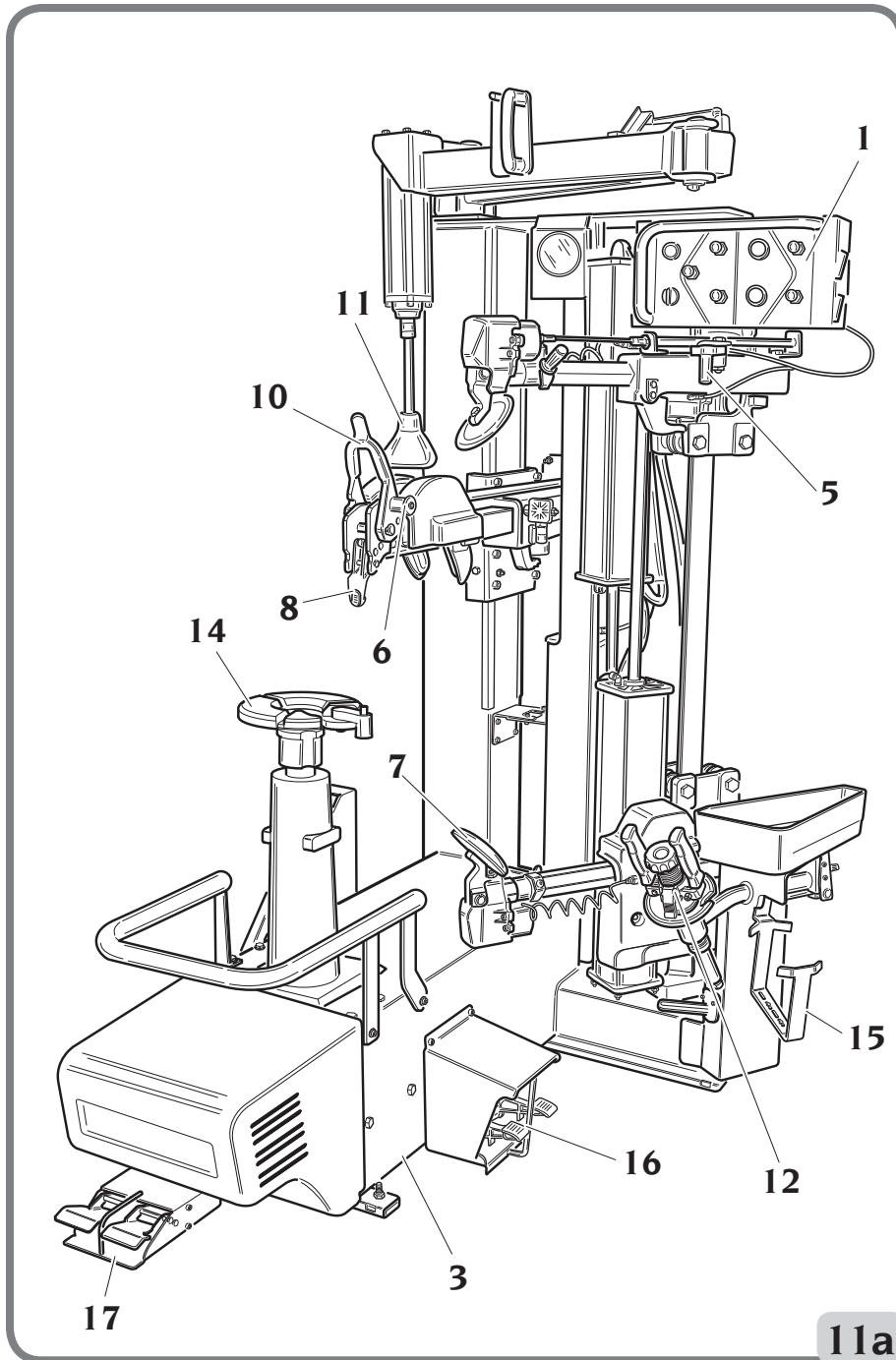

EN

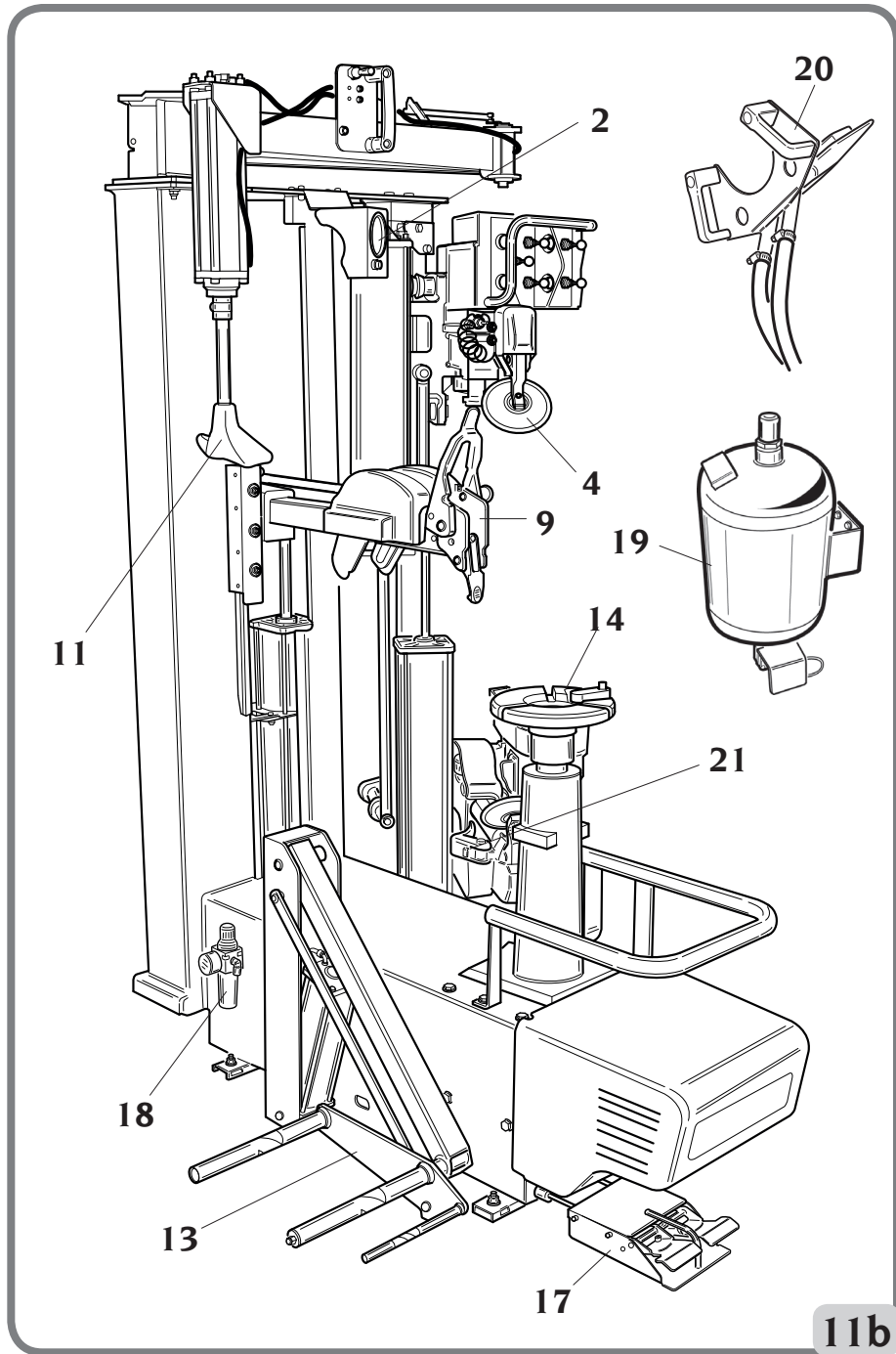

11b

⚠ CAUTION!

With regard to the technical characteristics, warnings, maintenance and any other information about the air tank (optional), consult the relevant operator's and maintenance manual provided with the documentation of the accessory.



5.4. CONTROLS

5.4.a. CONTROL CONSOLE (FIG. 12)

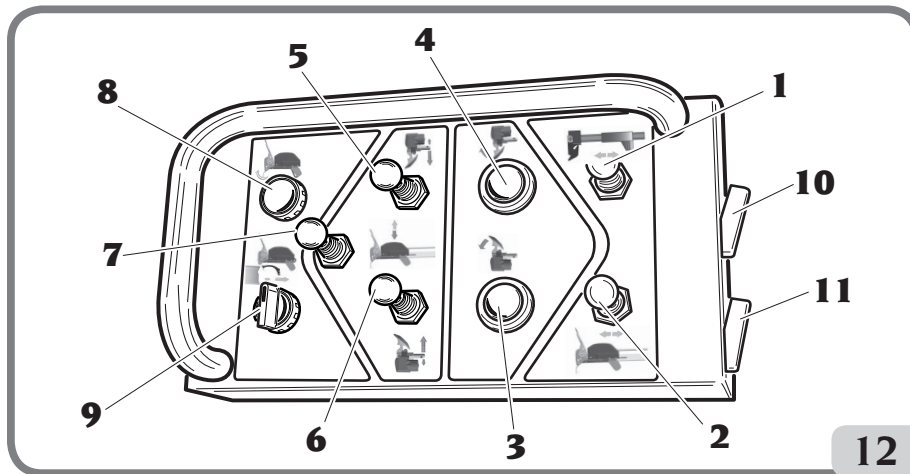

EN

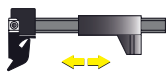

1 - Control lever for simultaneous upper and lower bead breaker disc horizontal movement.

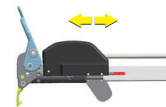

2 - Tool head horizontal movement control lever.



3 - Lower bead breaker disc penetration button



4 - Upper bead breaker disc penetration button

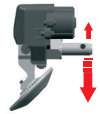

5 - Control lever for upper bead breaker disc vertical movement.



6 - Control lever for lower bead breaker disc vertical movement.

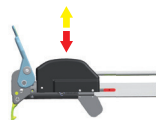

7 - Tool head vertical movement control lever.



8 - Button operating movable tool to select upper bead.

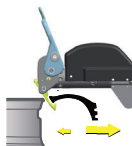

9 - Selector operating movable tool to demount upper bead.

10 - Upper and lower bead breaker disc horizontal movement unlock button.

11 - Tool head horizontal movement unlock button.

5.4.b. PEDAL UNIT (FIG. 13)



1 - Inflation pedal.



2 - Turntable rotation pedal.

The pedal has 4 different operating positions, each corresponding to a rotation speed.

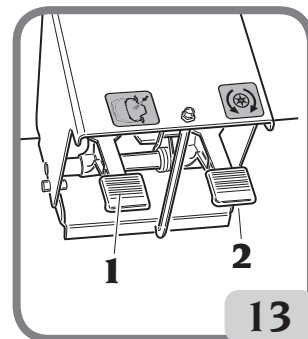

13

- pedal raised (unstable position): slow anticlockwise rotation. If the pedal is kept raised for more than 4 seconds, rotation gets faster (always anticlockwise).
- pedal in the rest position (stable position): turntable stopped
- pedal gently pressed downwards (unstable position): slow clockwise rotation
- pedal pressed entirely downwards (unstable position): fast clockwise rotation

5.4.c. WHEEL LIFTER PEDAL UNIT (optional) FIG. 14



1 - Pedal pressed (unstable position): hands-on wheel lifting



2 - Pedal pressed (unstable position): hands-on wheel lowering

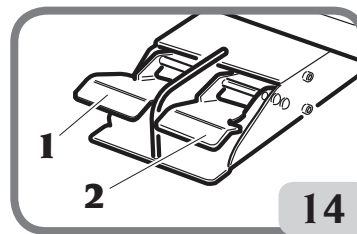

5.4.d. PRESSURE GAUGE WITH DEFLATE BUTTON (FIG. 15)

- 1- Pressure gauge displaying air pressure, with pedal regulation
- 2- Deflation button

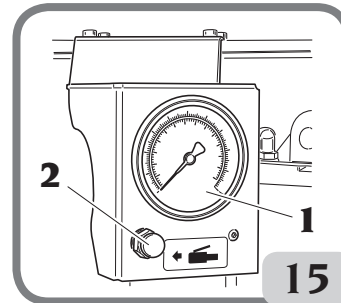

EN

6. BASIC PROCEDURES - USE

CAUTION!

CRUSHING HAZARD:

Some parts of the machine, such as the head, the bead breakers and turntable move by themselves.

Do not approach moving parts of the machine. Only work from the positions indicated in the relative paragraph.

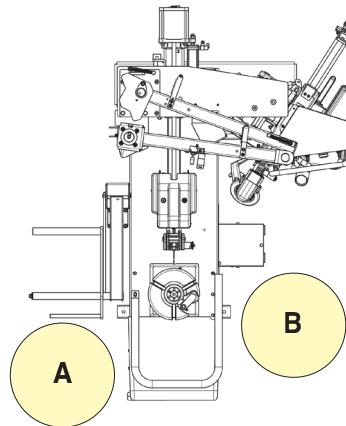

CAUTION!

RISK OF INJURY

Before using the machine: Disconnect the power supply Fig. 16; Isolate the compressed air line by disconnecting the delivery hose (quick-release connector) Fig. 17

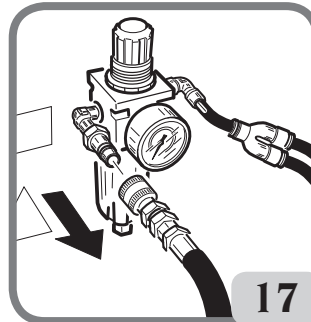
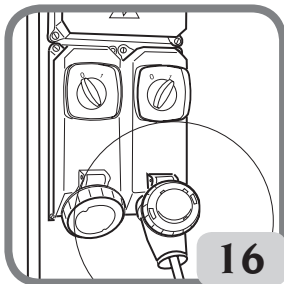

CAUTION!

Use only original spare parts to prevent the risk of damage or uncontrolled movements of the machine

6.1. PRELIMINARY CHECKS

Check that there is a pressure of at least 8 bar on the Filter Regulator pressure gauge. If the pressure is below the minimum level, some machine operations may be limited or insufficient.

After the correct pressure has been restored, the machine will function properly.

Check that the machine has been connected correctly to the mains electricity supply and the compressed air supply.

6.2. DECIDING FROM WHICH SIDE OF THE WHEEL THE TYRE MUST BE DEMOUNTED

See Fig. 18. Identify the position of rim well A on the wheel. Find the largest width B and the smallest width C. The tyre must be mounted and demounted with the wheel on the turntable with the smallest width side C facing upwards.

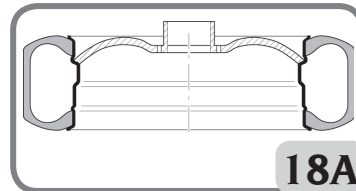

CAUTION!

See the paragraph "TABLE FOR USING CENTRING AND CLAMPING ACCESSORIES ACCORDING TO RIM TYPE" in this manual.

When working with easily damaged wheels
When working with "easily deformable" rims (i.e. a central hole with thin, projecting edges - see Fig. 18A) we recommend using the universal flange for blind rims (see the section "TABLE FOR USING CENTRING AND CLAMPING ACCESSORIES IN RELATION TO RIM TYPE" in this manual).

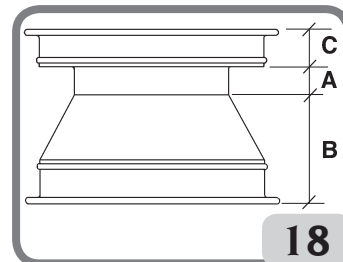

EN

SPECIAL WHEELS

Alloy rim wheels: some wheels with alloy rims have a minimum A rim well or do not have any well - **Fig. 18B**. These rims are not approved by DOT standards (Department of Transportation). The DOT initials certify that tyres comply with the safety standards adopted by the United States and Canada (these wheels cannot be sold in these markets).

High performance wheels (asymmetric curvature) - Fig. 18C some European wheels have rims with a very pronounced curvature C, except in the area of the valve

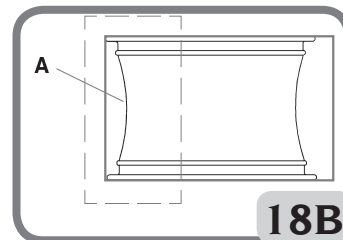

hole A where the curvature is less pronounced B. On these wheels the bead must first be broken in the area of the valve hole, on both the top and bottom sides.

Wheels with pressure sensor - **Fig. 18D**. To work correctly on these wheels and avoid damaging the sensor (which can be incorporated in the valve, secured to the belt, glued inside the tyre, etc.) suitable mounting/demounting procedures must be observed (refer to "Approved mounting/demounting procedure for runflat and UHP tyres").

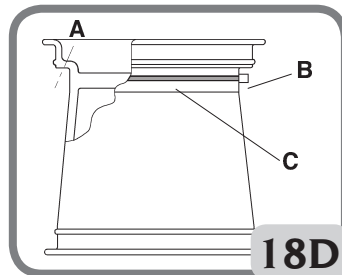
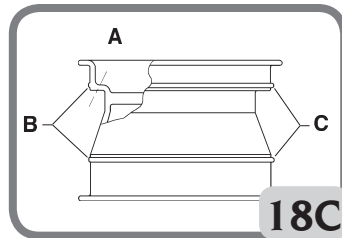

CAUTION!

Remove the old weights from the rim before starting work operations.

6.3. WHEEL LOADING

! CAUTION!

Only use the lifter pedals when loading and unloading the wheel.
Do not press these pedals during any other procedures!

- Load the wheel onto the wheel lifter (Fig. 19).

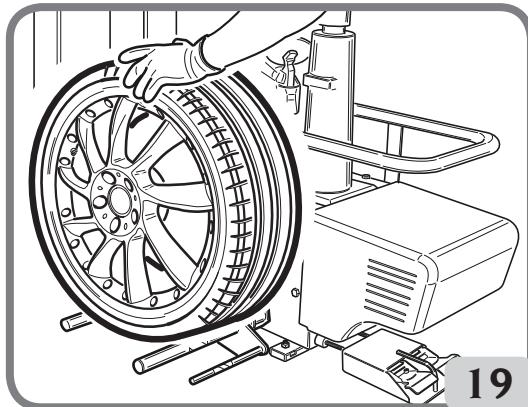

- Press the UP pedal to lift the wheel (Fig. 20).

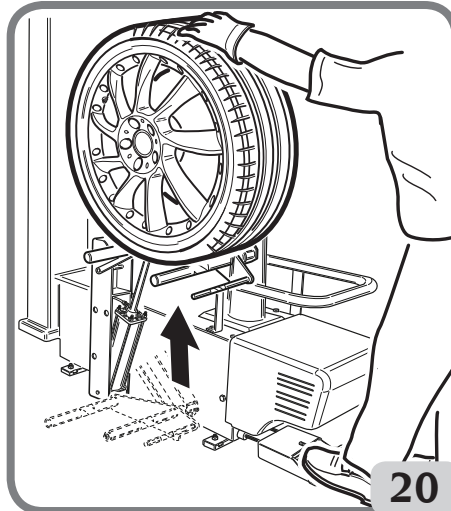

- Manually load the wheel onto the turntable and press the DOWN pedal to lower the lifter (Fig. 21).

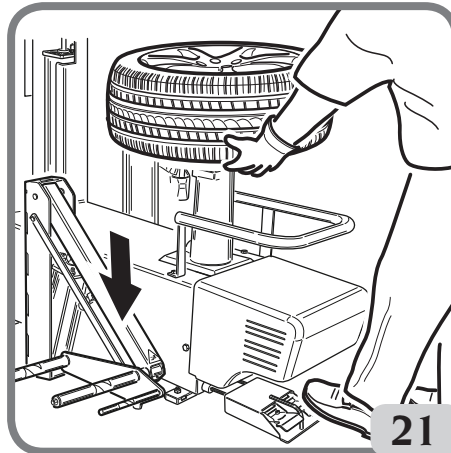

EN

- When positioning the wheel on the turntable, also make sure that the movable pin, situated radially on the turntable, is centred correctly in one of the fastener bolt holes (Fig. 22).

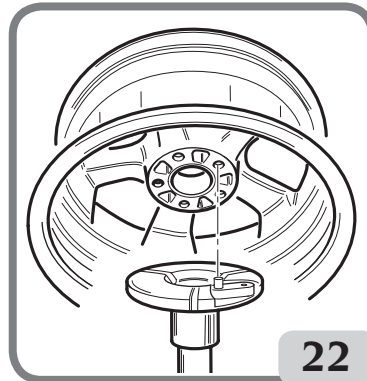

6.4. CLAMPING THE WHEEL ON THE TURNTABLE

- Insert the clamping handle in the central hole of the wheel (Fig. 23)

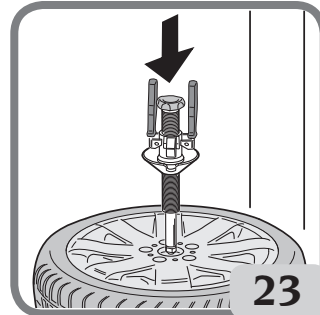

- Turn the handle to engage correctly with the turntable (Fig. 23a)

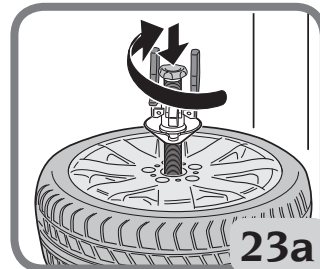

- Manually move the centring cone into position against the wheel by moving the retainers "1" (Fig. 23b)

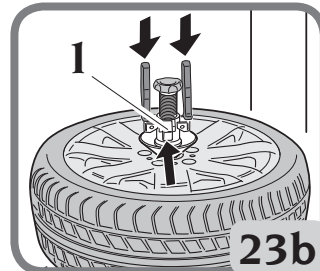

- Tighten the clamping device by turning the handle clockwise (Fig. 23c)

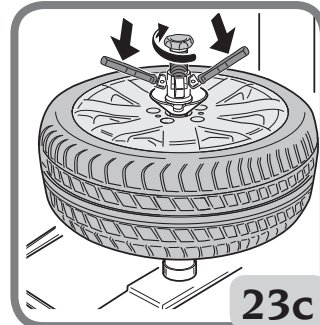

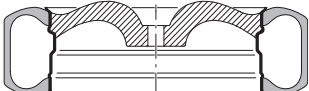
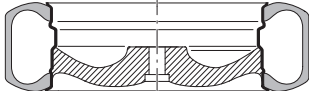
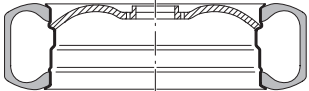
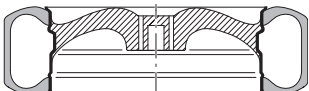
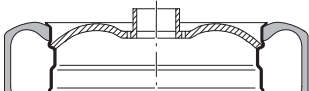

TABLE FOR USING CENTRING AND CLAMPING ACCESSORIES ACCORDING TO RIM TYPE

	A	Standard rim
	B	Dropped centre hole rim
	C	Reversed rim
	D	Pick-up rim
	E	Rim without central hole
	F	Open centre rim

EN

 **CAUTION!**

**CRUSHING POINT - MOVING PARTS. Risk of injuries due to crushing.
Keep hands away from the handle or cone during clamping**

6.5. TYRE DEFLATION

Completely deflate the tyre, using the valve (Fig. 24)

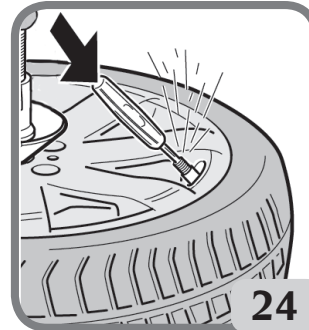



6.6. BEAD BREAKING

⚠ CAUTION!	⚠ CAUTION!	⚠ CAUTION!
		
<p>KEEP YOUR HANDS AND OTHER BODY PARTS AWAY FROM MOVING PARTS</p>	<p>KEEP FEET CLEAR OF THE BEAD BREAKER AND LIFTER</p>	<p>DO NOT PERFORM BEAD BREAKING IF THERE IS AIR IN THE TYRE</p>

⚠ CAUTION!

All air pressure inside the tyre must be removed before proceeding. Never attempt to break the bead until all air is removed from the tyre. Failure to remove all air from tyre may result in injury to operator, or damage to equipment, tyre, or wheel.

1 - Applying the upper bead breaker (fig. 25)

- Operate the lever  of the upper bead breaking unit to lower the unit from the rest position to the working position.
- First press the button  (10, Fig. 12) and then use the lever  to bring the disc towards the wheel.

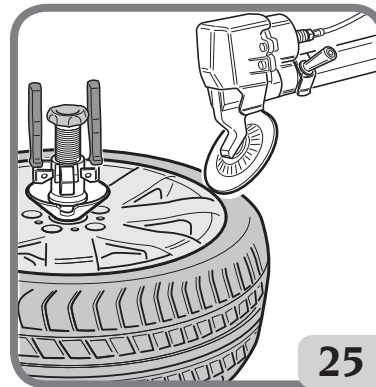

⚠ CAUTION!

Both arms move simultaneously during this procedure. Before starting, check that the lower arm is in the rest position (completely lowered).

- Once the required distance is reached (a gap of 2-3 mm should be left between the edge of the wheel and the bead breaker disc), release the button and the lever to inhibit any further horizontal movement.

2 – Breaking the upper bead

- Operate the lever  to preload the bead breaker disc (fig. 26). A preload compressing the tyre by approximately 5 mm is recommended.

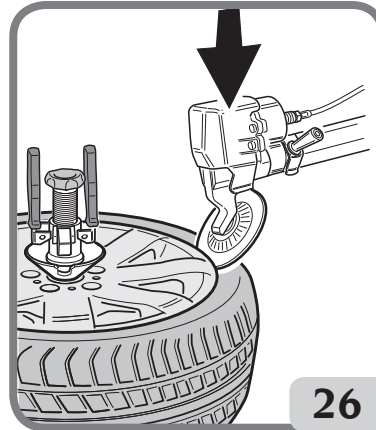

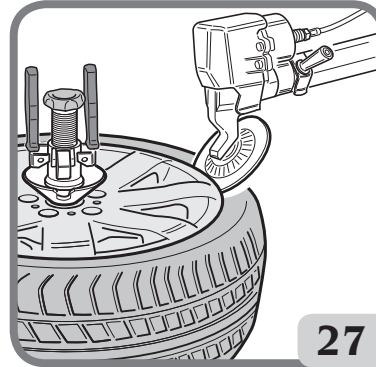

- Press the upper bead breaker disc penetration button  (Fig. 27)

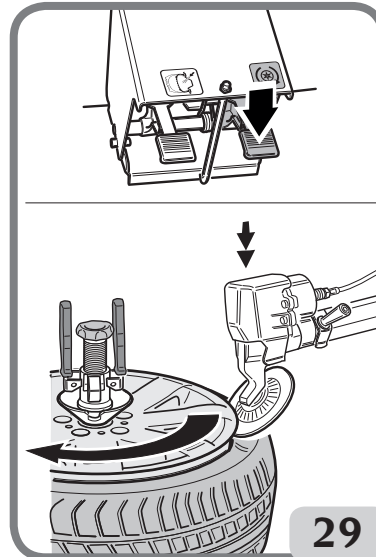

- Grease the bead to facilitate the bead breaking process (Fig. 28).
- Press the pedal (2, fig. 13) to turn the turntable.

- Tap the control  to lower the bead breaker disc in small steps and remove the bead completely from the seat on the wheel (Fig. 29).



- Perform at least one full turn to break the bead.
- Raise the lever  to automatically stop bead penetration and move the disc away from

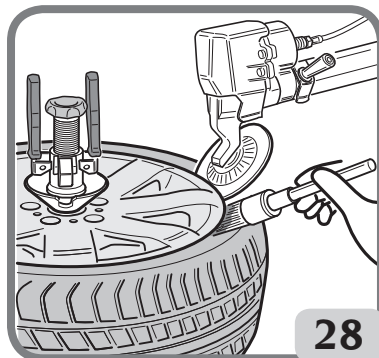

EN

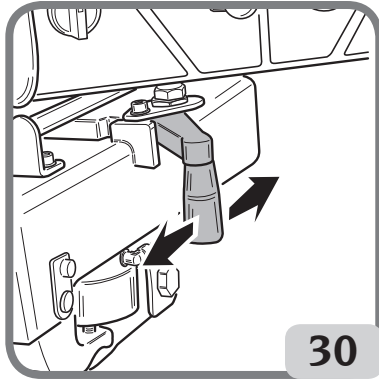

the working area, and raise the entire unit out of the work area.
The arm may be extended with the lever (fig. 30) to further clear the work area of any obstructions.

3- Applying the lower bead breaker .

- Operate the lever  of the lower bead breaking unit to raise the unit from the rest position to the working position (Fig. 31).

NB: The correct horizontal position of the lower arm is attained automatically when the upper arm is positioned correctly.

A gap of 2-3 mm should be left between the edge of the wheel and the bead breaker disc.

4 – Breaking the lower bead.

- Operate the lever  to preload the bead breaker disc (fig. 32). A preload compressing the tyre by approximately 5 mm is recommended.

- Press the lower bead breaker disc penetration

button  (Fig. 33)

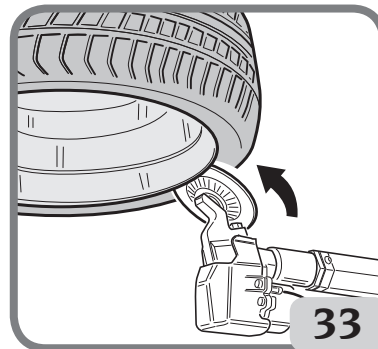
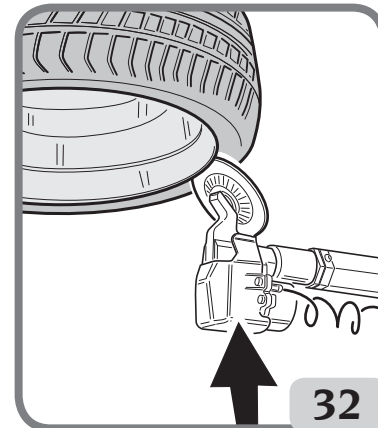
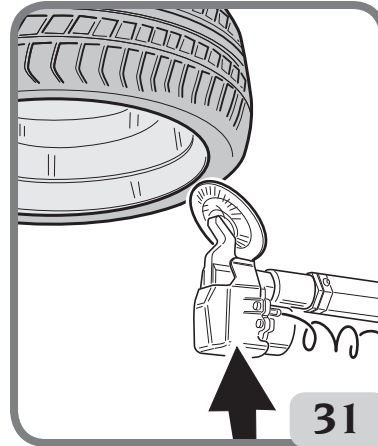

- Grease the bead to facilitate the bead breaking process (Fig. 34).

- Press the pedal (2, fig.13) to turn the turntable.

- Tap the control  to raise the bead breaker disc in small steps and remove the bead completely from the seat on the wheel (Fig. 35).

- Perform at least one full turn to break the bead.

- Lower the lever  to automatically stop bead penetration and move the disc away from the working area, and lower the entire unit out of the work area.

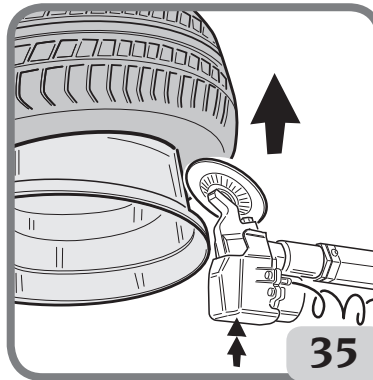
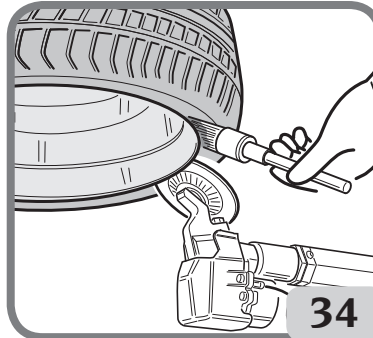

6.7. DEMOUNTING PROCEDURE

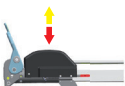
- Lower the head lever  to lower the head from the rest position to the working position.

- First press the button (11, Fig. 12) and then use the

lever  to bring the moveable tool towards the wheel (Fig. 36).

A gap of 3-4 mm should be left between the edge of the wheel and the bead breaker disc.

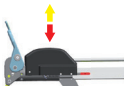
- Operate the lever  to insert the movable tool completely under the bead (Fig. 37).

- Hold the button  to engage with the bead (Fig. 38).

- Press the pedal (2, fig.13) to turn the turntable. If necessary, operate the control to lower the head

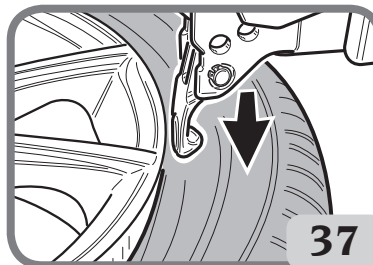
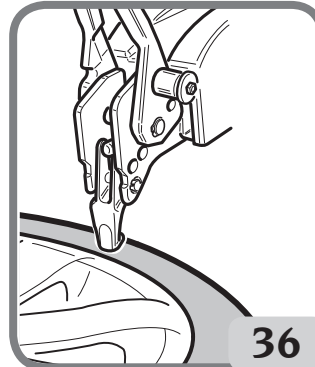

EN

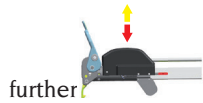

further

- After hooking onto the bead (Fig. 39), release

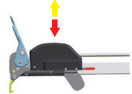

the button to return the tool to the rest position.

- Operate the lever  to raise the movable tool until the horizontal line on the tool is completely visible (Fig. 40-41).

- Ensure that the bead of the underside of the tyre is completely broken. If not repeat the procedure to break the bottom bead.

- Ensure that the bead situated at 180° relative to the tool is in the well. If not, use the bead depressor tool to position the bead correctly.



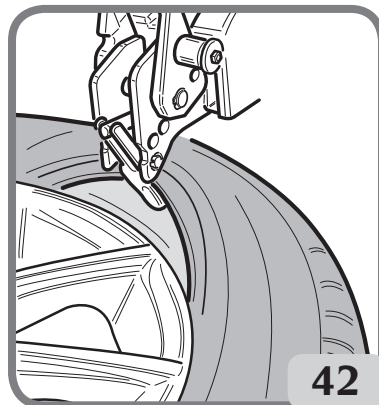
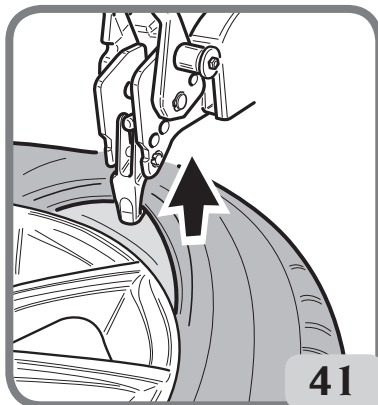
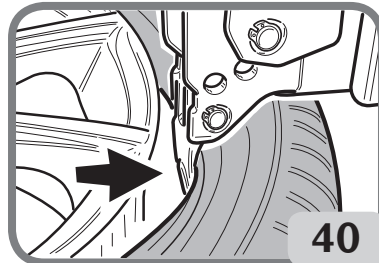
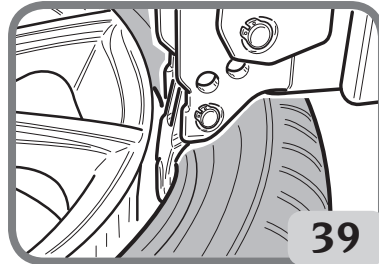
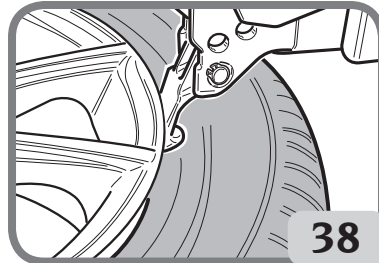

- Turn the selector  (Fig. 42).

- To facilitate the demounting process, push and lift the tyre with the lower bead breaker disc as needed to take the load off the mobile hook.



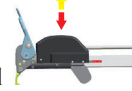

- While keeping the selector  turned, press the pedal (2, fig.13) to turn the turntable and demount the upper side of the tyre from the wheel (Fig. 43). If necessary, operate the

control  to slightly raise the head and complete top bead removal.

- Release the selector  and the pedal (2, fig.13).

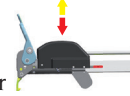
- Manually detach the tyre from the mobile hook.

- Raise the lever  to move the movable tool out of the work area and disengage the head.

- Operate the lever  to raise the bottom bead breaker disc (Fig. 44) to approximately 5 mm above the upper edge of the wheel (Fig. 45).

- Press the pedal (2, fig.13) to rotate the turntable

and press the button  to activate lower bead breaker penetration (Fig. 46).

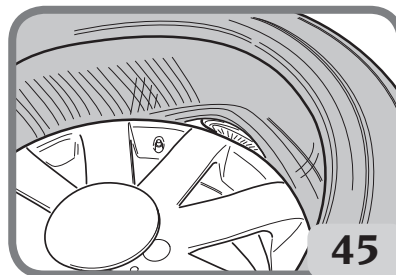
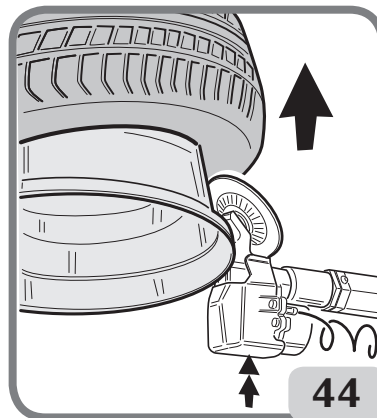
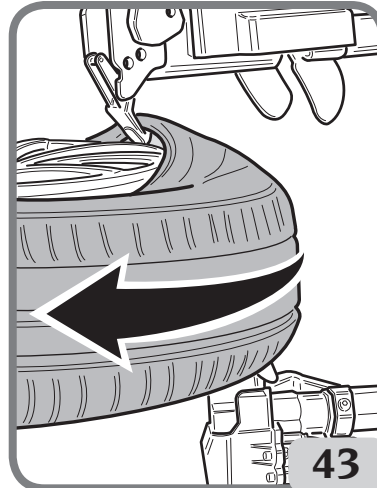
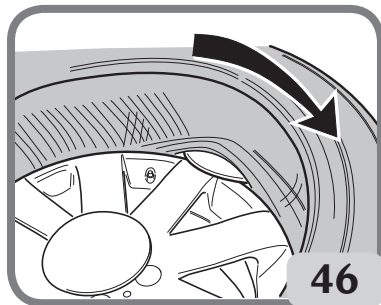

- If necessary, use the control  to raise the lower the bead breaker disc slightly and bring the bead completely out of the wheel.

EN

6.8. MOUNTING

CAUTION!

Always check that the tyre/rim combination is correct in terms of compatibility (tubeless tyre on tubeless rim; tube type tyre on tube type rim) and geometrical size (keying diameter, cross-section width, off-set and shoulder profile) before mounting.

Also check that rims are not deformed, that their fixing holes have not become oval, that they are not encrusted or rusty and that they do not have sharp burrs on the valve holes. Check that the tyre is in good condition with no signs of damage.

- 1 - Lubricate the sides of the tyre thoroughly along the entire circumference of the bottom and top beads (Fig. 47).



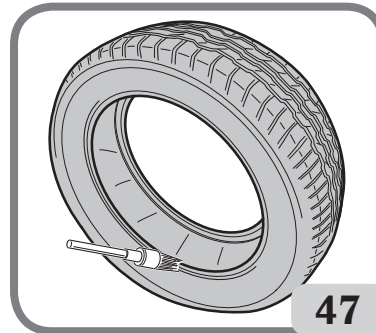

- 2 - Operate the control  to move the lower bead breaker disc out of the work area.

- 3 - Manually adjust the tyre so that the upper shoulder of the rim passes the lower bead and goes into the well.



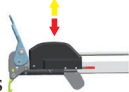

- 4 - Pull the knob (1, Fig. 48) and manually lower the mounting tool, ensuring that it engages correctly in the lower fulcrum position.

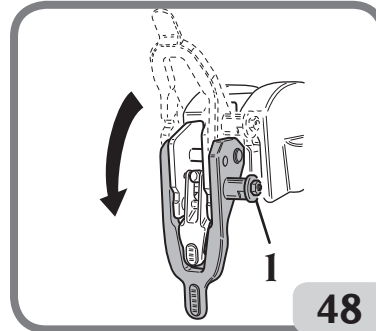

- 5 - Move the lever downwards  to apply pressure to the tyre.

- 6 - Keep the portion of tyre with the lower bead still not inserted in the wheel rim partially depressed, and turn the turntable until the first bead is completely seated (fig. 49).



- 7 - Move the lever  down to bring the mounting tool into the position shown in figure 50.

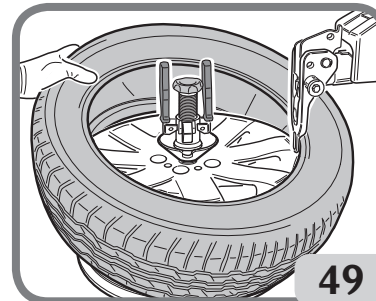

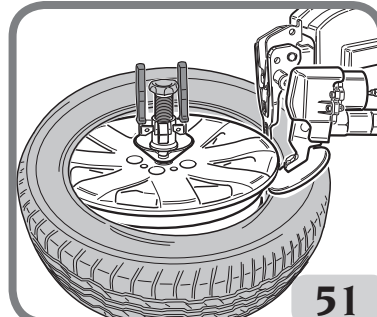
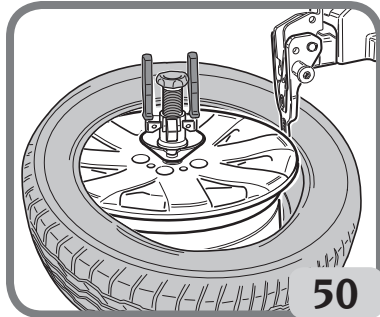

8 - Operate the lever  to lower the upper bead breaker disc to the level of the wheel rim well and position the tyre correctly (fig.51), and then press the button to activate upper disc penetration.

9- Push the tyre below the level of the shoulder.

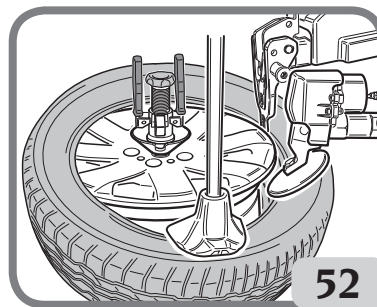

10 - Use the bead depressor tool (Fig. 52) and, if necessary, the bead depressor pliers, applied to the shoulder of the wheel rim, ensuring that the upper bead is in the well.

CAUTION!

Avoid Personal Injury. Ensure that the top bead is held correctly by the tool before mounting.

EN

11- Press the pedal (2, fig.13) to activate rotation until the second bead is mounted (Fig. 53).

12- Remove the bead pressing pliers or the bead pressing tool.

13- Return the bead breakers on the upper and lower sides to the rest positions.

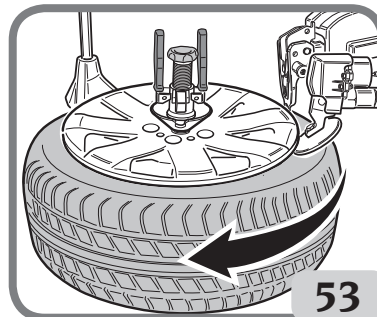

CAUTION!

Avoid personal injury. Make sure the top bead is correctly inserted in the rim well, throughout the mounting stage.

14 - Move the fixed tool out of the work area and return it to its rest position (fig. 54).

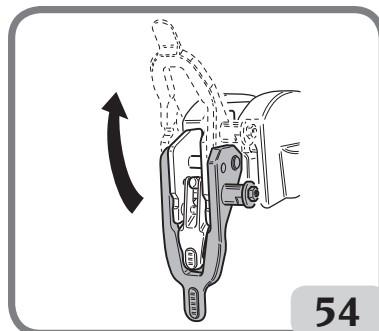

! CAUTION!

Position the bead pressing tool in the correct rest position so that it does not interfere with the work area.

NB: If the tyre is particularly soft, the first bead can be mounted with the mounting tool on the lower bead breaker arm, next to the bead breaker disc.

- remove the pin (fig. 55), rotate the unit (fig. 56) by 90°, refit the pin (fig. 57), and rotate the mounting tool from its rest position to its working position (fig. 58).

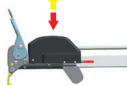
- operate the lever  to raise the mounting tool and bring it close to the upper edge of the wheel (fig. 59)

- manually adjust the position of the tyre so that the upper shoulder of the wheel rim moves past the lower bead and enters the well.

- keep the portion of tyre with the lower bead still

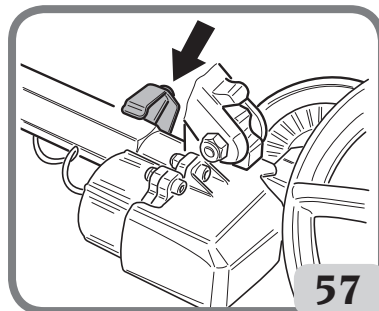
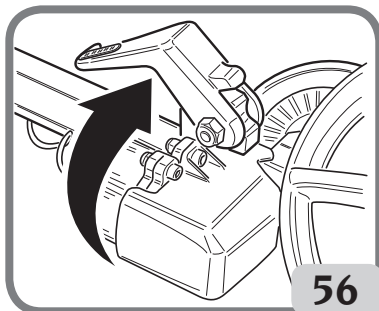
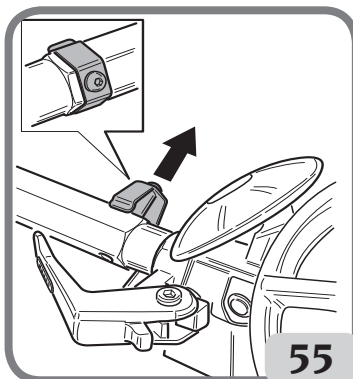

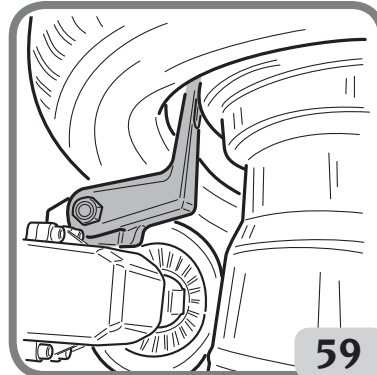
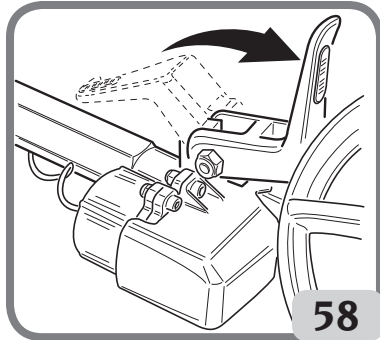

not inserted in the wheel rim partially depressed, and press the pedal (fig. 60) to activate rotation until the first bead is completely inserted (fig. 61).

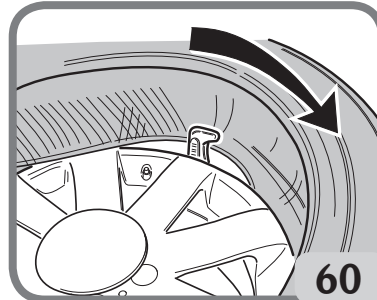

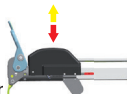
- move the lever  down to move the mounting tool to the rest position.
- use the relative pin to return the lower bead breaking disc to the working position.
- return the demounting tool to the rest position.

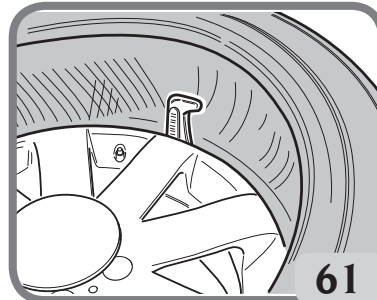

EN

6.9. APPROVED UHP and RUN FLAT TYRE DEMOUNTING AND MOUNTING PROCEDURE

For this type of tyre please refer to the instructions in the manual prepared by WDK (German Tyre Industry Association).

6.10. TYRE INFLATION

6.10.a. SAFETY REGULATIONS

	<p style="text-align: center;"> DANGER</p> <p>RISK OF EXPLOSION Never exceed the pressure recommended by the tyre manufacturer. Never mount tyres on rims with a different diameter. An exploding tyre can cause personal injury or death.</p>
---	---

Check that both the upper and lower beads and the rim bead seat have been suitably lubricated with paste appropriate for mounting.
Safety goggles with plain lenses and safety footwear must be worn.

Lock the rim on the turntable during inflation.

Remove the valve core if it has not already been removed.

Connect the inflation line to the valve
Press the pedal to inflate the tyre and make the beads adhere. Stop frequently to check the internal tyre pressure on the pressure gauge.

<p style="text-align: center;"> CAUTION!</p> <p>Take care to avoid any injuries. Carefully read, understand and observe the following instructions.</p>
--

1. Overinflated tyres can explode, producing hazardous flying debris that may result in an accident.
2. Tires and Rims that are not the same diameter are “mismatched”. Never attempt to mount or inflate any tire and rim that are mismatched. For example, never mount a 16” tire on a 16,5” rim (or vice versa). This is very dangerous. A mismatched tire and rim could explode, and resulting in an accident.
3. Never exceed the inflation pressure for the tyre indicated by the manufacturer on the side of the tyre itself.
Carefully check that the air hose is well inserted in the valve.
4. Never bring your head or other body parts close to a tyre during inflation or bead insertion operations.
This machine is not a safety device against the possible explosion risk of tyres, air chambers or rims.
5. Maintain a suitable distance from the tyre changer while inflating. Do not approach it.

CAUTION!



During this operation, noise levels assessed at 85 dB(A) may occur. Therefore operators are advised to wear hearing protection devices.

DANGER

RISK OF EXPLOSION: The breakage of a pressurised rim or tyre could cause an explosion that projects the wheel to the side or upwards with a force that could cause damage, serious injuries or even death!

Do not mount tyres on rims without first checking the exact correspondence of the dimensions (printed on the rim and tyre) and for the presence of defects or damage.

This tyre changer is NOT a safety device and does not eliminate risks and damage from a possible explosion. Do not permit other people to approach the work area.

6.10.b. TYRE INFLATION

1. Make sure the wheel is securely clamped on the turntable by the centring handle (Fig. 62).
2. Ensure that the tool head, the upper and lower bead breaker units and the bead depressor are out of the work area and, if possible, in the rest position.

3. Remove the valve core if it has not already been removed (Fig. 63).

4. Connect the air hose Doyfe inflator union to the valve stem (Fig. 64).



5. Press the pedal to inflate the tyre at short intervals. Frequently check the pressure on the

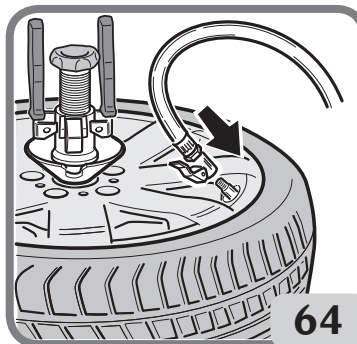
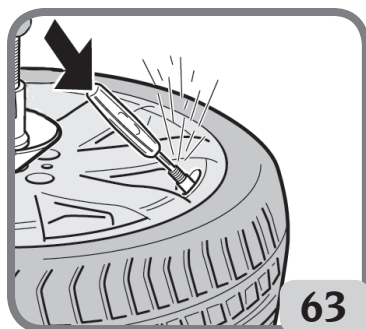
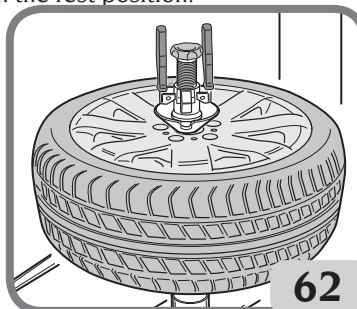

EN

pressure gauge (1, Fig.65) to make sure that the pressure NEVER exceeds the maximum pressure indicated by the manufacturer on the tyre. The tyre widens and the beads are positioned.

If necessary:

6. Continue inflating up to the maximum value of 3.5 bar to position the tyre correctly on the rim. Avoid distractions during this operation, and continually check tyre pressure on the air pressure gauge (1, Fig. 65) to prevent excessive inflation. Inflating tubeless tyres requires a larger air flow to force the beads past the HUMP rim - see rim profiles for mounting tubeless tyres in fig Fig.66.

7. Check that the beads are correctly inserted in the rim; otherwise, deflate the tyre, break the beads as described in the relevant section, lubricate and turn the tyre on the rim. Repeat the mounting operation described previously and check again.

8. Reinsert the internal valve mechanism.

9. Adjust the pressure to the rated inflation value by pressing the deflation button (2, Fig. 65).

10. Fit the cap to the valve.

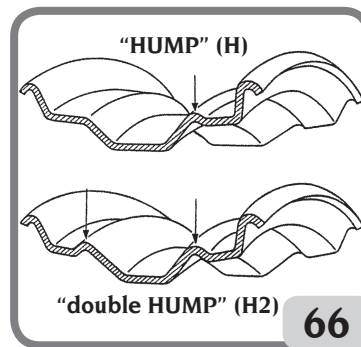
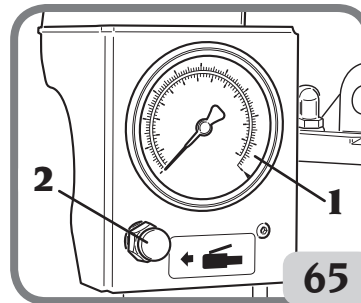

6.10.c. SPECIAL PROCEDURE (TI VERSION)

! CAUTION!

Before starting with the operations described below, make sure there is no dirt, dust or other impurities near the inflation nozzles.

If while inflating the tyre is not positioned correctly on the rim due to excessive space between the tyre and the rim, a jet of pressurised air can be used with the jaw of the optional T.I. accessory (quick bead insertion). Verify that both upper and lower tire beads and rim bead seat have been properly lubricated with an approved mounting paste.

1. Make sure that the rim is correctly clamped on the turntable (Fig. 67).

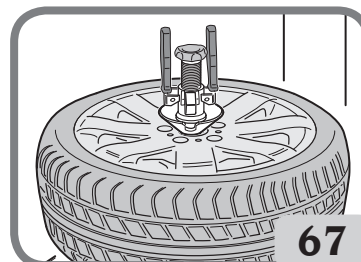

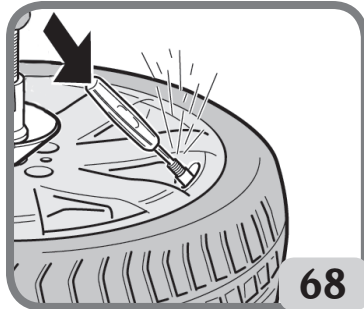

68

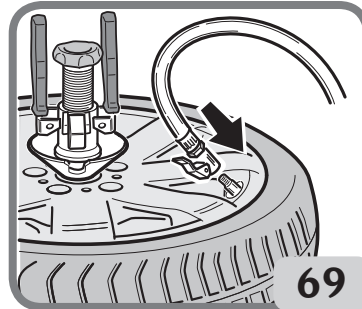

69

2. Remove the valve core if it has not already been removed (Fig. 68).
3. Connect the air hose Doyfe inflator union to the valve stem (Fig. 69).
4. Pull the tyre up slightly to reduce the space between the upper bead and the rim (Fig. 70).



5. Depress the inflation pedal  completely and simultaneously press the two buttons on the accessory to deliver a blast of high pressure air via the four nozzles, which facilitate seating of the tyre beads (Fig. 71).
6. Continue inflating the tyre using the air hose. Frequently stop inflation and check the pressure on the pressure gauge.

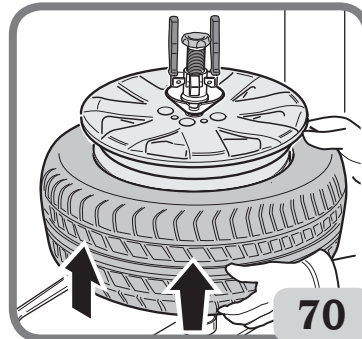

70

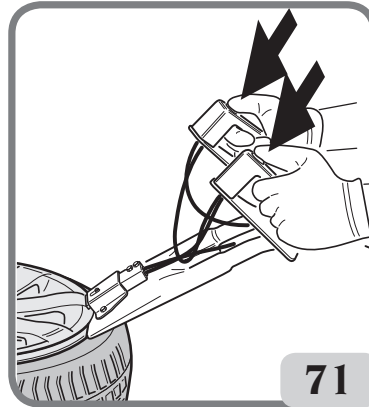

71

EN

CAUTION!

To increase the effectiveness of the air jets, manually lubricate and lift the lower bead before activating the nozzles

CAUTION!

To improve the operation of the tubeless tyre inflation system the line pressure must be between 8 and 10 bar.

! CAUTION!

Risk of explosion. During the bead insertion phase, do not exceed the maximum pressure indicated by the manufacturer on the sidewall of the tyre.

Once the bead has been inserted, refit the internal part of the valve and then inflate the tyre to the pressure indicated by the vehicle manufacturer.

! CAUTION!

Operate the inflation jets only for tyre bead insertion. Do not point jets towards people.

Discharge the air from the pneumatic system before disconnecting the power supply or other pneumatic components. The air is accumulated in the tank for operating the bead insertion jets.

! CAUTION!

Operate the air jets only after making sure that the device is securely in position and the rim is correctly blocked.

! CAUTION!

RISK OF EXPLOSION. Do not mount a tyre and a rim that do not have the same diameter (for example, 16.5 inch tyre and 16 inch rim).

If the tyre is over-inflated, air may be released by pressing the brass manual deflation button located below the air pressure gauge ("2" - Fig.72)

Disconnect the inflation hose from the valve stem.

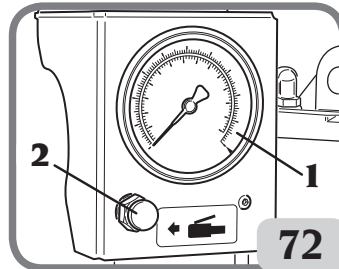

6.11 UNCLAMPING THE WHEEL AND UNLOADING

6.11.a. WHEEL UNCLAMPING

- Loosen the device by turning the handles anticlockwise (Fig. 73).
- Press the retainers "1" and move the centring cone away from the rim by hand (Fig. 73A)

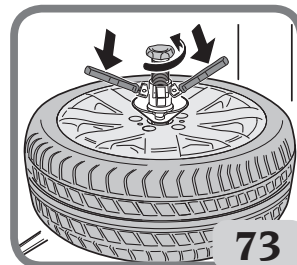

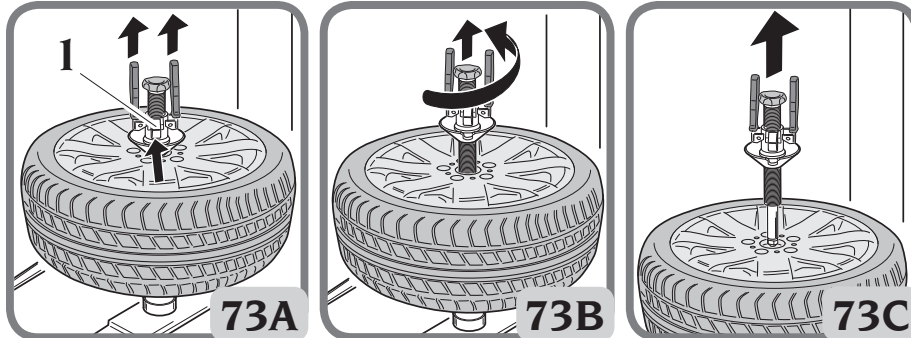

- Turn the clamping device anticlockwise to release it from the turntable (Fig. 73B).
- separate the device from the wheel (Fig. 73C).

6.11.b WHEEL UNLOADING

- Raise the wheel lifter (UP pedal) and load the wheel onto it by hand (Fig. 74).
- Lower the lifter (DOWN pedal) (Fig. 74A).
- Remove the wheel from the lifter

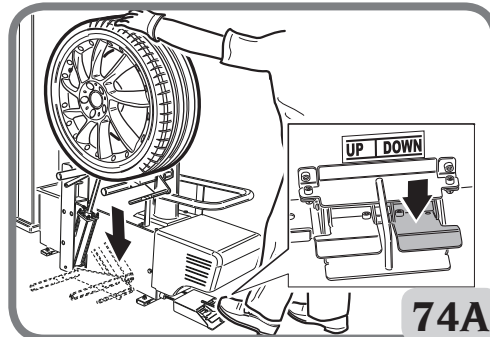
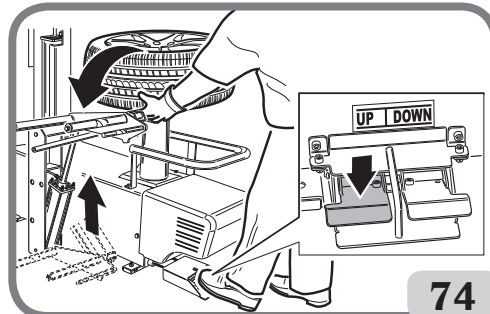

EN

7. MAINTENANCE

DANGER

When the machine is disconnected from the air supply, the devices bearing the sign shown above may remain pressurised.

 **CAUTION!**

The "Spare parts" handbook does not authorise the user to carry out work on the machine with the exception of those operations explicitly described in the User Manual. It only enables the user to provide the technical assistance service with precise information, to minimise delays.

 **CAUTION!**

Do not remove or change any part of the machine (except for maintenance purposes).

 **CAUTION!**

It is prohibited to perform any operation that changes the pre-established value of the pressure regular valve or pressure limiter. The manufacturer declines all liability for damage resulting from tampering with these valves.

 **CAUTION!**

Before making any change or performing maintenance, disconnect the machine's power and air supplies and ensure that all moving parts are suitably blocked.

 **WARNING**

Keep the working area clean. Do not use compressed air, jets of water or thinner to remove dirt or residuals from the machine. While cleaning, try as far as possible to prevent dust from forming or rising.

CAUTION!

CORGHI declines all liability for claims derived from the use of non-original spare parts or accessories.

Scheduled maintenance:

CAUTION!

The machine will periodically prompt maintenance to carry out. Failure to observe instructions could affect proper functioning of the machine.

- Make sure the condensation is draining from the filter-regulator unit:

The regulating filter unit is equipped with a semiautomatic device to drain the condensate. This device is automatically activated whenever pneumatic supply to the machine is cut off. Drain the condensate manually (1, Fig. 75) when the level exceeds level 2, Fig. 75.

Perform every month.

- Clean and lubricate the tool head carriage guide (1, Fig.76):

Clean with environmentally-friendly solvents and lubricate with LIPLEX EP 2 lubricant or equivalent.

To carry out every two months

- Clean and lubricate the bead breaker sliding panel (1, Fig.77):

Clean with environmentally-friendly solvents and lubricate with PTFE synthetic oil or equivalent product.

To carry out every two months

- Clean and lubricate the lower bead breaking unit pin (1, Fig. 78) and the lower bead breaking unit coupling pin (2, Fig. 78):

Clean with environmentally-friendly solvents and lubricate with ordinary grease.

To carry out every month

- Contact the service network to check the belts and rubber pads:

Periodic check by the service network.

To carry out every 7000 wheels

- Clean the upper part of the turntable (Fig 79):

Remove accumulated dirt with environmentally-friendly solvents.

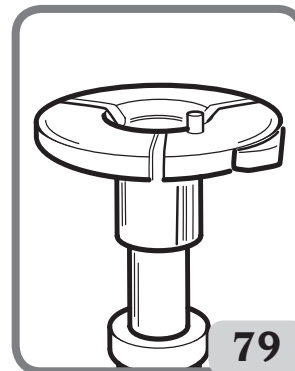
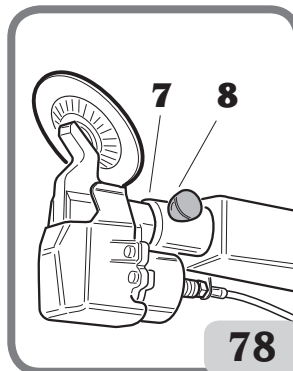
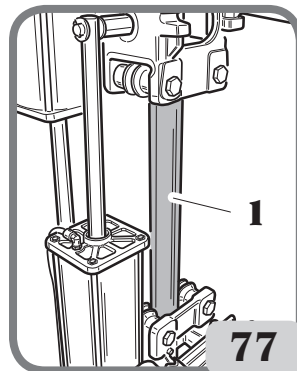
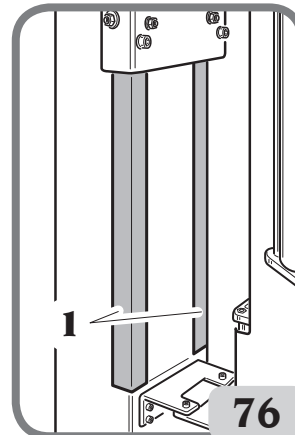
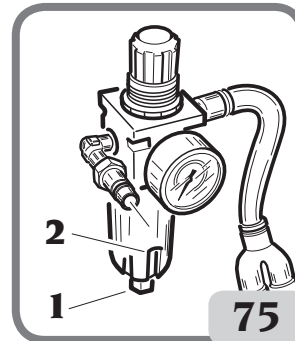

EN

Perform once every week

- **General machine check, contact the service network:**

General periodic check by the service network.

To carry out every year

8. INFORMATION ABOUT SCRAPPING

If the machine is to be scrapped, remove all electrical, electronic, plastic and metal parts
Dispose of them separately, as provided for by local regulations in force.

9. ENVIRONMENTAL INFORMATION

The disposal procedure described below only applies to machines with the symbol of



the waste bin with a bar across it  on their data plates.

This product may contain substances that can be hazardous to the environment and to human health if it is not disposed of properly.

We therefore provide you with the following information to prevent releases of these substances and to improve the use of natural resources.

Electrical and electronic equipment should never be disposed of in the usual municipal waste but must be separately collected for their proper treatment. The crossed-out bin symbol, placed on the product and on this page, reminds the user that the product must be disposed of properly at the end of its life.

This prevents the inappropriate disposal of the substances which this product contains, or the improper use of some of them, from having hazardous consequences for the environment and human health. Furthermore, this helps to recover, recycle and reuse many of the materials contained in these products.

To this end, electrical and electronic manufacturers and distributors have set up proper collection and treatment systems for these products.

At the end of the product's working life, contact your supplier for information about disposal procedures. When you purchase this product, your supplier will also inform you that you may return another worn-out appliance to him free of charge, provided it is of the same type and has provided the same functions as the product just purchased.

Anyone disposing of the product otherwise than as described above will be liable to prosecution under the legislation of the country where the product is scrapped.

We also recommend you to adopt more measures for environment protection: recycling of the internal and external packaging of the product and proper disposal of used batteries (only if contained in the product).

With your help it is possible to reduce the amount of natural resources used to produce electrical and electronic equipment, to minimise the use of landfills for the disposal of the products and to improve the quality of life by preventing that potentially hazardous substances are released in the environment.

10. INFORMATION AND WARNINGS ABOUT OIL

Disposing of spent fluid

Do not dispose of used oil into sewage mains, storm drains, rivers or streams. collect it and consign it to an authorised disposal company.

Fluid leaks or spills

Contain the spilt product from spreading using soil, sand or any other absorbent material. Degrease the contaminated area with solvents, taking care to disperse the fumes. The residual cleaning material must be disposed of as prescribed by law.

Precautions for the use of hydraulic fluid

- Avoid contact with skin.
- Avoid formation and spreading of oil mists into the atmosphere.
- Adopt the following simple sanitary precautions:
 - protect against oil splashes (appropriate clothing, protective guards on machines);
 - wash frequently with soap and water; do not use cleaners or solvents that can irritate your skin or remove its natural protective oil;
 - do not dry hands with dirty or greasy rags;
 - change clothing if impregnated with oil, and in any case at the end of each work shift;
 - do not smoke or eat with greasy hands.
- Also use the following preventive and protective equipment:
 - gloves resistant to mineral oils, with lining;
 - goggles, in case of splashes;
 - aprons resistant to mineral oils;
 - screens to protect against oil splashes.

Mineral oil: first aid indications

- Swallowing: seek medical attention, providing the characteristics of the type of oil swallowed.
- Inhalation: in case of exposure to high concentrations of fumes or mists, take the injured person to the open air and seek medical attention immediately.
- Eyes: rinse with plenty of running water and seek medical attention as soon as possible.
- Skin: wash with soap and water.

EN

11. INFORMATION AND WARNINGS ABOUT TYRE LUBRICATING FLUID

Disposing of spent fluid

Do not dispose of used lubricant fluids in sewers, storm drains, rivers or streams; collect it and consign it to an authorised disposal company.

Lubricant fluid leaks or spills

Avoid product leaks from spreading by using non-inflammable absorbent materials such as dirt, sand, vermiculite or diatomaceous earth.

Clean the contaminated area preferably with a detergent, do not use solvents.

Precautions for the use of lubricant fluid for tyres

- Avoid sprays or contact with the skin.
- Avoid sprays or contact with eyes.
- Do not inhale the fumes.
- Adopt the following simple sanitary precautions:
 - protect skin and eyes against lubricating fluid splashes (appropriate gloves, goggles);
 - in case of contact with skin, wash immediately with plenty of water;
 - in case of contact with eyes, rinse immediately with plenty of water and seek medical advice;
 - if swallowed, seek medical advice and show the label;
 - do not dry hands with dirty rags;
 - change your clothes if they are soaked in lubricating fluid;
 - do not smoke or eat with hands soiled with lubricating fluid.

12. RECOMMENDED FIRE EXTINGUISHING EQUIPMENT

For guidance on the most suitable type of extinguisher, refer to the table below:

	Dry materials	Flammable liquids	Electrical equipment
Water	YES	NO	NO
Foam	YES	YES	NO
Powder	YES*	YES	YES
CO ₂	YES*	YES	YES
YES*	<i>Use only if more appropriate extinguishers are not at hand or when the fire is small.</i>		

WARNING

The indications given in this table are of a general nature and should be used as a general guide. All the applications of each type of extinguisher must be obtained from the relevant manufacturer.

13. GLOSSARY

Tyre

A tyre consists of: **I-the tyre**, **II- the rim (wheel)**, **III-the inner tube** (in tube type tyres), **IV-pressurised air**.

The tyre must:

- withstand a load,
- ensure driving power,
- steer the vehicle,
- aid handling and braking,
- aid vehicle suspension.

I - Tyre The tyre is the main part of the complex that is in contact with the road and is therefore designed to support the internal air pressure and all other stress arising from use.

A tyre section shows the various parts it consists of:

1 - *The tread*. It is the part in contact with the road while the tyre is rolling. It comprises a rubber compound and a "pattern" suitable for ensuring good resistance to abrasion and good grip in dry and wet conditions, as well as quiet operating conditions.

2 - *Edge or bracing*. This is a metal fabric or textile insert, in the area of the outer bead part It protects the casing plies from rubbing against the rim.

3 - *Casing*. This is the resistant structure and comprises one or more layers of rubber plies. The way the plies comprising the casing are arranged give the structure its name. The following structures are possible:

Conventional: the plies are inclined and arranged so that the strands comprising a ply overlap with those of the adjacent ply. The tread, which is the part of the tyre in contact with the ground, is part of the sidewalls and so during rolling, sidewall flexure is transmitted to the tread.

Radial The casing consists of one or more plies with the cords in a radial direction.

A radial casing in itself is quite unstable. To make it stable and prevent incorrect tread movement in the area of contact with the ground, the casing and the tread are reinforced with an annular structure, usually called a belt. The tread and sidewall work with different, independent rigidities, so during roll-

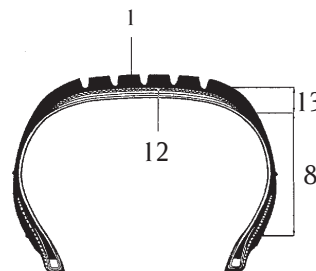
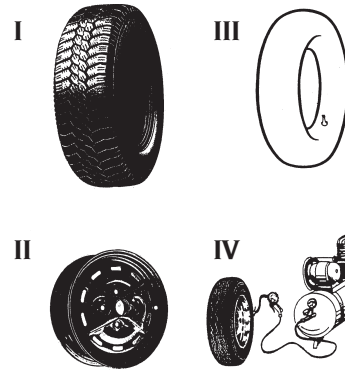

EN

ing, sidewall flexure is not transmitted to the tread.

4 - *Side ring* This is a metal ring with various steel wires. The casing plies are secured to the side ring.

5 - *Belt*. This is a non-flexible circumferential structure comprising cross-plyies at very low angles, positioned below the tread, to stabilise the casing in the footprint area.

6 - *Centring band*. This is a small marking which indicates the circumference of the top part of the bead and is used as a reference to check exact tyre centring on the rim after mounting.

7 - *Protective band*. This is a circumferential marking in the area of the sidewall which is more exposed to accidental rubbing.

8 - *Sidewall*. This is the area between the shoulder and the centring band. It consists of a more or less thin layer of rubber, which protects the casing plies from lateral impact.

9 - *Liner* This is a vulcanised, compound layer, impermeable to air, inside tubeless tyres.

10 - *Filling* This is a generally triangular rubber profile, above the side ring; it provides rigidity for the bead and gradually offsets the abrupt uneven thickness caused by the side ring.

11 - *Flap*. This is the part of the casing ply around the side ring and placed against the casing, to secure the ply and prevent it from slipping.

12 - *Foot*. This is the innermost layer of the tread in contact with the belt, or if the latter is not present (conventional tyres) with the last casing ply.

13 - *Shoulder* This is the most external part of the tread, located between the corner and the start of the sidewall.

14 - *Bead*. This is the part that joins the tyre to the rim. The bead point (a) is the inner corner. The spur (b) is the inner part of the bead. The base (c) is the area resting against the rim. The groove (d) is the concave part against which the rim shoulder rests.

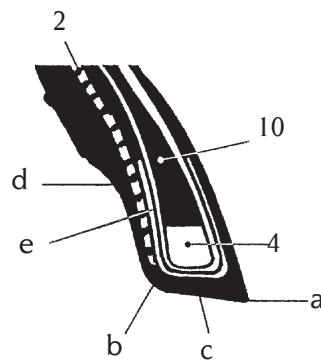
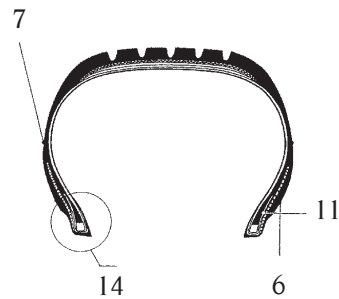
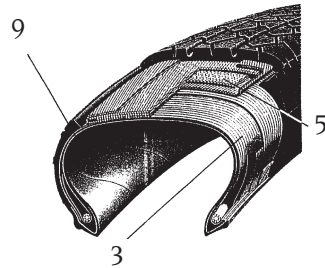

Tube type tyres. As a tyre has to contain pressurised air for a long period of time, an air chamber is used. The valve for adding air and maintaining, controlling and restoring air pressure is part of the chamber in this case.

Tubeless tyres. Tubeless tyres consist of a tyre with inner sidewall lined with a thin layer of special impermeable rubber, called *liner*. This liner helps to maintain air pressure in the casing. This kind of tyre must be mounted on a specific rim, to which the valve is directly fixed.

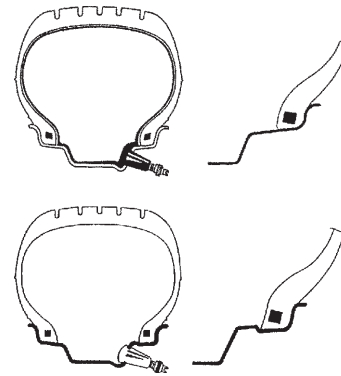

II - Rim (Wheel). The wheel is the rigid metal part which connects the vehicle hub to the tyre, on a fixed but non-permanent basis.

Rim profile. The rim profile is the form of the section in contact with the tyre. It comprises different geometric forms, which ensure: easy tyre mounting (bead insertion in the rim well); safe driving, in terms of the bead anchored in its seat.

The rim section shows its various parts: a) rim width – b) shoulder height – c) tubeless anchoring (HUMP) – d) valve hole – e) ventilation opening – f) off set – g) central hole diameter – h) attachment hole centre to centre i) keying diameter – j) rim well.

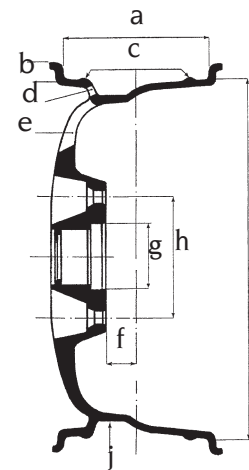

III - Air chamber (tube type tyres). The air chamber is a closed ring-like rubber structure with a valve, which contains pressurised air.

Valve. The valve is a mechanical device to inflate/deflate the tyre and maintain air pressure inside the air chamber (or tyre in the case of tubeless tyres). It consists of three parts: the valve closing cap (a) (to protect the internal mechanism from dust and guarantee air tightness), an internal mechanism (b) and the base (c) (the outer lining).

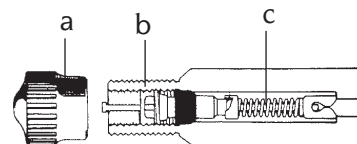

Tubeless Inflator. An inflation system which simplifies inflating tubeless tyres.

Beading. Operation which takes place during inflation and ensures perfect centring between the bead and the rim edge.

Bead pressing gripper. A tool intended for use when

mounting the upper bead. It is positioned so that it engages the shoulder of the rim and maintains the upper tyre bead inside the well. It is generally used for mounting low profile tyres.

Air delivery regulator. Union allowing regulation of the air flow.

Bead breaking. Operation that allows the tyre bead to be detached from the rim edge.

TABLE FOR USING CENTRING AND CLAMPING ACCESSORIES ACCORDING TO RIM TYPE

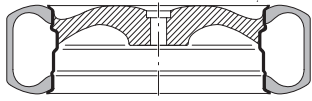
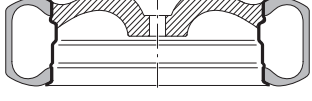
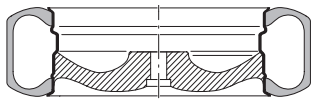
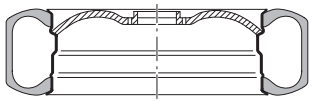
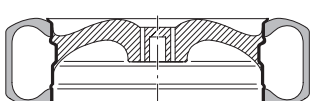
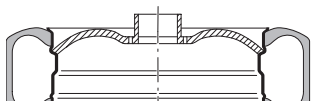
	<p>A Standard rim</p>
	<p>B Dropped centre hole rim</p>
	<p>C Reversed rim</p>
	<p>D Pick-up rim</p>
	<p>E Rim without central hole</p>
	<p>F Open centre rim</p>

EN

CLAMPING ACCESSORIES

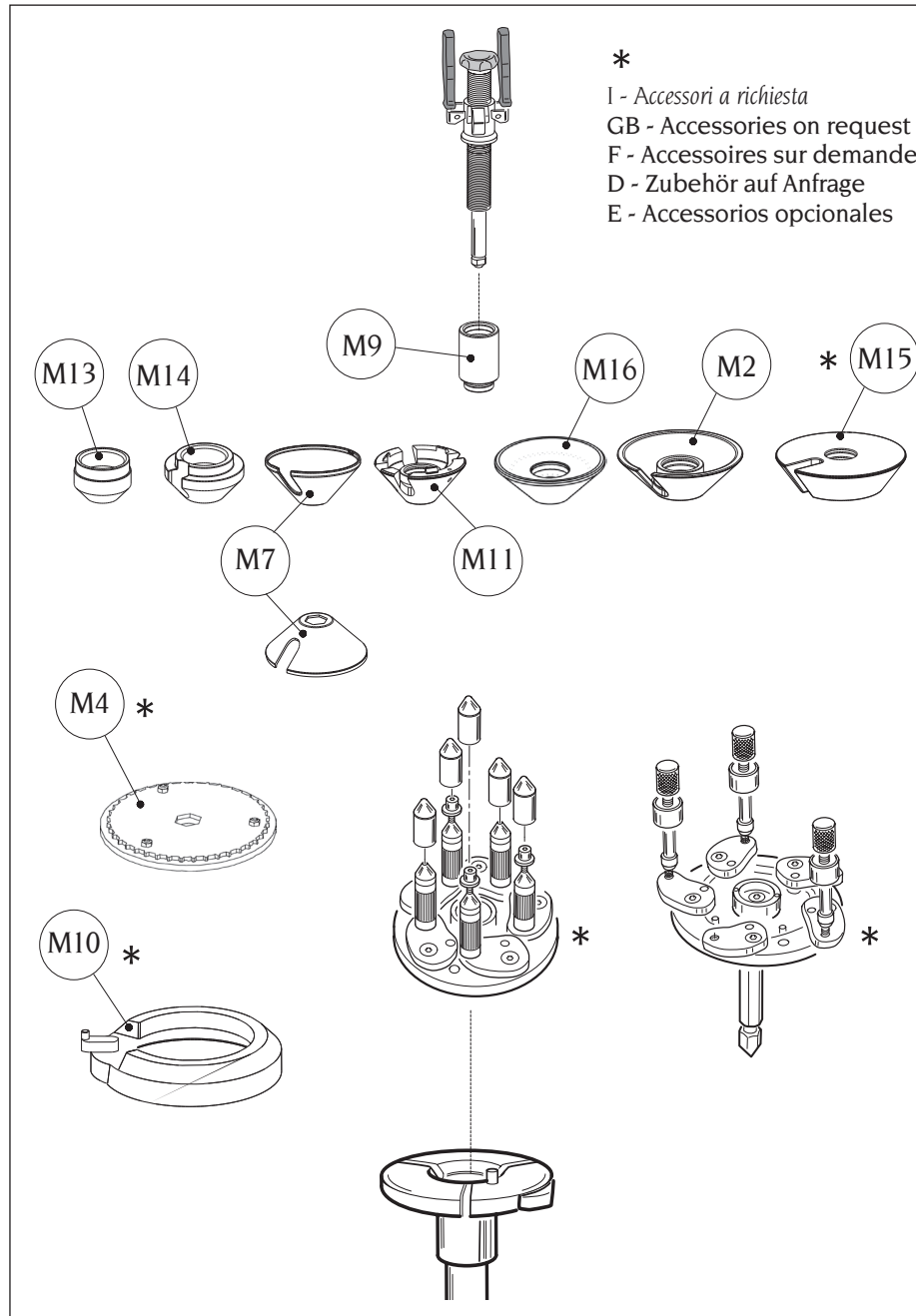

STANDARD RIM

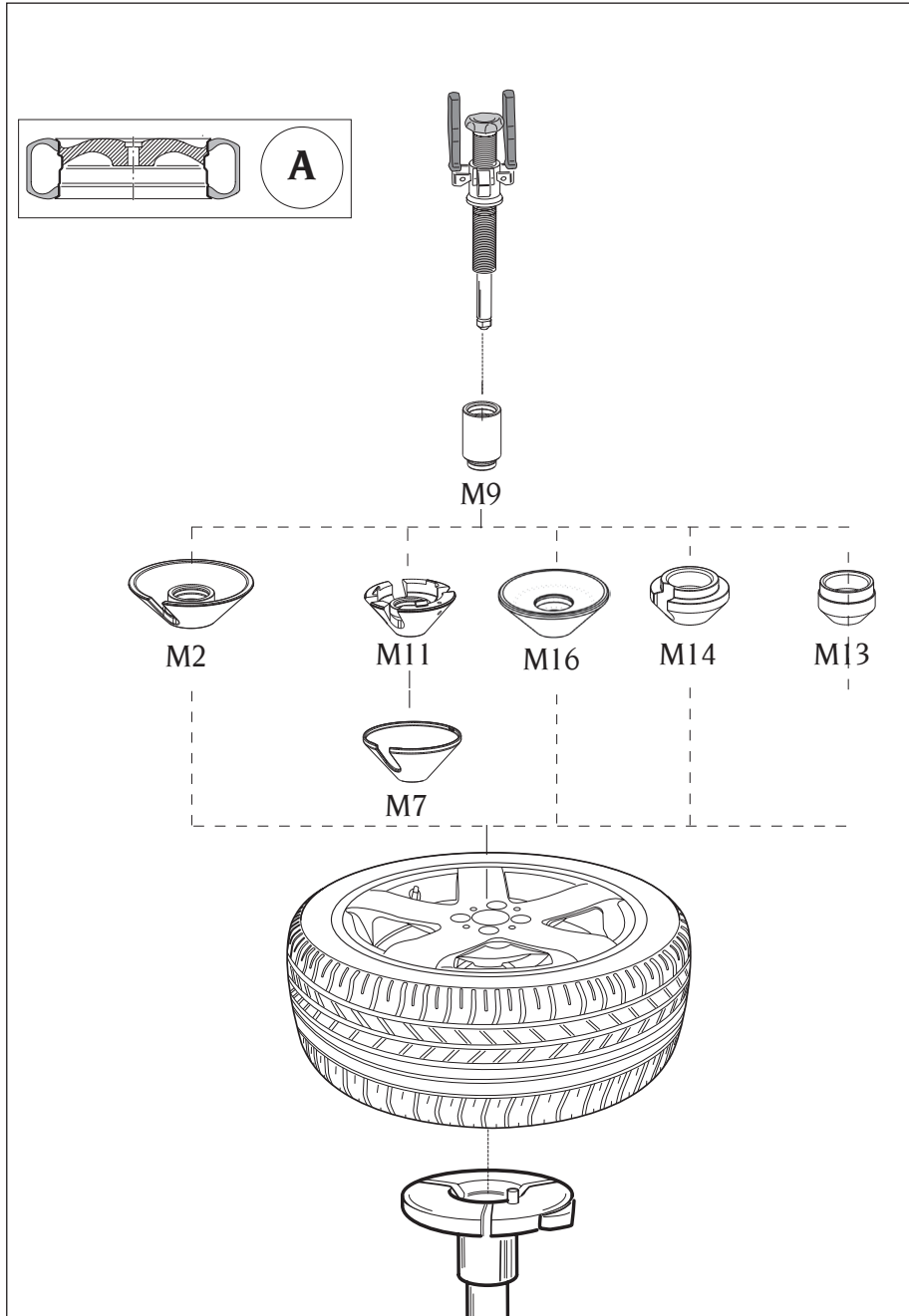

EN

DROPPED CENTRE HOLE RIM

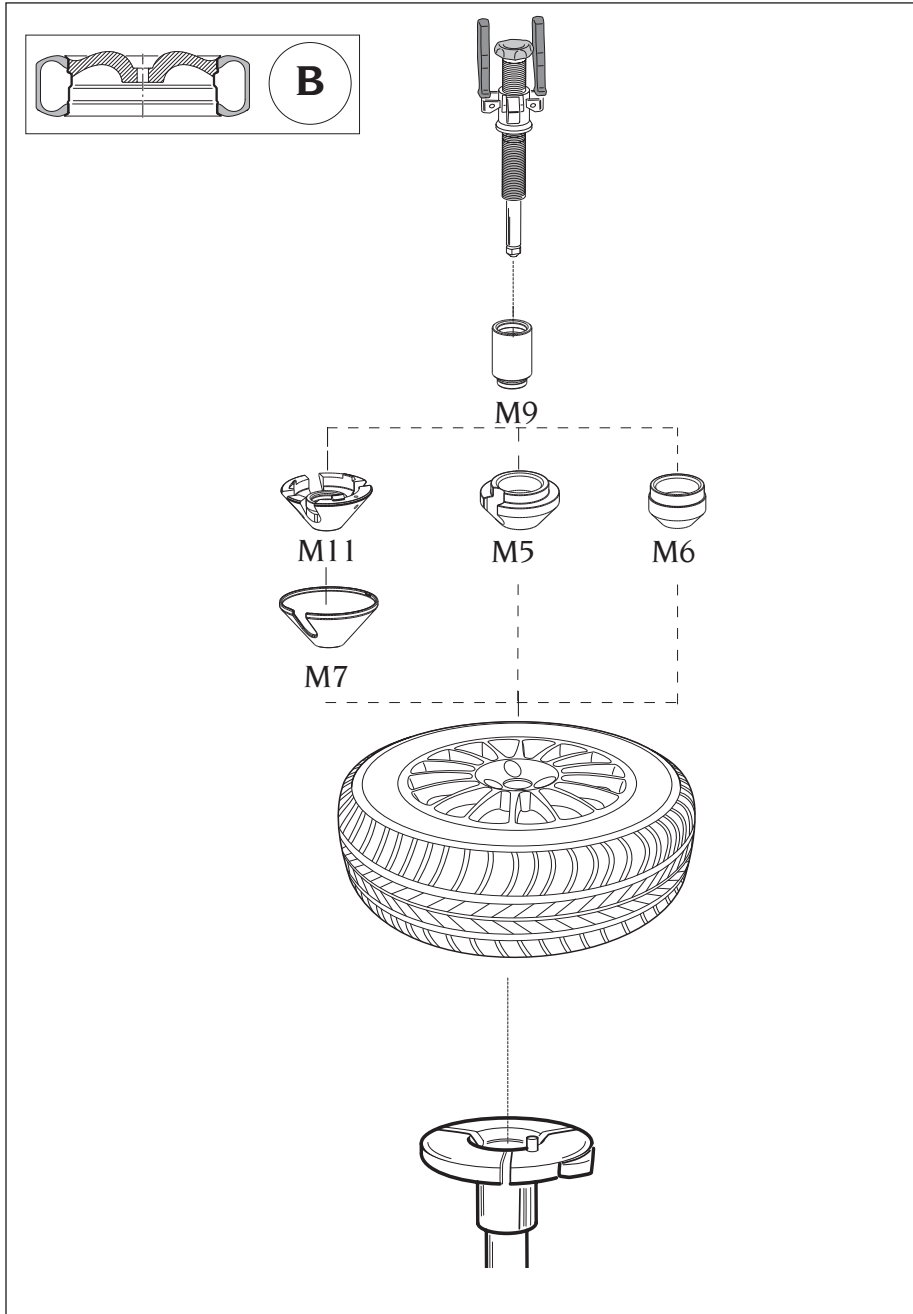

REVERSED RIM

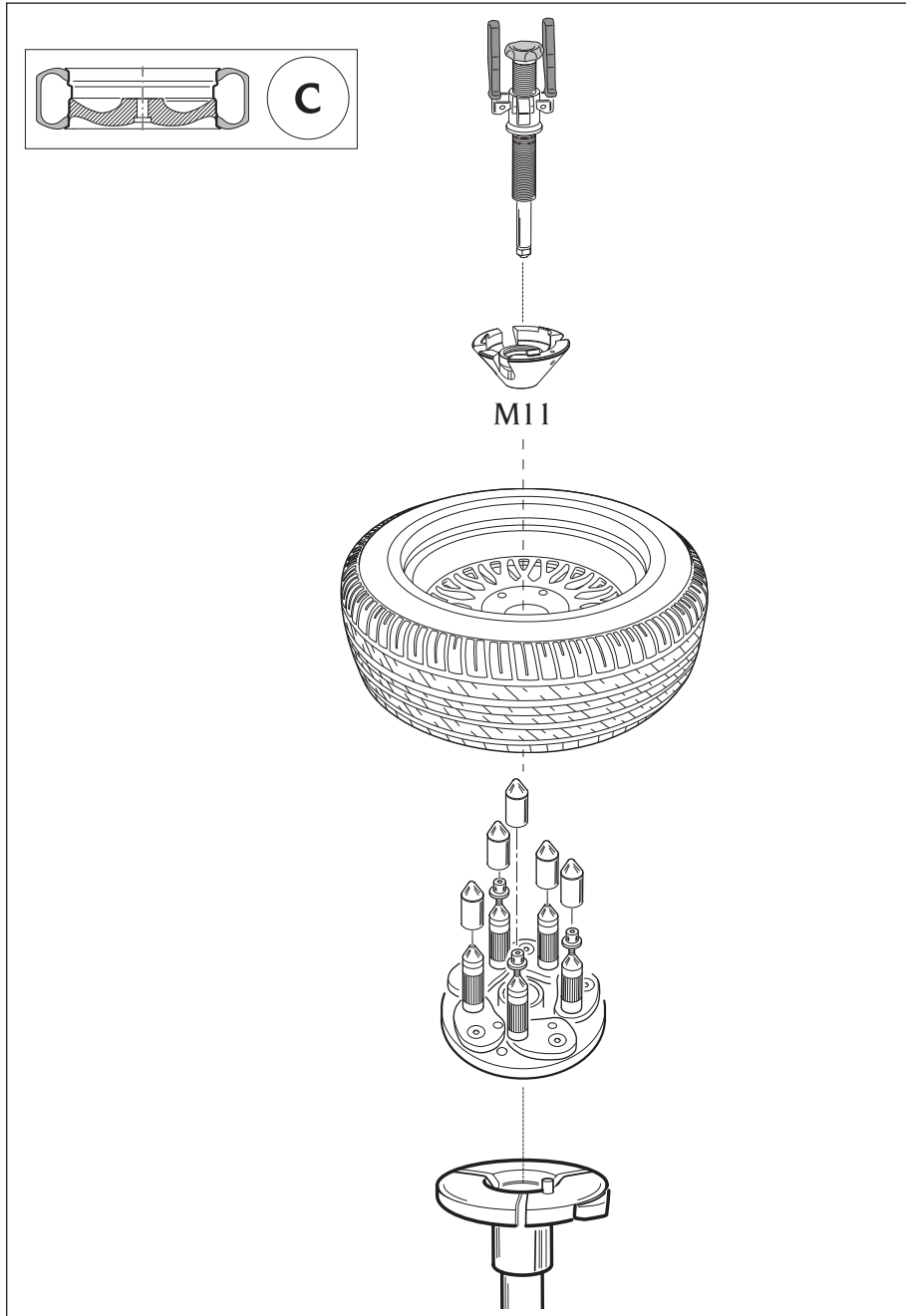

EN

PICK-UP RIM

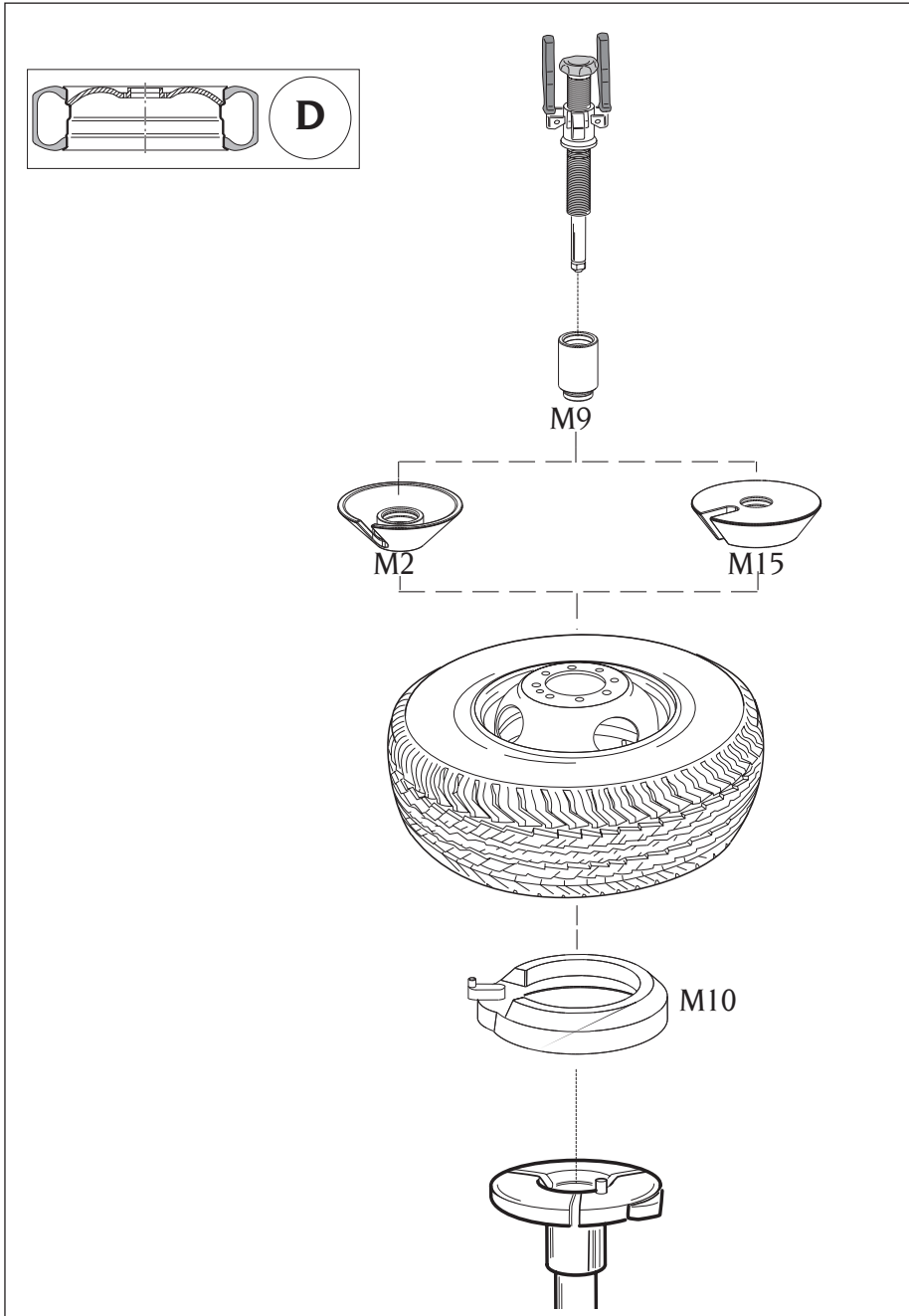

RIMS WITHOUT CENTRAL HOLE

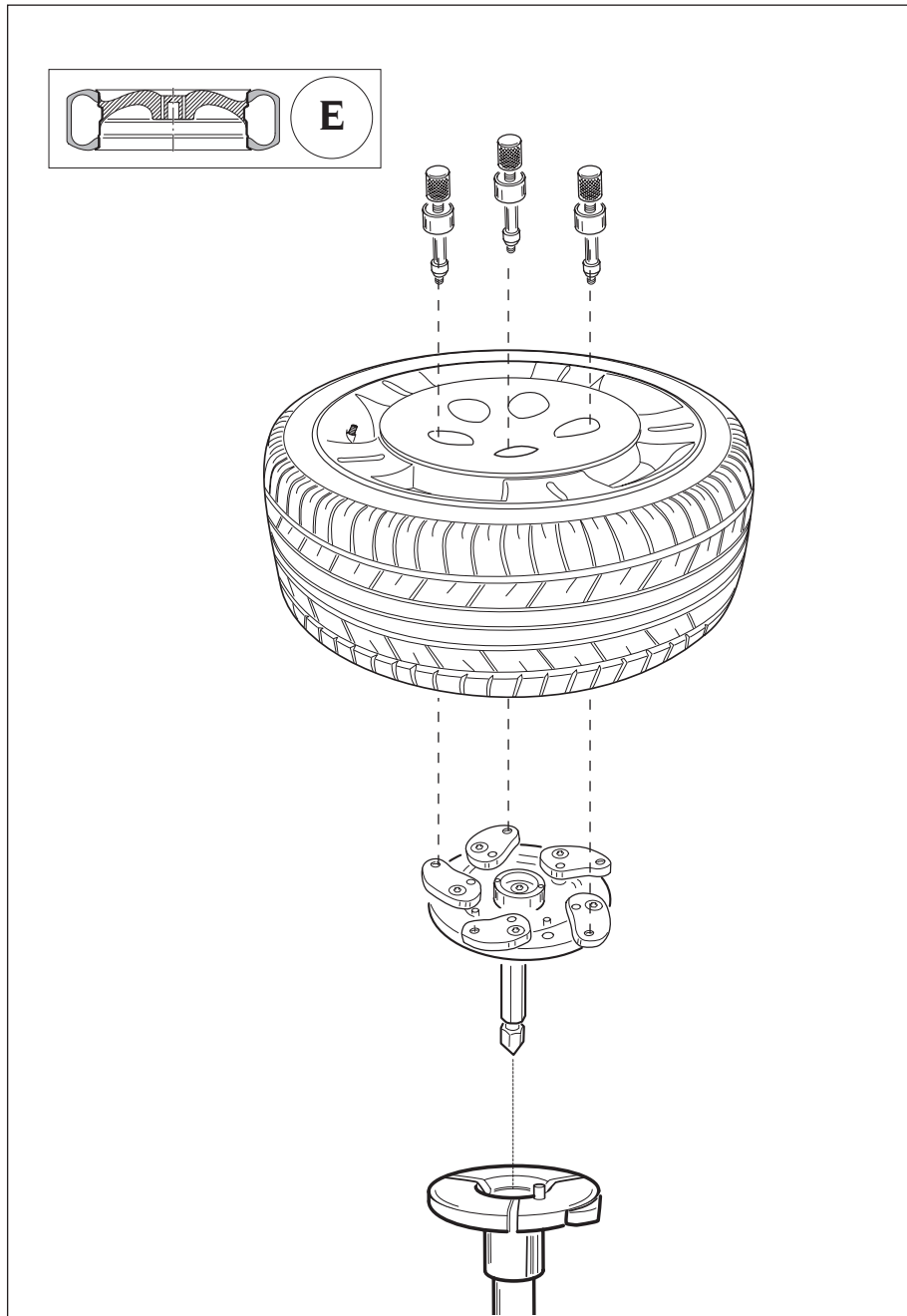

EN

OPEN CENTRE RIM

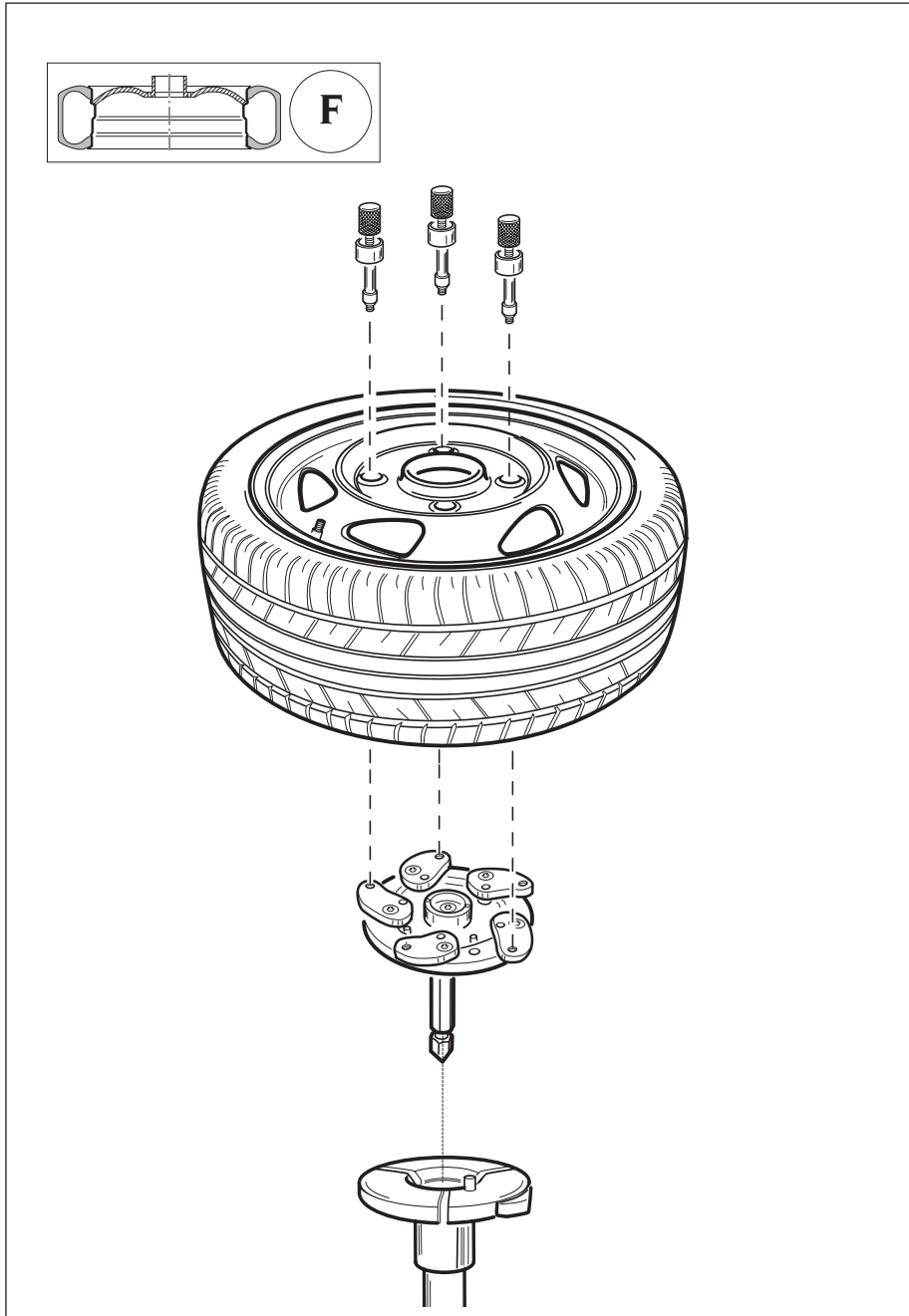

WIRING DIAGRAM

- AP1 Single / two-speed motor circuit board
- M1 Motor
- SQ1 Two-speed micro-switch
- SQ2 Micro-switch (ANTICLOCKWISE rotation)
- SQ3 Micro-switch (ANTICLOCKWISE rotation)
- XB1 Connector
- XS1 Power supply plug

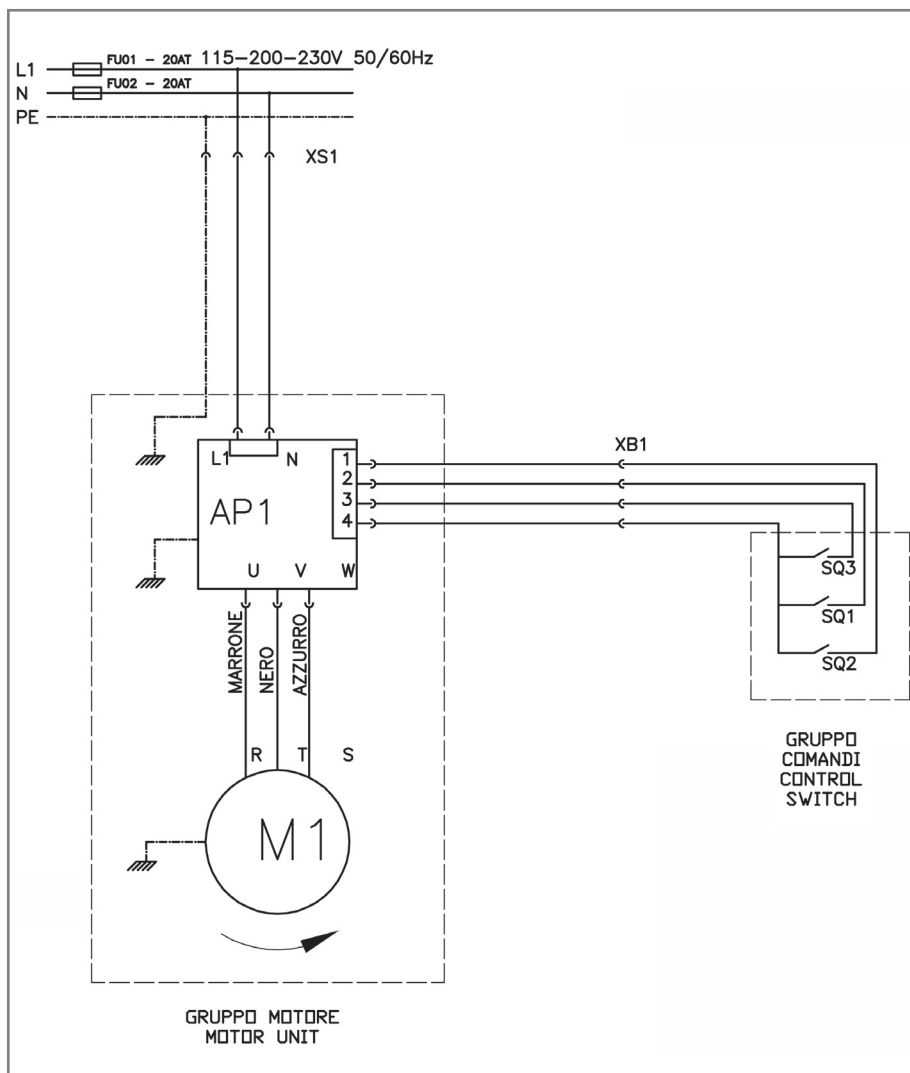

EN

PNEUMATIC DIAGRAM

A FILTER REGULATOR UNIT

- 1 Female quick connector
- 2 Filter regulator unit
- 3 Lubricator
- 4 Pressure gauge
- 5 Pedal unit inflation pressure limiter

B PENETRATION AND BEAD BREAKER CYLINDER CONTROL

- 10 Monostable upper disc pneumatic reset button (3/2 NC valve)
- 11 Upper disc penetration single-acting cylinder
- 12 Lever control (5/3 CC valve)
- 13 Double acting upper bead breaker cylinder d. 110 mm
- 14 Monostable button
- 15 Lower disc penetration single-acting cylinder
- 16 Lever control (5/3 CC valve)
- 17 Double acting lower bead breaker cylinder d. 110 mm

C – BEAD BREAKER MOVEMENT CYLINDER CONTROL

- 20 3/2 NO monostable lever valve
- 21 Upper and lower grip single acting cylinder
- 22 Lever control (5/3 CC valve)
- 23 2/2 NO pneumatic control monostable valve
- 24 Double acting cylinder d. 40 mm

D DEMOUNTING TOOL HEAD MOVEMENT

- 30 3/2 NO search valve
- 31 3/2 NC demount valve
- 32 Tool head actuator cylinder

E HORIZONTAL HEAD MOVEMENT

- 40 3/2 NO monostable lever valve
- 41 Upper and lower grip single acting cylinder
- 42 Lever control (5/3 CC valve)
- 43 2/2 NO pneumatic control monostable valve
- 44 Double acting cylinder d. 40 mm

F VERTICAL HEAD MOVEMENT

- 50 Silencer filter
- 51 5/3 NC valve
- 52 Head vertical movement cylinder

H LIFTER (optional)

- 60 5/3 NC valve
- 61 Lifter cylinder

I PEDAL UNIT

70 3/2 NC valve

L BEAD DEPRESSOR

80 Silencer filter

81 5/3 NC valve

82 Bead pressing tool cylinder

M INFLATION**N MANUAL DEFLATION**

90- Pressure gauge

91 Manual deflation valve 2/2 NC

O DISTRIBUTOR

100 Distributor

EN

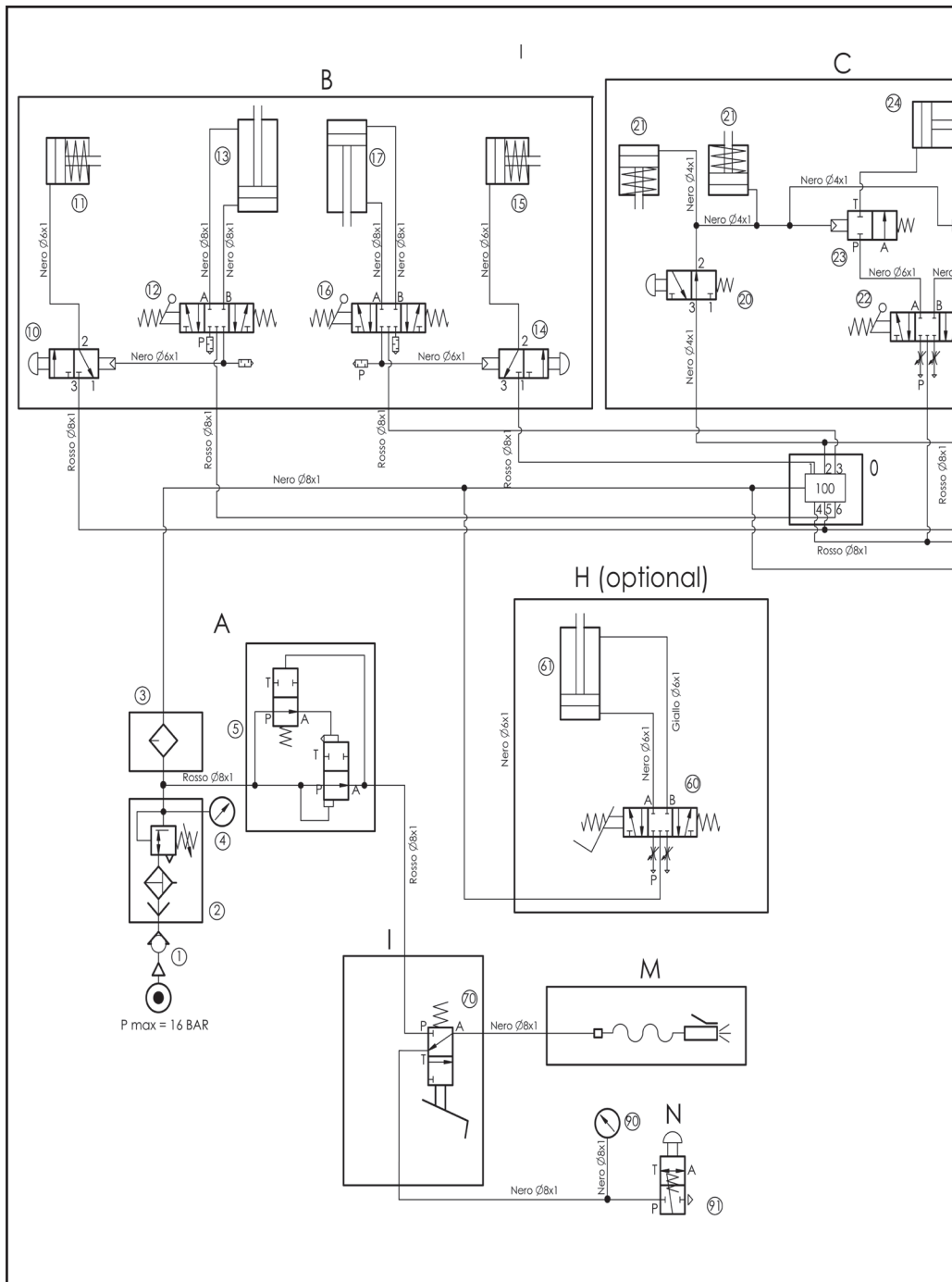

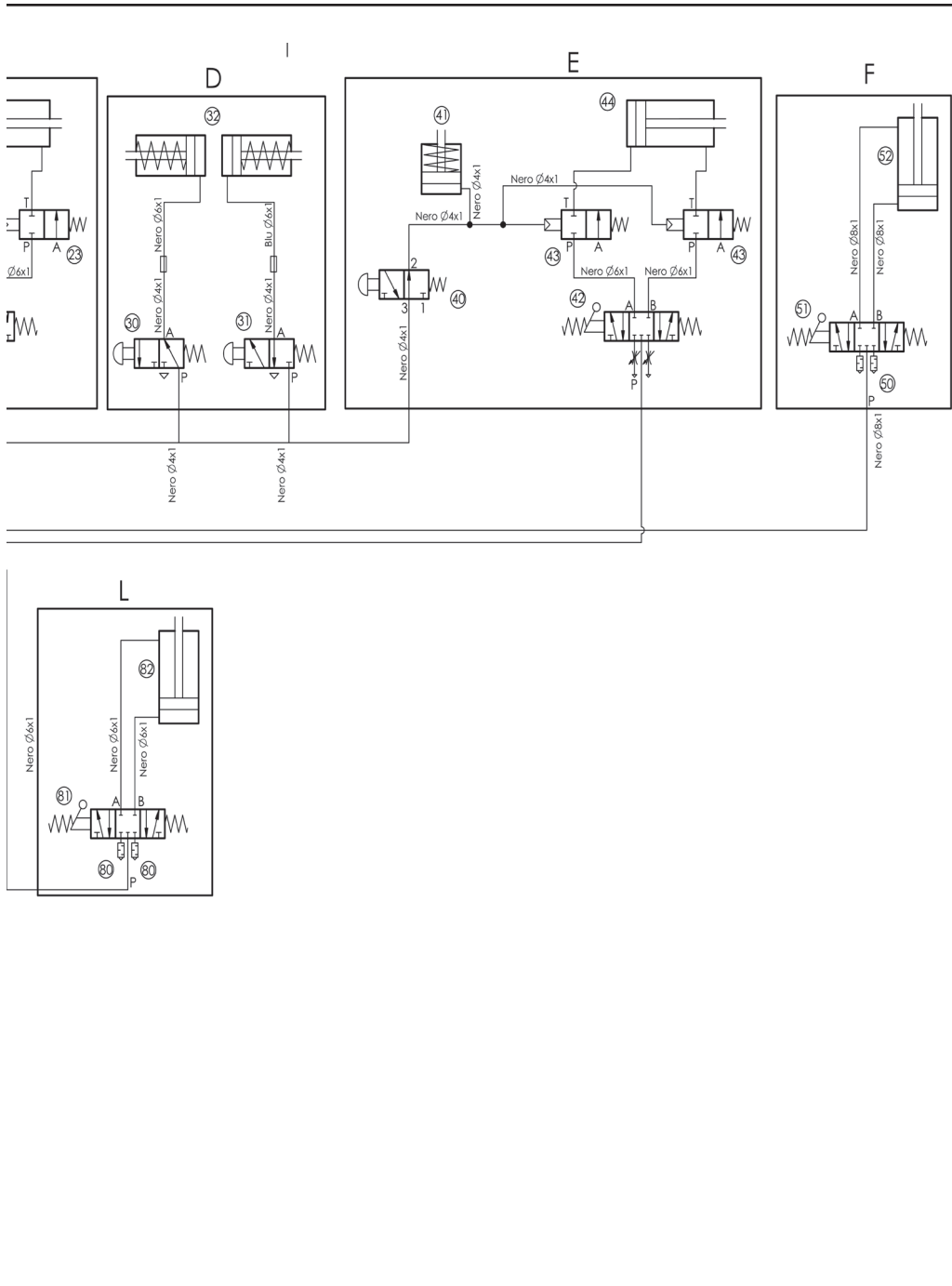

EN

