

COATS®

CWA6500 Model Wheel Aligner

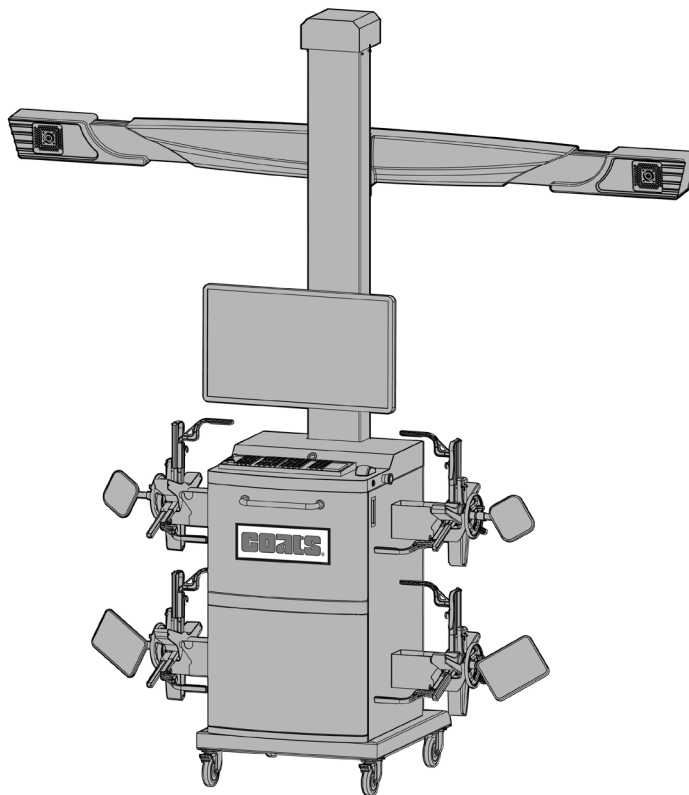

Safety Instructions **Set Up Instructions** **Operation Instructions** **Maintenance Instructions**

READ these instructions before placing unit in service. KEEP these and other materials delivered with the unit in a binder near the machine for ease of reference by supervisors and operators.

HENNESSY
INDUSTRIES

1601 J. P. Hennessy Drive, La Vergne, TN USA 37086 615/641-7533 800/688-6359 www.coatsgarage.com
HENNESSY INDUSTRIES LLC Manufacturer of COATS®, AMMCO® and BADA® Automotive Service Equipment and Tools.

Manual Part No.: 85612055 00
Revision: 10/20



NOTICE

Read entire manual before assembling, installing, operating, or servicing this equipment.

IMPORTANT SAFETY INSTRUCTIONS

READ ALL INSTRUCTIONS

1. Eye and face protection requirements:
“Protective eye and face equipment is required to be used where there is a reasonable probability of injury that can be prevented by the use of such equipment.” O.S.H.A. 1910.133(a) Protective goggles, safety glasses, or a face shield must be provided by the owner and worn by the operator of the equipment. Care should be taken to see that all eye and face safety precautions are followed by the operator. **ALWAYS WEAR SAFETY GLASSES.** Everyday glasses only have impact resistant lenses, they are not safety glasses.
2. Read and understand this manual before operating. Abuse and misuse will shorten the functional life.
3. Be sure the aligner is properly connected to the power supply and electrically grounded.
4. Do not operate equipment with a damaged cord or if the equipment has been dropped or damaged – until it has been examined and repaired by a qualified serviceman.
5. Do not let cord hang over edge of table, bench, or counter or come in contact with hot manifolds or moving fan blades.
6. If an extension cord is necessary, a cord with a current rating equal to or more than that of the equipment should be used. Cords rated for less current than the equipment may overheat. Care should be taken to arrange the cord so that it will not be tripped over or pulled.
7. Keep guards and safety features in place and in working order.
8. Wear proper clothing. Safety toe, non-slip footwear and protective hair covering to contain hair is recommended. Do not wear jewelry, loose clothing, neckties, or gloves when operating the aligner. Care must be taken around hot parts, as they can burn.
9. Keep work area clean and well lighted. Cluttered and/or dark areas invite accidents.
10. Avoid dangerous environments. Do not use power tools or electrical equipment in damp or wet locations, or expose them to rain.
11. Avoid unintentional starting. Be sure the aligner is turned OFF and power disconnected before servicing.
12. Use only manufacturer’s recommended accessories. Improper accessories may result in personal injury or property damage.
13. Repair or replace any part that is damaged or worn and that may cause unsafe aligner operation. Do not operate damaged equipment until it has been examined and serviced by an authorized service technician only. This unit contains no user serviceable parts.
14. Do not allow untrained persons to operate machinery.
15. To reduce the risk of fire, do not operate equipment in the vicinity of open containers or flammable liquids (gasoline).
16. Adequate ventilation should be provided when working on or operating internal combustion engines.
17. Keep hair, loose clothing, fingers, and all parts of body away from moving parts.
18. Use equipment only as described in this manual. Do not modify the unit or remove protective covers or housings.
19. Use only manufacturer’s recommended attachments and accessories.

SAVE THESE INSTRUCTIONS

Important Safety Instructions

Owner's Responsibility

To maintain machine and user safety, the responsibility of the owner is to read and follow these instructions:

- Follow all installation instructions.
- Make sure installation conforms to all applicable Local, State, and Federal Codes, Rules, and Regulations; such as State and Federal OSHA Regulations and Electrical Codes.
- Carefully check the unit for correct initial function.
- Read and follow the safety instructions. Keep them readily available for machine operators.
- Make certain all operators are properly trained, know how to safely and correctly operate the unit, are properly supervised, and have a thorough knowledge of the operation and safety features of the alignment rack or lift.
- Allow unit operation only with all parts in place and operating safely.
- Carefully inspect the unit on a regular basis and perform all maintenance as required.
- Service and maintain the unit only with authorized or approved replacement parts.
- Keep all instructions permanently with the unit and all decals/labels/notices on the unit clean and visible.
- Do not override safety features.

Operator Protective Equipment

Personal protective equipment helps make tire servicing safer. However, equipment does not take the place of safe operating practices. Always wear durable work clothing during tire service activity. Loose fitting clothing should be avoided. Tight fitting leather gloves are recommended to protect operator's hands when handling worn tires and wheels. Sturdy leather work shoes with steel toes and oil resistant soles should be used by tire service personnel to help prevent injury in typical shop activities. Eye protection is essential during tire service activity. Safety glasses with side shields, goggles, or face shields are acceptable. Back belts provide support during lifting activities and are also helpful in providing operator protection. Consideration should also be given to the use of hearing protection if tire service activity is performed in an enclosed area, or if noise levels are high.

Definitions of Hazard Levels

Identify the hazard levels used in this manual with the following definitions and signal words:

DANGER

Watch for this symbol:



It Means: Immediate hazards, which will result in severe personal injury or death.

WARNING

Watch for this symbol:



It Means: Hazards or unsafe practices, which could result in severe personal injury or death.

CAUTION

Watch for this symbol:



It Means: Hazards or unsafe practices, which may result in minor personal injury or product or property damage.



Watch for this symbol! It means BE ALERT! Your safety, or the safety of others, is involved!

Table of Contents

I. Introduction	2
1.1 Warning	2
1.2 Safety Warning	2
II. Getting Started	4
2.1 Equipment Transport Conditions	4
2.2 Product Description	5
2.3 Equipment and Servicing	5
2.3.1 Check List	5
2.3.2 Camera Care	5
2.3.3 Target Care	5
III. Installation Guide	6
3.1 Installing Wheel Clamps and Target	6
3.1.1 Installing wheel clamp or Tire Clamp	6
3.1.2 Fixing Targets	7
3.2 Installing/Removing Brake Depressor	7
3.3 Installing/Removing Steering Wheel Holder ..	8
3.4 Recommended Distances	8
3.5 Positioning	9
IV. Software	10
4.1 Starting the Software	10
4.2 Function Keys	10
4.3 Visual Check	12
4.4 Standard Measurement	12
4.5 Quick Measurement	18
4.6 Random Measurement	19
4.7 Enhanced Measurement (OEM Routine)	21
4.8 Aligner Management	23

V. Technical data	27
5.1 Measuring Range	27
5.2 Power Supply Unit	27
Appendix I . Faults in operating sequence	28

I. Introduction

The purpose of this manual is to provide the owner and operator of the imaging wheel aligner with safe and practical instructions for its use and maintenance.

Following all instructions carefully will assist you in your work and give long term and efficient service. The following paragraphs define the levels of danger associated with warning captions in this manual.

1.1 Caution

The Aligner is designed for INDOOR USE ONLY. Exposure to damp or wet locations will cause damage to the aligner's components or injury to the user and will void warranty.



The computer may have the ability to connect to the internet, intranet, a local or wide area network. DO NOT connect the computer to any network or the internet unless instructed to by a manufacture or authorized technician.



DO NOT install any 3rd party software or hardware into or onto the aligner as it may cause conflicts with Aligner software or drivers. Failure to comply will void aligner warranty.



Do not plug the cabinet power cord in until all connections have been verified. Damage or injury can result.

Ensure all installations on this aligner are legal in your country.

1.2 Safety Warning

This Imaging Aligner is intended for use by properly trained, skilled automotive technicians. The safety messages presented in this section and throughout the manual are reminders to the operator to exercise extreme care when performing wheel alignments with this product.

There are many variations in procedures, techniques, tools, and parts for servicing vehicles, as well as the skill of the individual doing the work. Because of the vast number of vehicle applications and potential uses of the aligner, the manufacturer cannot possibly anticipate or provide advice or safety messages to cover every situation. It is the automotive technician's responsibility to be knowledgeable of the vehicle to be aligned. It is essential to use proper servicing methods and perform wheel alignments in an appropriate and acceptable manner that does not endanger operator safety, the safety of others in the work area, the equipment or vehicle being serviced.

Read this manual carefully before powering up the equipment. Store this manual and all illustrative material supplied with the equipment in a folder near the equipment where it is readily accessible for the operator.



Risk of entanglement or crushing. There are moving parts on vehicle lifts during operation.

- Keep all persons clear of lifts.
- Read lift manufacturer's operation instructions carefully.
- Follow lift manufacturer's safety recommendations.

Contact with moving parts could cause injury



Risk of pinching or crushing body parts when jacking vehicles.

- Keep hands and other body parts away from jacking surfaces.
- Do not use unapproved adapters (i.e. wooden blocks) when jacking a vehicle.
- Do not bypass any jack manufacturer's safety features.
- Read jack manufacturer's operation instructions carefully.

- Follow jack manufacturer's safety recommendations.

Improperly used or maintained jacks can cause injury.



Risk of crushing. Vehicles may roll off alignment lift if not secured.

- Leave automatic transmission in park or manual transmission in gear unless equipment operation steps require vehicle in neutral.
- Apply parking brake unless equipment operation steps require wheel movement.
- Use wheel chocks whenever vehicle is positioned on the lift.
- Follow rack or lift manufacturer's safety recommendations when lifting a vehicle.

Vehicles rolling off lifts can cause death or serious injury.

The technical documentation supplied is considered an integral part of the equipment; in the event of sale all relative documentation must remain with the system.

This manual is only being considered valid for the equipment of the model and with the serial number indicated on the nameplate applied to it. The nameplate is attached to the back of the cabinet.



Without prior knowledge to the manufacture or manufacture authorized dealers, any alterations to this aligner may cause serious injury. The manufacture is not responsible for any injury caused by improper use, abuse, or unauthorized repair.



This aligner is compatible with scissor alignment lifts and 4 post alignments lifts that allow a clear camera line of sight to the front and rear alignment targets. 4 post lifts with excessively wide front yokes or pulley covers, may restrict this camera line of sight.

II. Getting Started

2.1 Equipment Transport

Conditions

The aligner must be shipped in its original packaging and stowed in the position indicated on the outside.



To avoid damage, never place other items on top of the packaging.

Handling of the aligner must be performed only with an appropriate lifting device such as a forklift or pallet jack with rated capacity of 527 lbs (239 kg).

Only personnel who are experienced and qualified on material handling procedures should handle any transportation or moving of the aligner.

Inspect for any damage to the crate and notify local distributor (and/or transport company) immediately if any damage is observed.

Uncrating Instructions:

Carefully remove the crating and packing materials and all skid and pallet fasteners. Be careful when cutting banding material as items may become loose and fall causing personal harm or injury. Always wear gloves when uncrating the machine to prevent scratches, abrasions, or cuts due to the contact with packing materials. Retain all packaging in the event you need to return any parts for warranty or servicing. Carefully

unpack and inventory all items. Familiarize yourself with all components before beginning set up and assembly.

Brake Depressor	1
Manual	1
Power cord	1

2.2 Product Description



Please use the original accessories produced by manufacturer. The manufacturer is not liable for any damage or injury caused by improper use.

2.3.2 Camera Care

Keep hand and tools away from camera.

No grease on the lenses. Use a nonabrasive cleaner with soft cloth to clean lenses if necessary. Do not apply cleaner directly to the lenses.

2.3.3 Target Care

Keep targets clean, handle with care

- Both hands should be clean when using target.
- Keep hands and tools away from surface of targets.
- Keep wheel clamp and target firmly attached, avoid dropping the targets.

2.3 Equipment and Servicing

2.3.1 Check List

Standard Configuration:

Name	Qty
Computer	1
Post	1
Monitor	1
Cabinet	1
Software	1
Printer	1
Target	1 set
Wheel Clamp	4
Wheel Stopper	2
Steering Wheel Holder	1

- No grease on the surface of targets, use a nonabrasive cleaner and soft cloth to clean target. Do not use a workshop cloth.



Do not use water or pressurized water to clean the target. Do not use a detergent directly on the target. Improper use may break the target.

When the aligner system cannot detect color line on the targets, clean the target with care first. When the targets are not in use, attach the target to the clamp and store them on the cabinet. Do not put target face downward onto any surface.

III. Installation Guide

3.1 Installing Wheel Clamps and Target

3.1.1 Installing wheel clamp or Tire Clamp Instructions

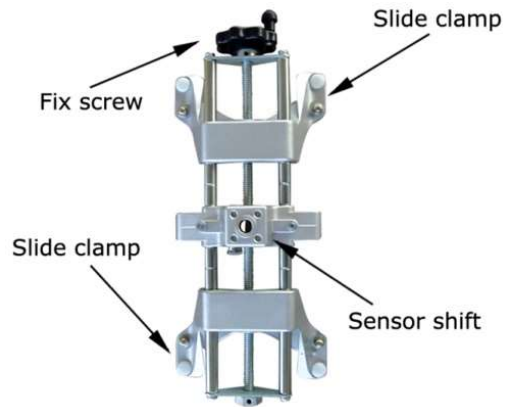

Diagram: Wheel clamps



Diagram: Quick wheel clamps



Different wheels may have different clamping mechanisms. Special adapters may be required when using high end wheel.

Only use a universal wheel clamp to do run out compensation.

Place the handle on the clamp approximately 20 degrees forward towards the front of the

vehicle, aligning the leading black plastic cover and trailing metal clamp leg parallel to the alignment surface.



As with any alignment wheel clamp, damage from dropping can cause inaccurate readings. Take care to not drop clamps or damage them.

3.1.2 Fixing Targets

Check to see if the wheel clamp is firmly attached to the wheel. Lightly lubricate the socket pins of the target to protect the pin and socket. Mount two small targets in the front and bigger one in the rear. Please keep the spirit level upside.

3.2 Installing/Removing Brake Depressor



Diagram: Installing/Removing brake depressor

Ensure the brake depressor is properly installed. Place a cloth underneath if necessary. After run out compensation, fit the brake depressor for further measurements.



3.3 Installing/Removing Steering Wheel Holder

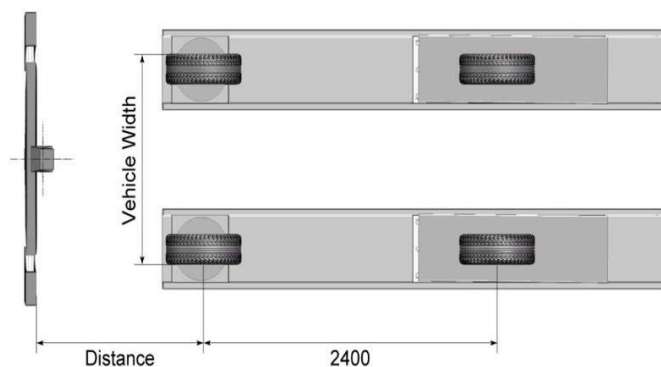

Diagram: Installing/Removing steering wheel holder

The steering wheel holder must hold the steering wheel in position and block the wheels.

1. Place the steering wheel holder on the seat and press the plate against the seat.
2. Slide the base downwards against the seat.
3. Release the holder so that pressure is exerted on the steering wheel by way of the seat cushion.
4. Remove in the reverse order. Ensure the steering wheel holder is properly installed. Place a cloth underneath if necessary. After runout compensation, install the brake depressor for further measurements.

3.4 Recommended Distances



Distance	Vehicle Width (Min.)	Vehicle Width (Max)
71"	60 3/8"	71 7/8"
83"	58 1/2"	74 1/8"
95"	56 7/8"	76 1/2"
110"	55 1/8"	77 3/4"

d=1800mm-3000mm or 71"-120"

d=2800mm or 110" is recommended for North American

d=2400mm is recommended for Europe and Asia Pacific Regions

3.5 Positioning

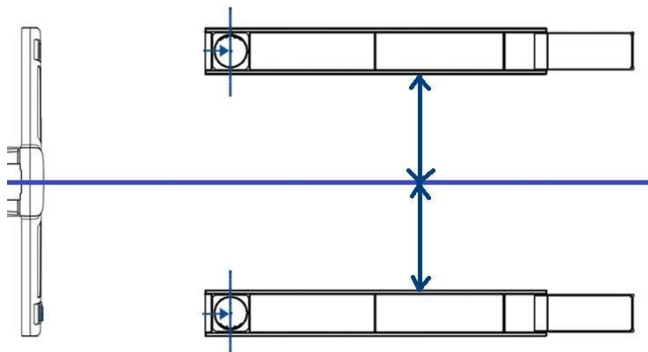

Narrow and wide vehicles should be carefully centered on the alignment platform to ensure even camera view.

Use of the “Aligner Test” screen is recommended when installing the aligner to ensure the aligner is properly centered.

To check using “Aligner Test” screen, from Home screen, go to management-maintenance-aligner test.

There are two camera windows, the left one is for left camera and targets, and the right one is for right camera and targets.

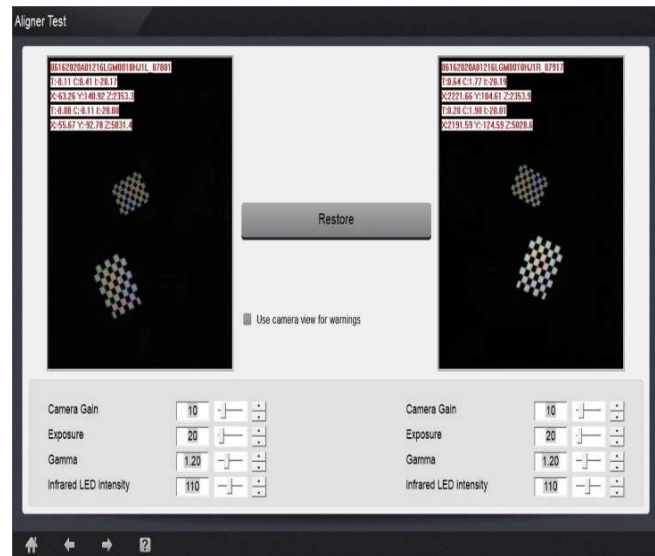

On each side, the top line is the serial number of the camera. The character before the “_”, either L or R, means Left or Right.

The 2nd line is for front target, the abbreviation I, C and T stands for Incline, Camber and Toe. The displayed numbers are raw numbers measured from the camera.

The 3rd line X,Y,Z are the coordinates of the targets in reference to the camera.

X value on the left side is the horizontal offset between the left camera to the center of the left target. The X on the right side is the offset between the left camera to the center of the right camera, seen and calculated by the right camera.

Y value is the offset vertically, or the height offset, between the camera to the center of the target.

Z value is the distance from the camera to the center of the target.

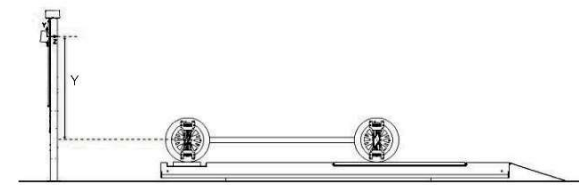
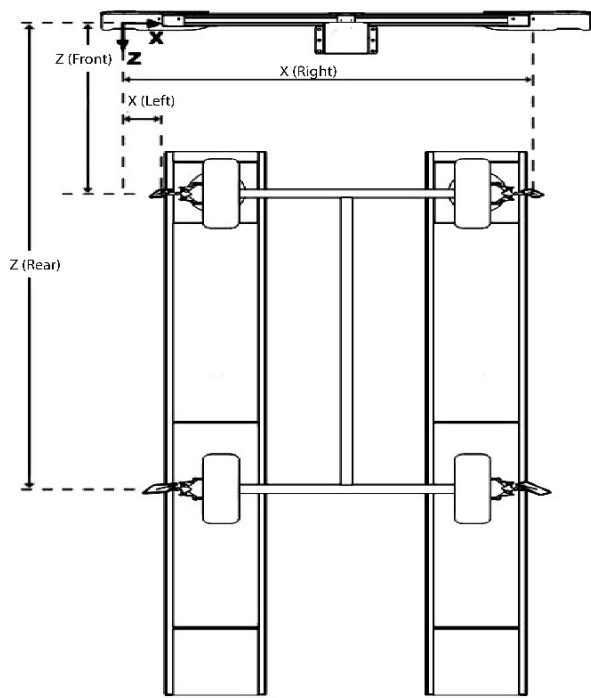

The 4th and 5th line are for rear target.

To check if the camera beam is centered, all targets should be seen in the camera view window, and positioned relative in the center. The top and bottom target image should not be too close as they may overlapping in some cases.

Please do note that shortened bay installations result in a limited camera view. Extra care must be taken to ensure the support and camera beam are centered symmetrically to the alignment surface.

IV. Software

4.1 Starting the Software

Turn on the power, start the PC. The software should start with the Windows operating system. If it doesn't start, find the alignment

software icon on the desktop,







double

click and run.

If you cannot locate the shortcut, please check if the software is properly installed or contact the nearest service provider.

4.2 Function Keys

This aligner operated with standard IBM keyboard, there are 12 function keys, F1 – F12. On the right side of the keyboard, there are special function keys such as Page Up, Page Down, Home and arrow keys. The function keys are used as shortcuts to quickly access the software as illustrated below.

Icon	Function
	F10 - Help
	PgUp - Previous
	PgDn - Next
	Home – Main screen. Using "Home" key from any screen will back to main screen.



Please do NOT switch off power supply directly to shut down the computer. Switching off power directly may affect proper operation of the Microsoft Windows system.

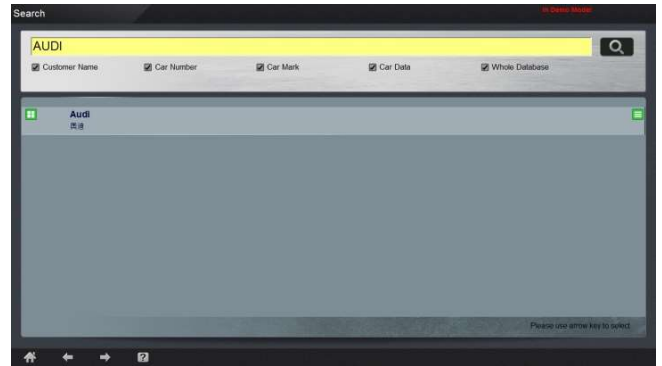

Diagram: Database search

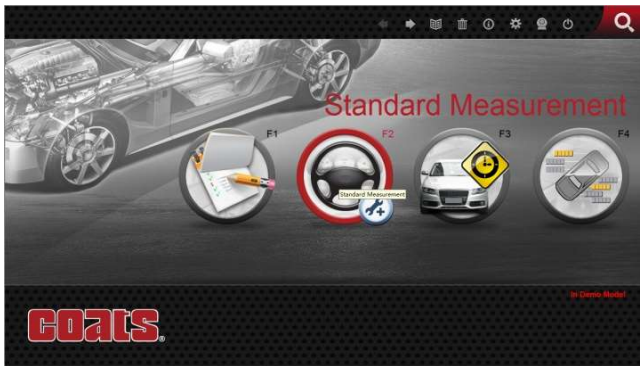

Diagram: Main screen

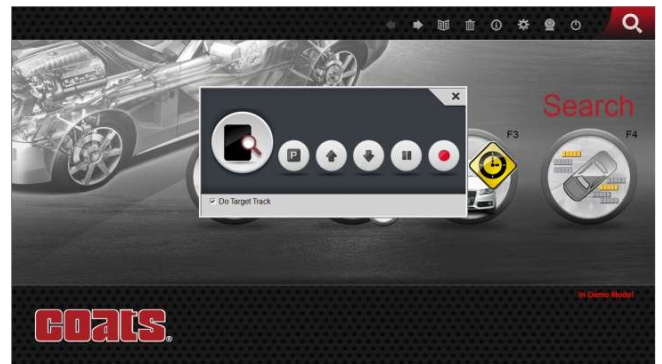

Diagram: Auto tracking

Auto Tracking setup /control, access by Shift + F4. Target tracked must be checked for auto tracking to function properly.

Icon	Function	Icon	Function
	Help		Previous
	Next		Clear Measurement
	Exiting the program		Version Information
	Settings		Search
	Aided Drive On (may not be available on all models)		

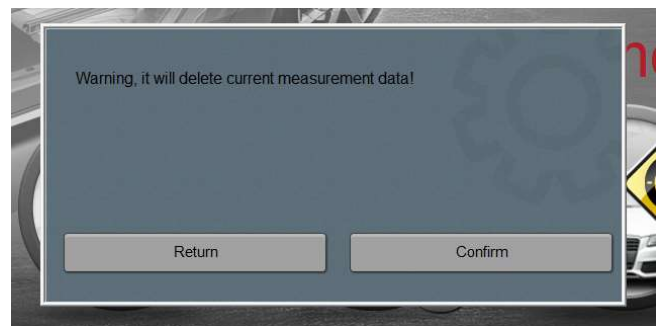



Diagram: Clear measurement

4.3 Visual Check



Click  Or press F1 to enter visual check.

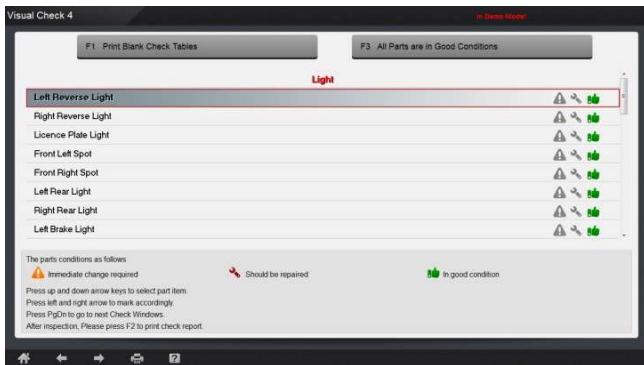







Diagram: Visual Check

Symbol	Function
	Defective, replacement needed
	Warning, repair needed
	Normal, no action needed
	Next: Enter next screen
	Print: Print check table or check report as desired

Please note that if you press F1 to print check table, the software will assume to print a table for manual checkup. If you want a printed report, please follow each section and carefully mark each part, then press the print icon in the last page to print a full report.

4.4 Standard Measurement

Click on standard measurement icon



 or F2 to enter standard measurement.

Standard measurement is recommended for all alignments and must go through an 8-step setup.

Select customer → Select Vehicle Make Model Year → Runout Compensation → Caster Sweep → Rear Axle Adjustment → Caster Adjustment → Front Axle Adjustment → Result(Print)

1. In the customer information screen



 , click add new customer to enter customer information.

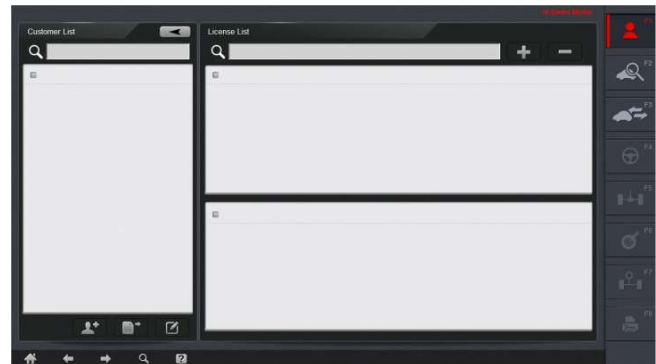

Diagram: Standard measurement- customer information



2. Select Manufacturer –Year – Model or



Manufacturer – Model Year

To setup the display method, please see section Configuration.

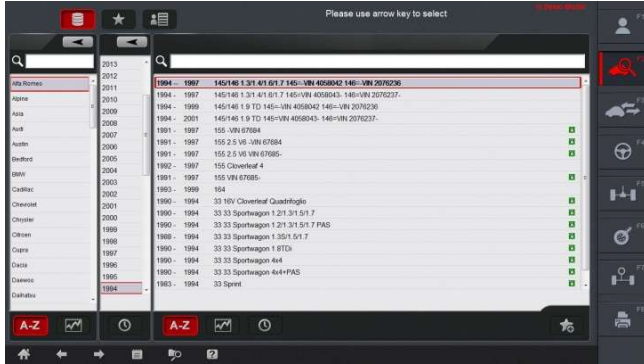

Diagram: Standard Measurement –Vehicle Selection (Manufacturer – Model –Year)

The manufacturer, year and model list can be sorted in different order.

A-Z is to sort in alphabetical order.



Is to set frequency of use.

Time icon is to set current year.

If you can't find a desired manufacturer or model, please contact the nearest service center.

Click next or PgDn key to go next screen.



Diagram: Standard Measurement – Manufacturer Specification

3. Runout Compensation



It is always recommended to do runout compensation. Skipping runout compensation will result in inaccurate readings. There are multiple ways to do runout compensation.

Icon	Feature	Icon	Feature
	Standard		Split
	One way (forward)		One way (Backward)
	Random		Raised
	Quick		Automatic To next step
	Audio Guidance		Switch Clamp

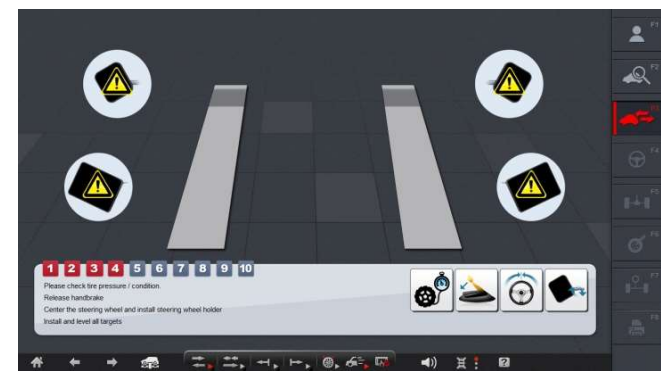

Diagram: Target warning issue

The alignment software checks and ensures each target is in good condition with each runout. If the target is out of calibration, a yellow triangle warning sign with an

exclamation mark on it will appear after the runout. A new runout is required. The warning sign will appear on the target that is out of calibration.

If the warning is shown on a target, please ensure that the mounting of the wheel clamp and tire clamp is correct. Also check to see if any parts of the target are loose or moving. A target calibration is required if the problem persists.

To start runout compensation, please follow the procedure below.



1) You must put the wheel chock in front of one rear wheel, and the other one at the back of the same wheel to prevent the vehicle from leaving the measurement platform.

Check tire pressure and condition of the tire, leave the emergency brake in neutral and the transmission is set to N, make sure the steering wheel is straight. Level all targets until the check sign is all green.



Diagram: Target leveling

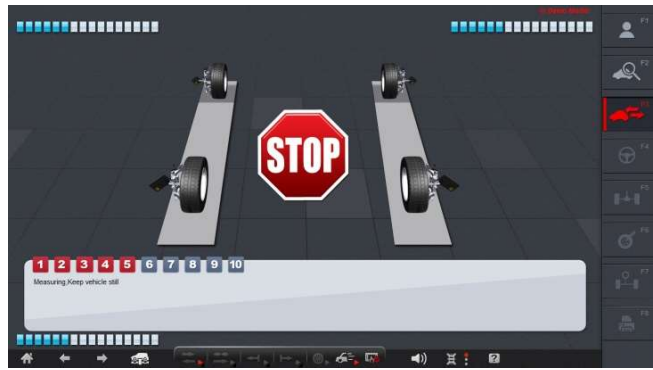

Diagram: Run out compensation

2) Push the vehicle back according to the instruction shown on the screen until the sign says Stop.

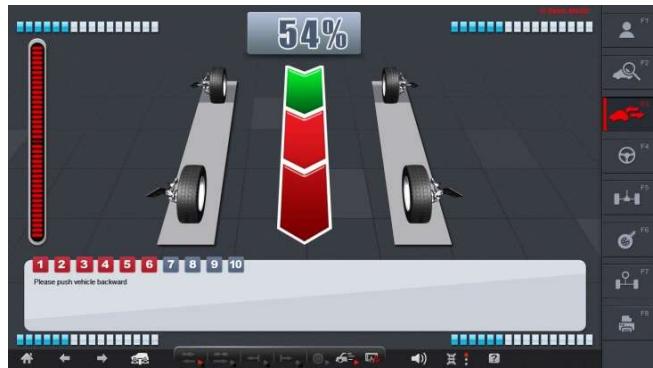

Diagram: Run out compensation

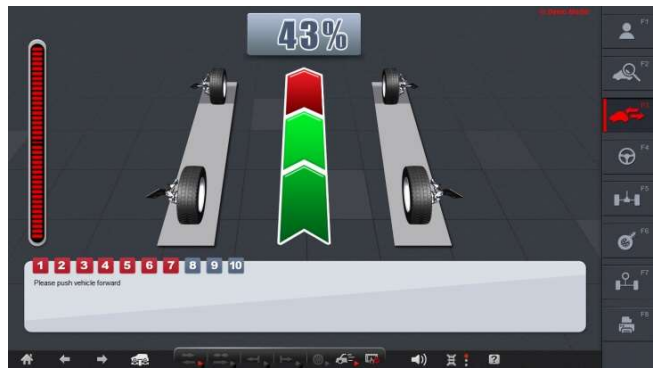

Diagram: Run out compensation

3) Push the vehicle back to the original position, then stop.

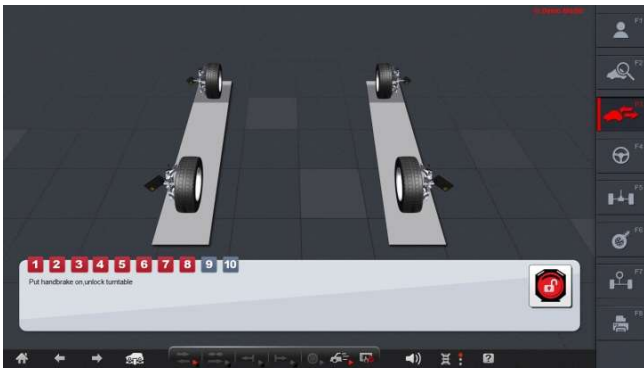

Diagram: Run out compensation

4) Put the wheel chocks and brake depressor on.

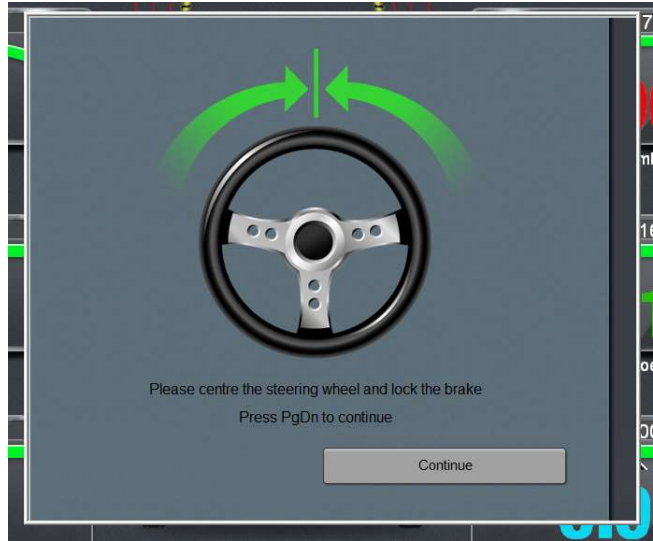

Diagram: Steering wheel straight

4. Caster Sweep



A selection of 7 degree, 10 degree or 20 degree. A quick sweep can be set to speed up the process. When quick sweep is enabled, a red triangle is show at the bottom right corner of each selected angle.



Diagram – Standard measurement- Rear axle measurement

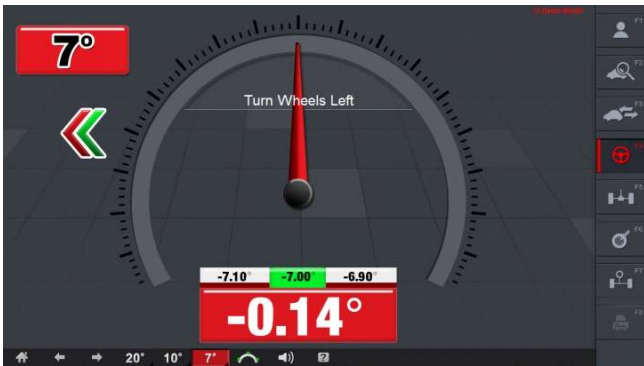
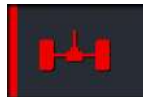

Diagram: Standard Measurement – Caster Measurement

5. Rear Axle Measurement



Make sure the steering wheel is centered and locked after the caster sweep before entering the rear axle measurement screen.



Red means out of manufacturer specification.



Green means within manufacturer specification.







Blue means right on manufacturer specification.



Grey means no manufacturer specification is chosen.



Diagram: Zoomed in, Rear wheel toe

Symbol	Function
	Zoom in – to magnify the displayed value
	Adjustment illustration
	Raised mode
	Additional Measurement

6. Caster adjustment

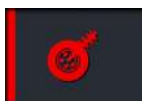

Diagram: Standard Measurement- Caster Adjustment



Please note that caster measurement is a calculated value based on a mathematical model, caster sweep is always recommended after caster adjustment.

See Enhanced measurement section which mandatory caster sweep after caster sweep to ensure accuracy.

7. Front Axle measurement



Diagram: Standard measurement – Front axle

Icon	Feature
	Toe Plus
	Toe Curve
	All Data

Toe Plus: Display the toe measurement as the steering wheel is centered for some hard to reach adjustment point.

Toe Curve: Apply to certain vehicles in VAG group, which adjust toe value regarding to the manufacturer specific ride height. Optional Accessories are required to use with this feature.

All Data: Display live values include toe Front and Rear, camber, SAI, Included angle, tire diameter etc. values on one screen to give an overall condition of the vehicle.

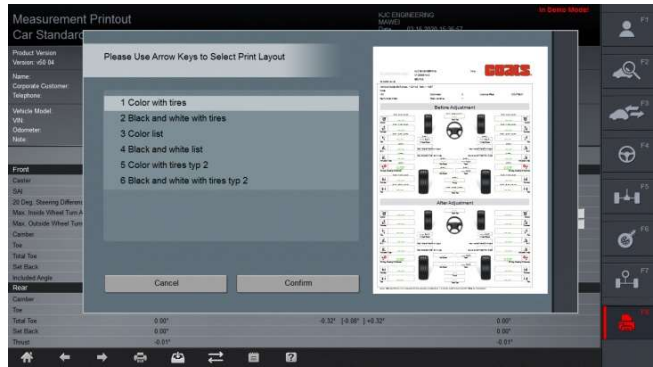

Diagram: Printout format selection

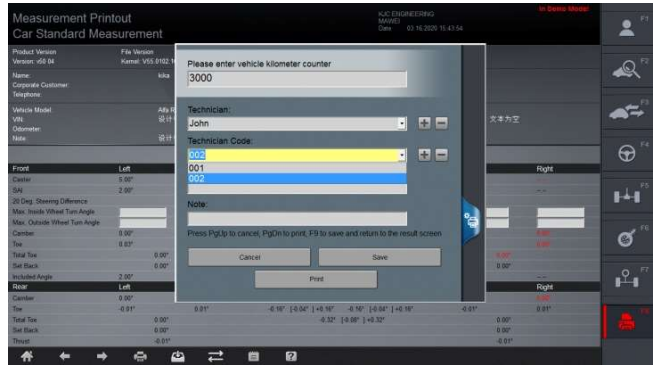





Diagram: Saved technician name and technician code.

8. Print



Diagram: Standard measurement – print

On this screen, the value in red is out of tolerance, the value in black is within specs.

Icon	Feature
	Print
	Save
	Manufacturer Spec
	Compare: compare values with previously measurement report

4.5 Quick Measurement



From main screen, click or F3 to enter quick measurement.

Quick measurement: Select vehicle → Run out compensation → Front/Rear Axle → Print.

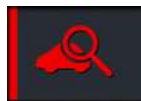

1. Select vehicle



Diagram: Quick Measurement – Select vehicle manufacturer, year and model

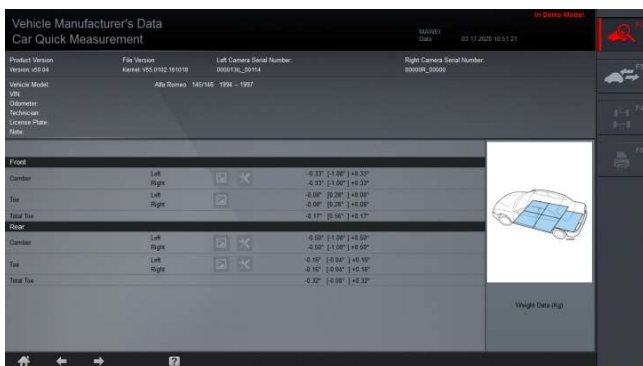

Diagram: Quick Measurement – Manufacturer spec

2. Run out compensation

After selecting vehicle spec, do run out compensation and follow the instruction indicated.

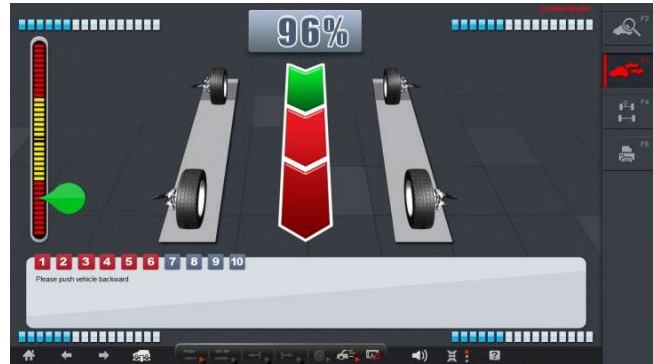

Diagram: Quick Measurement – Run out compensation



3. Front/Rear Axle



Diagram: Quick Measurement –Front / Rear Axle

Front/Rear Axle screen displays front and rear camber, front and rear toe, front and rear total toe and thrust angle.

Note:

Front/Rear Axle screen is disabled before doing complete run out compensation.

4. Print



Diagram: Quick Measurement –Print

4.6 Random Measurement



From Main screen, select  or press F4 to access

Diagram: Random Measurement – Run out Compensation



Diagram: Random Measurement –Toe and camber measurement



Diagram: Random Measurement – All data



Diagram: Random Measurement



Diagram: Random Measurement – Additional Measurement

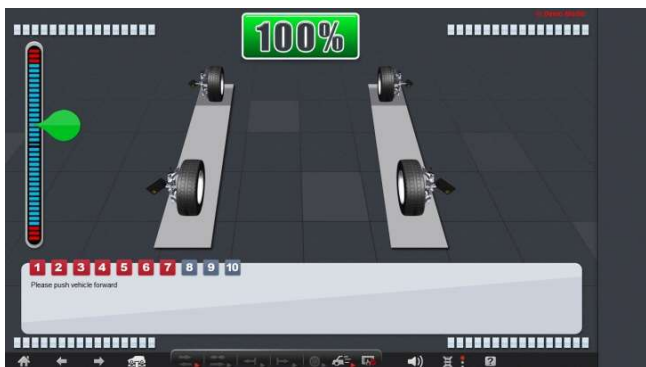

Important: Always read and follow instructions.



Diagram: Random Measurement – Caster Measurement



Diagram: Random Measurement –Toe Curve

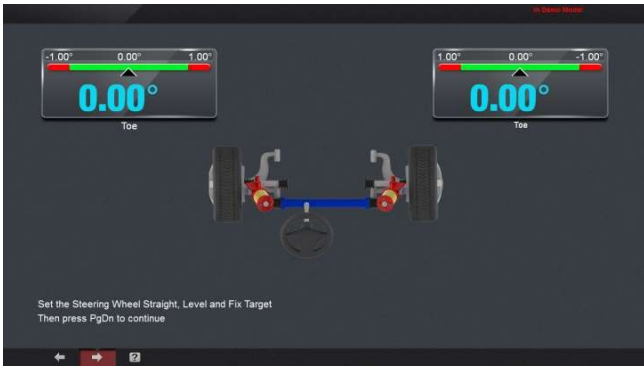

Diagram: Random Measurement –Toe Plus



Diagram: Random Measurement – Steering wheel

This aligner is capable of connecting a ROMESS steering wheel centering tool to display the real condition of the steering wheel in degrees. The COM port of the Romess device must be set in order to work correctly. Please check the port setting in device manager, and then select in the alignment software.

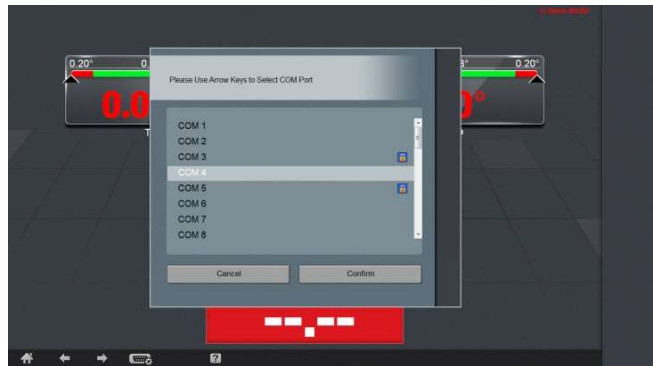

Diagram: Random Measurement –COM Port Setup



Diagram: Random Measurement – access other program

There are four programs that can be accessed within the alignment program, such as a link to a favorite website or teamviewer remote help program. Simply hold shift while selecting one of the icons, then select the program you wish to access.

4.7 Enhanced Measurement

(OEM Routine)

The enhanced measurement can be accessed by pressing Shift while clicking the standard measurement on the main screen.



, the icon changes and a wrench icon is displayed in the bottom right corner.



The main difference between the standard measurement and enhanced measurement is the way the caster sweep is set. In the enhanced mode, a 2nd caster sweep is always performed to ensure the real caster value is reflected on the report.



1. Customer Information

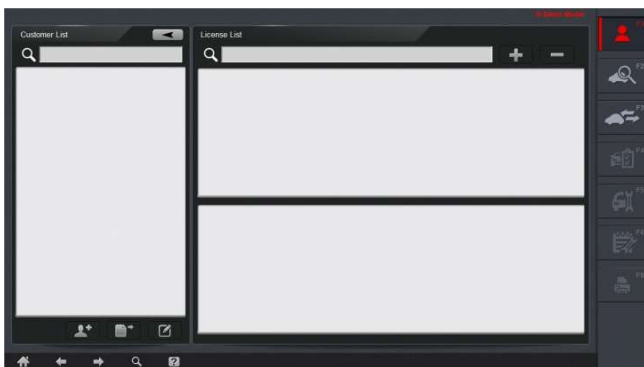

Diagram: Enhanced measurement – Customer information



2. Vehicle Selection

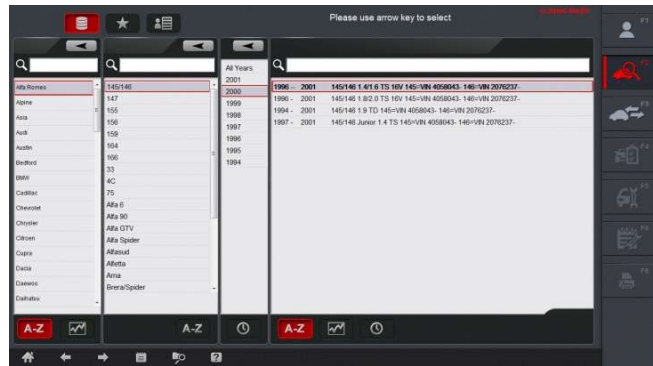

Diagram: Enhanced Measurement – Select Vehicle



3. Run out compensation

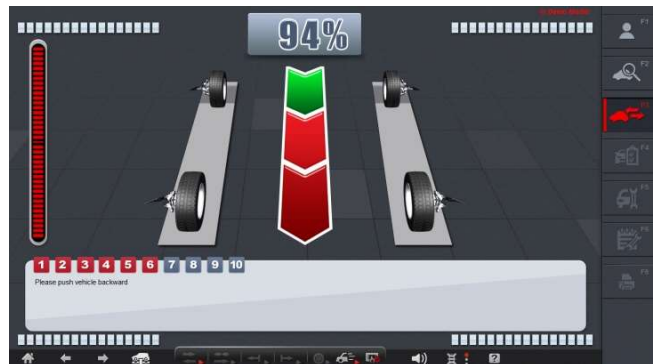

Diagram: Enhanced Measurement –Runout Compensation

4. Initial measurement



Diagram: Enhanced Measurement –initial measurement

5. Initial measurement – Overall condition of the vehicle



Diagram: Enhanced Measurement –All Data



Diagram: Additional measurement

6. Rear Axle Adjustment



Diagram: Enhanced Measurement – Rear Axle

7. Front Axle Adjustment



Diagram: Enhanced Measurement –Front Axle

8. Caster Adjustment



Diagram: Enhanced Measurement –Caster Adjustment

9. Final Check

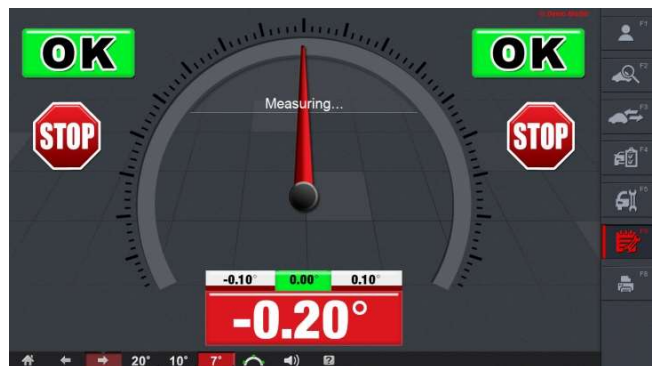

Diagram: Enhanced Measurement –Caster Check

10. Overall Condition



Diagram: Enhanced Measurement –Overall condition

11. Print



Diagram: Enhanced Measurement – Print

4.8 Aligner Management



From main screen, click  or press F5 on the keyboard for aligner management.

Use this screen to access version number, settings, maintenances, customer information and database management.



Diagram: Aligner management



- Click  icon or press F1 to display software versions.

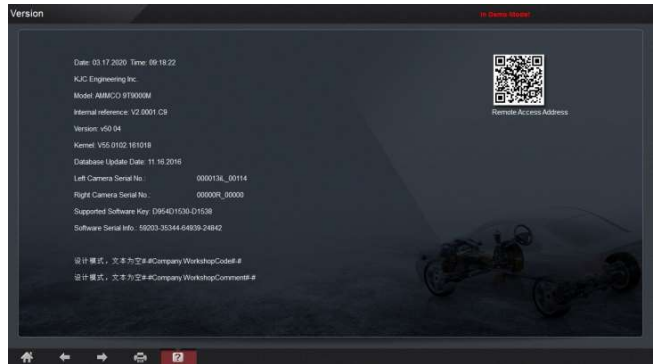

Diagram: Version info



- Click  icon or press F2 to changes aligner settings



Diagram: Aligner setting with selection of display language

Settings:

F1: Language: Use "PgDn" to confirm.

F2: Demo mode: Software displays each screen without connecting cameras. In demo mode, use Ctrl+left arrow key to demo vehicle moving forward and turning steering left or Ctrl+right arrow for vehicle moving backward or turning steering right.

F3: Caster Sweep: 10 or 20 degree.

F4: Measurement Mode: Four wheel or two wheel mode.

F5: Unit of measurement: Choose 1/60 degree or 1/100 degree.

F6: Unit of rim diameter and distance display: choose mm or inch.

F7: Toe value unit: choose degree, inch or mm.

If select mmm or inch as toe unit, enter tire diameter before measurement.

F8: Value precision: choose 0.01, 0.05 or 0.1, rounding of measurement result.

F9: Order of Vehicle.

F10: Spacial Dynamics.

F11: Lift Height Checking.



- Click  or F3 enter maintenance screen. Enter password "admin".

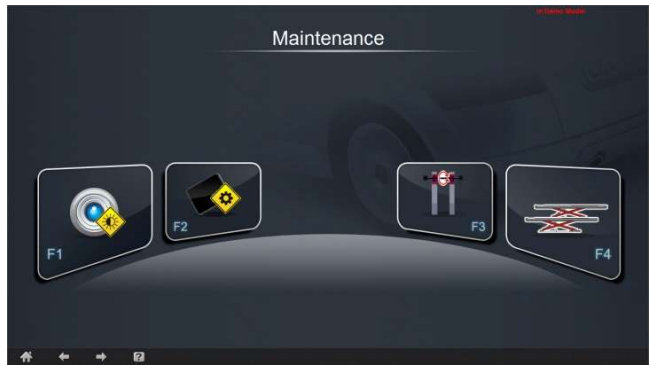

Diagram: Maintenance

In this screen, calibrate aligner either as target calibration, camera frame calibration, lift level calibration or thrust angle calibration.

Enter maintenance, press "F9" 6 times to select simplified calibration procedure.

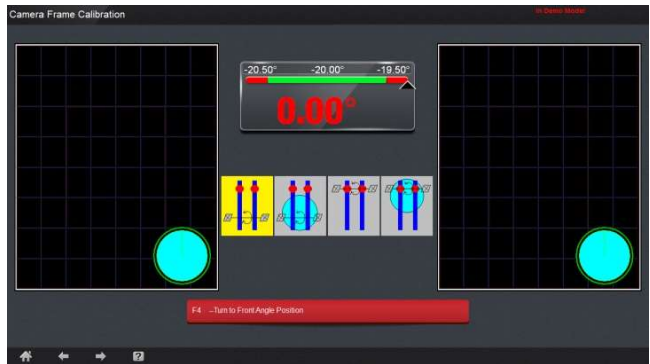

Diagram: Simplified camera calibration



Diagram: Aligner test

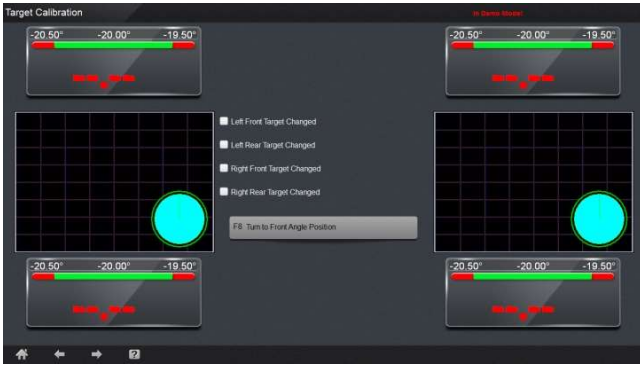

Diagram: Target Calibration



Diagram: Database management



Diagram: Aligner calibration

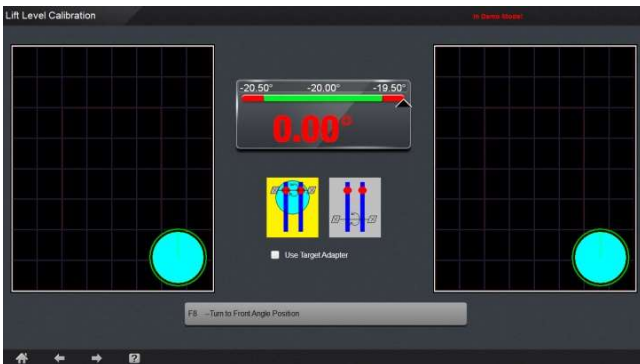

Diagram: Lift calibration

Database management includes vehicle database and customer database management. Operator can enter custom vehicle specs into database.

Database manager:



- Click  or click F1 to add vehicle spec. Use arrow key to select manufacturer. Click F1 again if the manufacturer is not available. When adding a new manufacturer, select nation first.



Diagram: Select manufacturer

- Click  or press F4 to enter database management. Enter password as "admin".

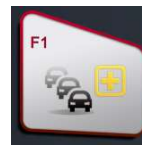

Diagram: Selection nation of manufacturer

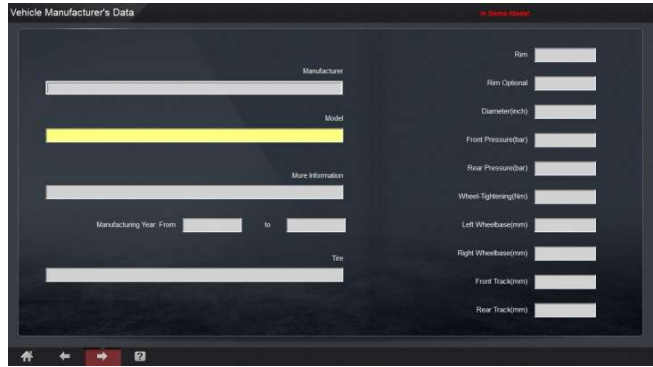

Diagram: Vehicle spec

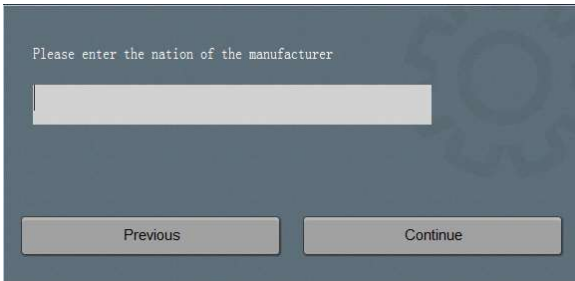

Diagram: Enter the nation of manufacturer



Diagram: Manufacturer name



Diagram: Vehicle Spec – Front Axle

After entering front axle info, press PgDn to next screen.

Press PgDn to enter vehicle spec screen. Use arrow key to access different blocks.

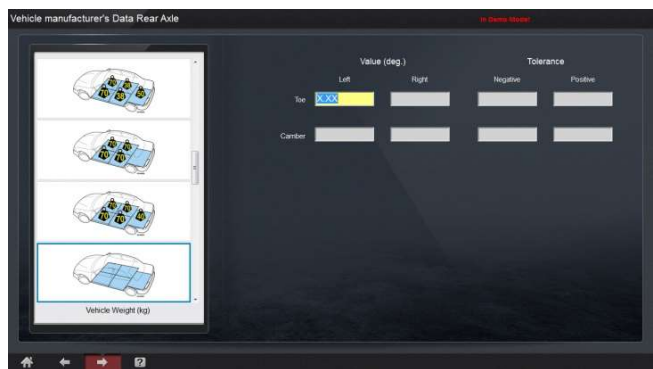

Diagram: Vehicle Spec – Rear Axle

Press PgDn when finished to enter next page-leaving factory data.

Screen displays all data input. Check and edit data by using PgUp to go back to previous page.

Press PgDn to leave the factory data screen when you're finished editing.

When you're finished, press PgDn to save the data. Then Go back to the databank manager screen.



- Click  or F2 to edit manufacturer spec.



- Click  or F3 to update vehicle data.

V. Technical data

5.1 Measuring Range

Options	Range
Total Toe (Front and Rear Axle)	±50°
Individual toe (Front axle)	±25°
Camber (Front and Rear Axle)	±15°
Setback	±9°
Thrust Angle	±9°
Caster	±22°
King pin	±22°
Wheelbase	1.2-2.1m
Track width	1.8-4.5m
Tire Diameter	250-800mm

5.2 Power Supply Unit

Function	Specification
Power supply(voltage)	220-240V
Frequency	50/60Hz
Power	1Kw

Appendix I . Faults in operating sequence

Description	Remedy
Computer does not start.	<p>Check if the power cable is firmly connected, check if the computer switch lights on.</p> <p>Check the power bar is working properly.</p> <p>Check fuses in cabinet.</p> <p>Check power cable.</p> <p>Check if power cable has output voltage.</p> <p>Contact local authorized service center.</p>
No display on monitor.	<p>Check if monitor switched on.</p> <p>Check if cable is firmly connected.</p> <p>Check power cable.</p> <p>Check VGA or DVI cable is connected.</p> <p>Contact local authorized service center.</p>
Computer shuts off due to power surge, after restart, alignment software does not start.	<p>After a power surge, computer software may become corrupted. Use backup software if available to restore to a previous working point. If reloading from OS needed, Contact local authorized service center.</p>
Screen shows a black screen in alignment software and does not close.	<ol style="list-style-type: none"> 1. Check if the target has color lines or if the target is in the measuring range. Adjust the target position if needed. 2. If the target does not have color lines, but both targets are in the range, this can be the problem with both targets overlapping and interruption within the measuring range. 3. If the target does not have color lines, but both targets are in the range, no disturbance objects found, target may be dirty. Clean target with care. 4. Cannot see target clear, but red LED beside camera is flashing. Use a cellphone camera to check if the LEDs are lighting up. Use front camera on an iPhone as the rear camera of iPhone as a special filter. Check power adaptor has output voltage. 5. No target seen on the screen, exit software and rerun alignment software. <p>Contact local authorized service center if needed.</p>
After runout compensation, camber or toe value is very big.	<p>Measurement is interrupted during the measurement. Redo the runout compensation and check value.</p> <p>Contact local authorized service center if needed.</p>

Windows starts ok but alignment software does not start

1. HASP key not found:



- No software key is found on the computer.
- Software key is plugged in but no red light on it, check driver is properly installed.
- If driver is not installed properly, download software key driver from HASP.com.

Contact local authorized service center if needed.

2. Fail to create empty document.

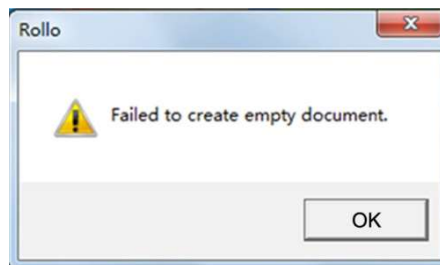

This means database is corrupted.

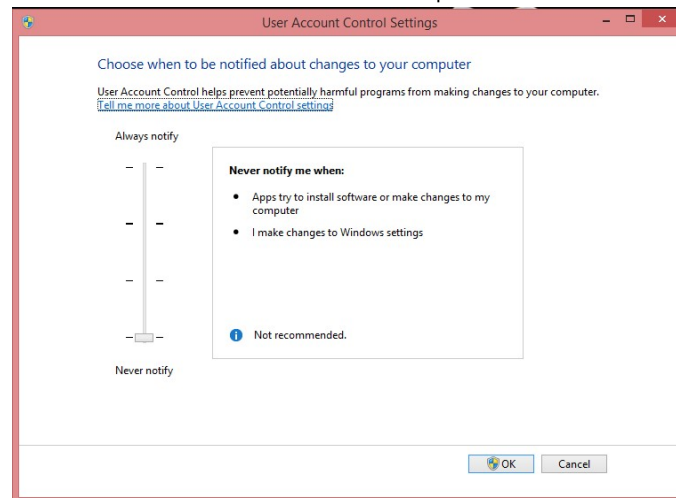

Recover database by going to c:/program files/wheel aligner/carcon

Delete ~carcon3.xpd.

Rerun alignment software.

Check Settings in User Access Control and change the setting to Never

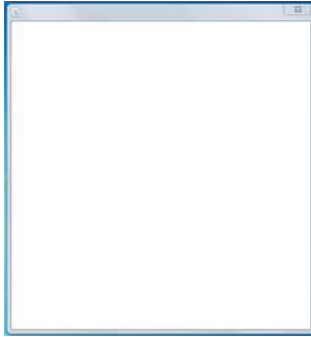
	<p>Control panel- User account and Family safety- user account- change user account. Contact local authorized service center if needed. 3. Executable software does not match software key.</p> 
Camera screen shows white?	Reconnect USB cable from camera to computer first. If does not solve the problem, check connect from USB cable to camera. Change cable if necessary. Contact local authorized service center if needed.
Restore camera data?	Main screen—F5—F3—enter password as " admin"—F3—select backup data—open.
Backup camera data	Main screen—F5—F3—enter password as" admin"—F2—press f4 6 times—enter password as "admin"—save.
Check if post is leveled?	Use magnetic level to check if the post is leveled or not.
Camera adjustment tools?	3mm、 4mm、 5mm Allen key.

NOTES