



PORTABLE EVAPORATIVE COOLERS

**Operation  
&  
Maintenance  
Manual for**

**CS5-16, CS6-36 & CS5-48  
Series**

1-800-557-5716  
[www.cool-space.com](http://www.cool-space.com)  
[sales@cool-space.com](mailto:sales@cool-space.com)



Model No.	CSW-12-VD	CS5-16-VD	CS5-16-VD-TB	CS6-36-1D	CS6-36-3B	CS6-36-VD	CS6-48-2B
Electrical supply	110V / 1ph / 60Hz	110V / 1ph / 60Hz	110V / 1ph / 60Hz	110V / 1ph / 60Hz	110V / 1ph / 60Hz	110V / 1ph / 60Hz	110V / 1ph / 60Hz
Fan size diameter	in. 12	18	18	36	36	36	48
Fan power	hp 1/3	1/2	1/2	1/2	3/4	3/4	1
Fan type	Axial	Axial	Axial	Axial	Axial	Axial	Axial
Fan speed	Variable	Variable	Variable	1-speed	3-speed	Variable	2-speed
Air flow							
- High	CFM 2,200	2,825	2,825	9,500	9,500 / 7,500	9,700	19,600
- Low	CFM 300	700	700		5,900	6,400	12,400
Static pressure ESP	in. WC 0.15	0.15	0.15	0.15	0.15	0.15	0.15
Fan Drive	Direct	Direct	Direct	Direct	Belt	Direct	Belt
Fan Amperage							
- High	A 0.85	2.9	2.9	6.45	8.95 / 6.3	6.3	6.45
- Low	A 0.43	1.45	1.45		3.2	1.8	3.05
Sound Level	dB(A) @ 3ft. 71	63	63	61	61	61	62
Pump Amperage	A 0.06	1.5	1.5	1.5	1.5	1.5	1.5
Cooling media depth	in 4	8	8	8	8	8	8
Cooling media area	ft² 2.25	5	5	20	20	20	30
Cooling capacity	ft² 400 - 600	1100 - 1300	1100 - 1300	3500 - 3700	3500 - 3700	3500 - 3700	3900 - 4100
Water reservoir capacity	gal 10	16	52	46	46	46	64
Water supply			Garden hose connection pressure / gravity feed / hand feed / portable supply tank				
Unit dimensions	in. 23w x 22d x 28h	26w x 24d x 44½h	26w x 24d x 72.5h	62w x 30d x 70h	62w x 30d x 70h	62w x 30d x 70h	75w x 34½d x 84h
Shipping weight	lbs 59	150	180	315	315	315	510



# **COOL-SPACE™**

## **PORTABLE EVAPORATIVE COOLERS**

**Due to continuous product innovations, we reserve the right to change product specification without due notice**

### **Table of Contents:**

#### **1.0 Introduction**

#### **2.0 Unpacking your COOL-SPACE® unit**

#### **3.0 Set-up of COOL-SPACE® unit**

##### **3.1 Connecting the water supply**

##### **3.2 Connecting the electrical supply**

#### **4.0 Operating procedures**

##### **4.1 Filling the unit with water**

##### **4.2 Starting the fan**

##### **4.3 Starting the pump and adjusting the water flow**

#### **5.0 Maintenance and storage**

##### **5.1 Removing the cooling media & accessing the inside of the unit**

##### **5.2 Daily maintenance**

##### **5.3 Periodic maintenance**

##### **5.4 Storage**

#### **6.0 Troubleshooting/Repair**

##### **6.1 Troubleshooting**

##### **6.2 Repair procedures**

##### **6.3 Technical support**

#### **7.0 Warranty**

##### **7.1 Warranty form**

##### **7.2 Warranty parts**

##### **7.3 Optional accessories**

##### **7.4 Common Replacement parts**

#### **8.0 Wiring diagrams**



##### **8.1 CS5-16-2D / CS5-48-2D**

##### **8.2 CS5-36-1D / CS6-36-1D**

##### **8.3 CS5-36-3B / CS6-36-3B**

##### **8.4 CS5-16-VD / CS5-36-VD / CS6-36-VD**

#### **9.0 How evaporative cooling works**

SIGNAL WORD DEFINITIONS		
	<b>DANGER</b>	DANGER indicates an imminently hazardous situation which, if not avoided, <b>WILL</b> result in death or serious injury.
	<b>WARNING</b>	WARNING indicates a potentially hazardous situation which, if not avoided, <b>COULD</b> result in death or serious injury.
	<b>CAUTION</b>	CAUTION indicates a potentially hazardous situation which, if not avoided, <b>MAY</b> result in minor or moderate injury.
	<b>CAUTION</b>	CAUTION used without the safety alert symbol indicates a potentially hazardous situation which, if not avoided, <b>MAY</b> result in property damage.
As defined in ANSI Z535.4-2002		

## 1.0 Introduction:

**COOL-SPACE®** is patented and a registered Trade Mark of Advanced Radiant Systems, Inc. and manufactured in Indiana.

**COOL-SPACE®** is a compact, self-contained, high-efficiency portable evaporative cooler capable of lowering existing temperatures by as much as 33 degrees.

## 2.0 Unpacking your COOL-SPACE® unit:

### **IMPORTANT**

Carefully examine the carton for damage before opening. If the carton is damaged, notify the shipping company immediately.

The 16" and smaller units are shipped in a cardboard box. Open the top panel and lift the unit out. The larger units are shipped on a wooden skid stapled to a cardboard cover and lid. The cardboard cover simply lifts off the COOL-SPACE® unit after removing the staples. The cooler must be lifted off the wooden skid.

## 3.0 Set-up of the COOL-SPACE unit:

The COOL-SPACE® unit is factory tested and ready to use. The unit should be placed on a level surface, and the casters locked to prevent inadvertent movement. Follow instructions below to connect water and electrical supply.

### 3.1 Connecting the water supply:

The COOL-SPACE® unit comes equipped with a female garden hose water source connection. Attach the unit to a standard garden hose outlet for a water source. It is not recommended that the unit be attached to any water source with operating pressures above 60 psi. A 60 psi pressure reducing valve is installed on your unit. If you have purchased the optional portable water tank, use a standard garden hose (not provided) to connect the tank to the cooler.

**CAUTION**

Do not connect the COOL-SPACE® unit to any water source where water pressure exceeds 60 psi. This will cause permanent damage to the unit.

**3.2 Connecting the electrical supply:**

All models utilize standard 120-volt power supply. The unit should be plugged into a fused or circuit breaker protected 20 amp, 120 volt, 60 Hz circuit. If the unit is for overseas operation or is custom built for a specific application, please consult the factory for proper configuration. A ground fault circuit interrupter protected circuit is strongly recommended.

**IMPORTANT**

The COOL-SPACE® **unit** should be plugged into a fused or circuit breaker protected 20 amp, 120 volt, and 60 Hz circuit. If the unit is for overseas operation or is custom built for specific application, please consult the factory for proper configuration.

If an extension cord is required, refer to Table 2 for the proper 3-conductor heavy-duty cord required. Table 1 shows the amperage requirements for the specific models.

**WARNING**

Do not exceed the extension cord's amperage ratings. Undersized extension cords result in excessive voltage drops, which cause the electric motors to generate excessive heat. This condition results in inefficient motor operation and premature motor failure, WHICH WILL VOID THE WARRANTY.

**Table 1. Electrical requirements for US operation**

CS Model Number	Volts $\pm$ 10%	Frequency (Hz)	Running Amps
16VD	115	60	4.05
361D	120	60	7.2
363B	120	60	9.7
36VD	120	60	7.05
482D	120	60	12.5

**Table 2. Cord size requirement based on length and max amp draw**

Length	Cord Size			
	16 Ga	14 Ga	12 Ga	10 Ga
25	13 A	15 A	15 A	15 A
50	13 A	14 A	15 A	15 A
100	10 A	12 A	13 A	15 A

A-Amps at 125 volt (Derate for lower voltage)

## 4.0 Operating procedures:

There are 3 factors to consider when determining where to place the COOL-SPACE® unit.

1. **Fresh air supply:** The inlet side of the unit (pad side) requires a constant, uninterrupted supply of fresh air for maximum performance. A distance of 3 ft clear space is recommended.
2. **Discharge air flow:** The cool air discharged from the unit should be free of obstruction to allow the air to circulate in order to maximize the cooling zone.
3. **Ventilation:** In order to operate at maximum effectiveness, it is helpful to have provisions to remove the air discharged from the COOL-SPACE® unit from the cooling area. This ensures that the COOL-SPACE® unit does not recirculate air that has already been through the evaporative cooling process.

The COOL-SPACE® unit must be placed on a level surface to operate correctly. The units create an oval shaped air pattern that can reach out as far as 70 feet with large fans. Obstacles such as racks and workbenches may interfere with the cooling zone. An attempt should be made to locate the unit in such a manner that interruption of the air pattern is held to a minimum. Multiple units may be required to cover larger areas.

When the COOL-SPACE® unit is placed near a wall or other vertical obstruction, it is recommended that there be a space of at least 3 feet between the back (pad side) of the unit and the obstruction. This ensures that a clear supply of fresh air is able to get to the inlet of the unit.

A platform or framework may be built to support the COOL-SPACE® unit in order to place the unit out of the way of obstacles. When constructing a framework, ensure that it will not allow the COOL-SPACE® unit to tip over. Also, the structure must be able to accommodate the unit plus the added weight of the water in both the pads and the reservoir.

16"VD Unit: 84 lbs. (unit) + 24 lbs. (pad operating weight) + 120 lbs. (15 gal. reservoir) = 228 lbs.

16"VD-TB Unit: 114lbs. (unit) + 24 lbs. (pad operating weight) + 416 lbs. (52 gal. reservoir) = 554lbs.

36" Unit: 295 lbs. (unit) + 60 lbs. (pad operating weight) + 384 lbs. (48 gal. reservoir) = 739 lbs.

48" Unit: 497 lbs. (unit) + 100 lbs. (pad operating weight) + 512 lbs. (64 gal. reservoir) = 1,109 lbs.

### 4.1 Filling the unit with water:

Once the COOL-SPACE® unit has been hooked up to a water source as described in 3.1, turn the water supply valve on and the unit will fill with water. The float valve will shut off the water flow when the sump is full.



#### 4.2 Starting the fan:

Turn the fan switch to *HIGH* speed on start-up, allow motor to reach maximum speed, then set at *Medium* or *Low*.

#### IMPORTANT

DO NOT flood the pads with water, keep them moist. New pads take a few days to become completely saturated. It is normal to have several dry streaks on the face of the pads about 1 or 2 inches wide. If the streaks are larger or unevenly spaced, adjust the flow control knob to allow more water to flow to the pads. NOTE: New pads may also emanate an odor under initial operating conditions from the resin used to construct the media. Flush the pads by running the pump without the fan running for approximately 2 hours. Empty the sump and refill. Repeat if odor still exists.

#### 4.3 Starting the pump and adjusting the water flow:

NOTE: Have fan running while adjusting the water flow.

Once the sump is full, the pump switch may be turned to the 'ON' position. The flow control knob will need to be adjusted on initial start-up. It is located at the right side of the unit, it controls the volume of water that is delivered to the top of the cooling pads.

#### CAUTION

Prolonged use of hard water without proper water treatment will create mineral deposit build up causing the pump to fail which is "NOT COVERED BY WARRANTY"

#### 5.0 Maintenance and storage:

#### DANGER

#### ELECTRICAL SHOCK HAZARD

Disconnect the power supply before performing any service or maintenance on the unit. Failure to do so may result in serious injury or death.



The COOL-SPACE® unit is constructed of durable industrial grade components and requires minimal maintenance. The housing is constructed of corrosion-free polyethylene. The fan is galvanized for corrosion resistance. The motor is TEAO moisture resistant specifically designed for wet applications. All other components are designed for wet duty applications to ensure long life of the unit.

#### 5.1 Removing the cooling media to access the inside of the unit:

In order to perform any maintenance on internal components, the cooling pads must be removed to access the inside of the unit.

1. Use a wrench to remove the (2) bolts connecting the pad retainer (pad side) to the housing.
2. Each pad can be tilted out of the unit and lifted out of the drain tray.  
Note: Reinstall pads correctly.

### 5.2 Daily maintenance:

When shutting down the COOL-SPACE® unit at the end of each workday, the pump should be turned off approximately 15 minutes before the fan is turned off. This will allow the pads to drain and dry out. This simple guideline will ensure long and efficient pad life as well as help to control mildew and bacteria growth.

#### **IMPORTANT**

Shut off pump 15 minutes before shutting off fan to allow pads to drain and dry out. This will help pad life and operation and control mildew growth.

### 5.3 Periodic maintenance:

Depending on how often the COOL-SPACE® unit operates, this procedure should be performed anywhere from every week for heavy use to monthly for light use. Shut down the unit and drain the water sump. The cooling pads act as a filtering agent and remove dust and other particles from the incoming air stream. These particles will flow into the sump and collect there. Also, impurities in the water will collect in the sump.

1. Close the water flow valve and open the drain valve.
2. Run pump until sump is dry then immediately shut off pump.
3. Turn unit off and disconnect power supply.

#### **WARNING**

#### **ELECTRICAL SHOCK HAZARD**

Disconnect the power supply before performing any service or maintenance on the unit. Failure to do so may result in serious injury or death.



4. Remove cooling pads, refer to 5.1.1.
5. Clean out reservoir with either a towel or wet/dry vacuum.
6. Check belt for tightness, if applicable.
7. Remove the water spray bar, remove its plug. Using pump flush tube and insure holes are free of debris.
8. Reinstall pads and pad retainer.
9. Reinstall back guard (if applicable).

To keep the COOL-SPACE® unit operating at peak efficiency, ensure that the cooling pads are kept clean and dust-free. Dust and other particles have an adverse effect on the media's ability to introduce water into the air stream. If the pad surface becomes dirty or dusty, clean with a soft brush and water.

The fan motor may require periodic lubrication depending on the COOL-SPACE® model. Check your model for an oil fill location on the motor. A few drops of light oil each year will extend motor life.



## 5.4 Storage:

1. Remove the pads, as described in 5.1.1, clean with a soft brush and water to remove dust and debris.
2. Drain sump using above procedure and wipe dry.
3. Store the COOL-SPACE® unit in a dry area and cover if possible to prevent dust build-up.

## 6.0 Troubleshooting/Repair:

### 6.1 Troubleshooting:

#### WARNING

#### ELECTRICAL SHOCK HAZARD



Disconnect the power supply before performing any service or maintenance on the unit. Failure to do so may result in serious injury or death.

The COOL-SPACE® unit consists of three systems, it is important to determine which system of the COOL-SPACE® unit the problem is associated with. This may not always be obvious, in that certain problems may be associated with more than one system.

When determining which system has a problem, you must define associated problem, (*i.e.* the pump is not running). Although this might seem a bit simplified, several things may cause this particular problem. So while defining the problem, a careful check of all systems should be made to fully understand the extent of the problem.

If you have a complete understanding of all of the systems of the COOL-SPACE® unit and how they depend on each other, it will be simple to define and solve any problem.

Although the COOL-SPACE® unit is designed to be simple to maintain, it will be necessary to have some basic hand tools (screwdrivers, pliers, adjustable wrenches, etc.) as well a volt/ohm meter when troubleshooting the electrical system.

### Fan System

#### CAUTION

**Please use caution when troubleshooting or repairing all electrical components. Be certain that all power is disconnected from the COOL-SPACE® unit before the cooling pads or fan guard are removed to gain access to the fan**

### Direct & Belt Drive Models

Problem	Check	Solution
Fan won't run and makes no sound.	Power cord, extension cord, switches, circuit breaker.	Reconnect power or extension cord. Reset breaker.
Fan motor won't run and makes a humming sound.	Blade in contact with shroud. Motor stalled (will not turn by hand).	Re-center blade hub. Replace motor.
Breaker trips or fuse blows when fan is started.	Motor stall. Check power source for min. 115v/20 amp. Extension cord.	Replace motor. Upgrade power supply. Replace with heavier cord.
Motor overheating and shutting off. Restarting several minutes later.	Extension cord gauge too small. Inlet air obstructed or too close to wall. Faulty motor.	Replace with heavier cord. Provide minimum 3' inlet clearance. Replace motor.
Fan motor won't run and switch makes soft clicking sound.	Switch making good contact.	Replace switch.
Fan blade doesn't turn and unit makes squealing sound.	Start capacitor leaking from cover. Motor stall (as above). Fan belt, loose or broken. Fan pulley spinning on shaft.	Replace capacitor. Replace motor. Tighten or replace fan belt. Tighten pulley set screw.
Fan belts do not last very long.	Motor and fan pulleys alignment.	Realign motor and mount.
Fan will not reach speed but turns and makes humming sound.	Capacitor (where visible) and motor electrical connections. Extension cord too small.	Replace capacitor or motor. Increase cord gauge.

## Water System

The water delivery system consists of three primary elements: 1) Water Distribution System, 2) Spray Bar Assembly, 3) Pump, Troubleshooting of this system is fairly simple.

The water Distribution System consists of two assemblies: A) The Water Inlet Assembly, B) The Hose & Valve Assembly.

The Water Inlet Assembly is made up of three components: 1) The brass bulkhead fitting, 2) The float valve connection hose, 3) The float valve assembly.

The Hose & Valve assembly consists of three elements: 1) Spray Bar Assembly, 2) Valve Assembly, 3) Connection hose.

## Water System

Problem	Check	Solution
Floor at side of COOL-SPACE® unit is wet	Water inlet hose is loose at supply hose or inlet hose is loose at bulkhead fitting.	Tighten connections and/or replace hose washers.
COOL-SPACE® unit overflows from reservoir or is spitting water through fan.	Float valve hose is loose at bulkhead fitting or at float valve. Water pressure is too high to allow float valve to shutoff (60psi max). Float valve is not seating properly.	Tighten connections and/or replace hose washers. Reduce water pressure by adding an inline reducer. Check float valve. Replace float orifice.
Water spitting from the unit.	Cracked Hose & Valve Assembly.	Replace Hose & Valve Assembly.
Water leaking from drain valve.	For worn washer, worn stem. Make sure drain valve is closed.	Replace washer. Replace drain valve.
Water leaking from water flow control valve.	Washer worn. Stem worn. Jam nut loose.	Replace water flow control valve. Tighten Jam nut.
Too many dry streaks in the pads.	Holes in spray bar blocked. Adjust water flow.	Remove spray bar. Remove plug and clean tube and holes. Open water flow control valve.
Water spitting from the unit.	Hose connection loose. Faulty hose. Flooding of pads.	Tighten hose. Replace hose and washer. Adjust water flow control valve.

## Pump

Problem	Check	Solution
Pump motor will not run when switch is turned on.	Turn fan on to check for power. Is water level high enough to make the low-water cut-off circuit.	If fan doesn't start; check breaker and cord plug-in. If fan does start; check for power to and through pump switch (when turned on). Fill water reservoir.
Pump motor hums when switch is turned on, but does not pump water.	Obstruction in impellar. Pump motor failure.	Remove object(s). Replace pump.
Pump makes loud noise while running.	Object(s) in impellar, impellar loose. Pump bearings bad.	Remove object(s). Replace pump.
Breaker trips or fuse blows when switch is turned on.	Check power cord length and breaker rating. Check for locked-up pump.	Refer to pg. 5 for unit amperage draw and pg. 6 to determine required cord gauge. Replace pump.
Pump won't run and power is available. Pump is functional.	Make certain switch is working. Is water level high enough to make the low-water cut-off circuit.	Replace switch if not completing circuit. Fill water reservoir.
Pump runs but does not pump water.	Air lock in outlet side of pump. Make certain impellar is turning in pump.	Turn off and on to bleed. If not, replace pump.

### 6.2 Repair procedures:



#### CAUTION

**Repairs should be performed by a qualified technician!**

**Warning: Care must be taken to avoid electrical shock when servicing.  
DISCONNECT POWER WHEN SERVICING.**

### Fan Motor Replacement

#### **Belt Drive Models (see section 5.1 for pad removal)**

1. Remove the motor wiring plate and disconnect motor wires. Mark each wire with a marker that will allow easy matching when new motor is installed.
2. Loosen the four bolts that fasten the motor to the bracket. This will allow the removal of the motor.
3. Remove the motor pulley by loosening the set screw and slide the pulley off.
4. Install the pulley onto the new motor and slightly tighten the set screw.
5. Place new motor onto the mounting bracket and reinstall the four mounting bolts and tighten.

6. Visually align the motor pulley and fan pulley by using the belt as a reference. Adjust the motor pulley in or out to align. Tighten the motor pulley.
7. Loosen the four bolts that secure the mounting bracket to the upright.
8. Lower the bracket slightly until the belt is tight (but not tight enough to overload the motor) and then tighten the four bracket bolts.
9. Replace the motor wires as marked from step # 5. Replace wire ties to prevent cord from getting in fan blade.
10. Replace motor wiring cover plate and inspect to be certain that the rubber seal is properly seated.
11. Replace cooling pads and guards and reconnect power and test motor.

### **Face Mounted Direct Drive Models**

- 1.) Remove the motor wiring plate and disconnect motor wires. Mark each wire with a marker that will easily allow matching when new motor is installed.
- 2.) Remove fan guard and fan blade.
- 3.) Loosen the four nuts that secure the motor to the motor braces. This will allow the removal of the motor.
- 4.) Place new motor in position and reinstall the four mounting nuts and tighten.
- 5.) Reattach the fan blade onto the motor shaft and tighten the set screws being sure that the motor shaft extends the same distance beyond the blade hub.
- 6.) Check that the motor and fan assembly turns freely, and fan blade does not strike the motor supports.
- 7.) Replace the motor wires as marked from step #1. Replace wire ties to prevent cord from getting in the fan blade.
- 8.) Replace motor wiring cover plate and inspect to be certain that the rubber seal is properly seated.
- 9.) Replace cooling pads and guards and reconnect power and test motor.

### **36" Variable Speed Direct Drive Models**

- 1.) Remove cap off rear of motor. Disconnect wires. Clip wire ties.
- 2.) From the front, remove 4 fan mounting bolts. (Support fan to ensure it doesn't fall.)
- 3.) With fan out of unit remove cap on blade to access blade mounting nut. Remove nut and blade.
- 4.) Remove mounting arms by loosening 8 nuts and slide arms out of slot. (Make note of arms position for reinstallation.)
- 5.) Install arms and blade or new motor.
- 6.) Install fan in opening and install mounting bolts.
- 7.) Reconnect wires and tie cord to motor arm to keep them out of fan.

## **Pump Replacement**

- 1.) Disconnect hose from pump.
- 2.) Remove pump bracket.
- 3.) Disconnect wiring from pump switch. (Note: Units built after 03-11 unplug from top of pump by removing 2 screws.)

- 4.) Remove pump from water sump and install new pump. Reverse the above procedures to reconnect the wiring, lift pump bracket and reconnect the hose. Secure wires to fan frame with wire ties to clear the fan blades.
- 5.) Reinstall cooling pads and guards, reconnect power and test pump.

### **6.3 Technical support:**

Technical support and service is available directly from your distributor or COOL-SPACE® Technical Support Hot Line at 1-800-557-5716.

### **7.0 Warranty:**

Under normal use, the Warranty covers (12) twelve months on the pump and (24) twenty-four months from date of invoice for the remaining components. Refer to the manufacturer's Warranty Policy for details.

### **7.1 Warranty Form:**

Fill out and return to manufacturer. Supplied with unit.

### **7.2 Warranty parts:**

Warranty replacement parts are available through your local Distributor or Supplier where you purchased your COOL-SPACE® unit. If you have any questions or concerns, please contact us direct at 1-800-557-5716 or at [sales@cool-space.com](mailto:sales@cool-space.com). Please have your **model number** and **serial number** ready.

**DO NOT DISCARD FAULTY PARTS! THEY WILL NEED TO BE RETURNED FOR WARRANTY CREDIT.**

### **7.3 Optional accessories:**

Accessories are available from your local Distributor or Supplier or can be found online at [www.COOL-SPACE.com](http://www.COOL-SPACE.com).

## 7.4 Common Replacement Parts

### Fan Motor

<b>CS-F16 (Motor/Shroud/Fan Combo)</b>	<b>16" Variable Speed</b>
<b>CS-M162</b>	<b>16" Two Speed</b>
<b>CS-M162-1 (CS2 Series)</b>	<b>16" Two Speed</b>
<b>CS-M361 (Face Mount)</b>	<b>36" Single Speed</b>
<b>CS-M361-AC (Base Mount)</b>	<b>36" Single Speed</b>
<b>CS-M363B</b>	<b>36" Three Speed</b>
<b>CS-M36V</b>	<b>36" Variable Speed</b>
<b>CS-M482B</b>	<b>48" Two Speed</b>

### Switches

<b>CS-E110</b>	<b>On/Off Pump &amp; Single Speed Fan</b>
<b>CS-E111</b>	<b>Two Speed</b>
<b>CS-E115</b>	<b>Three Speed</b>
<b>CS-E185</b>	<b>Variable Speed</b>

### Pump

<b>CS-E163-2</b>	<b>16", 36" &amp; 48"</b>
------------------	---------------------------

### 8" Pads

<b>CS-H610</b>	<b>16" (2 Required)</b>
<b>CS-H613</b>	<b>36" (5 Required)</b>
<b>CS-H48-140</b>	<b>48" (6 Required)</b>

### Float Assembly

<b>CS-P052 (Before 08/09)</b>	<b>16", 36" &amp; 48"</b>
<b>CS-P053.1 (After 08/09)</b>	<b>16", 36" &amp; 48"</b>
<b>CS-A131 (After 01/11)</b>	<b>16", 36" &amp; 48"</b>



# 8.1: CS5-16-2D / CS5-48-2D - WIRING SUB-ASSEMBLY

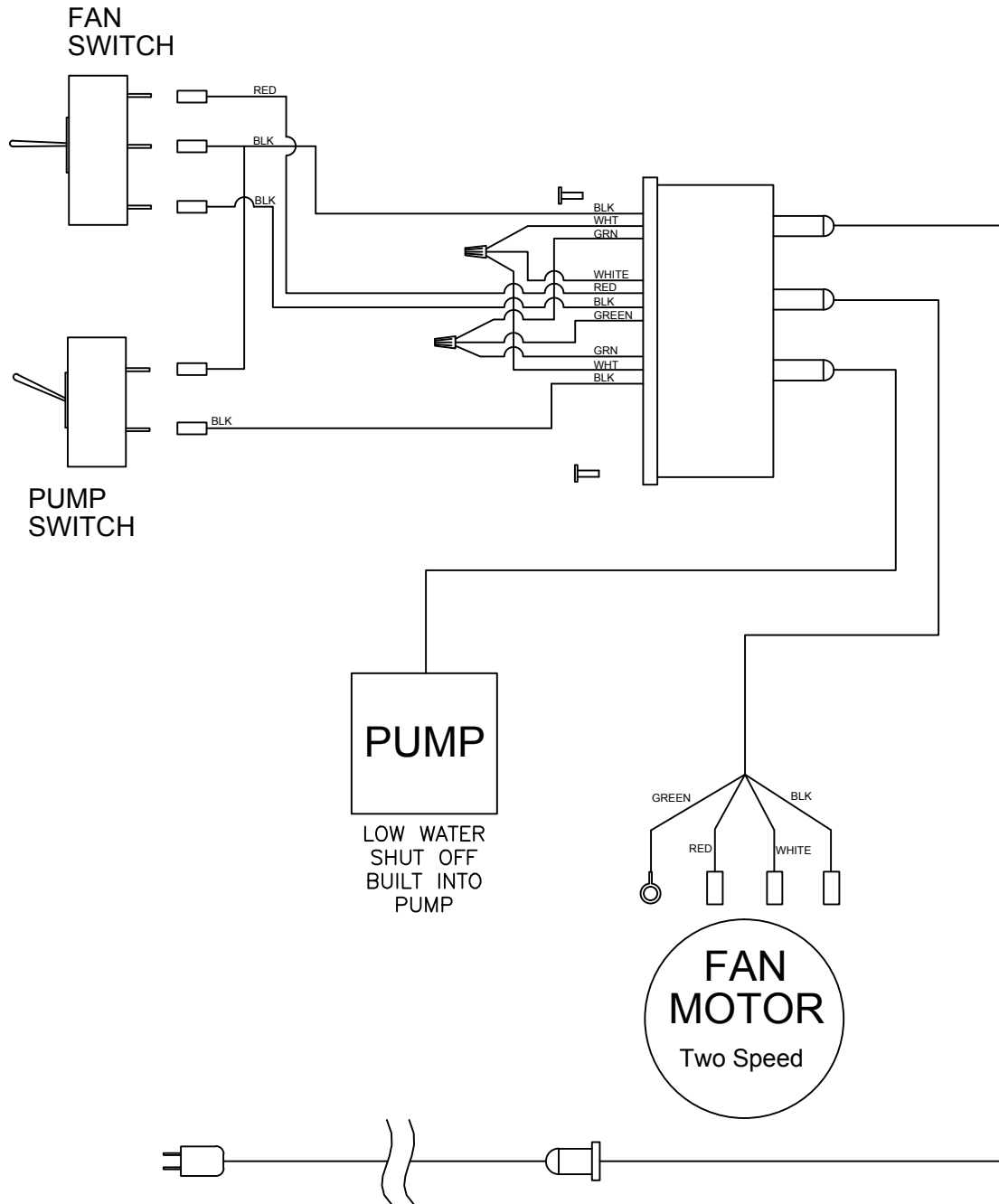

Assy. No. CS-A580	Revised 03-14
----------------------	------------------

## 8.2: CS5-36-1D / CS6-36-1D - WIRING SUB-ASSEMBLY

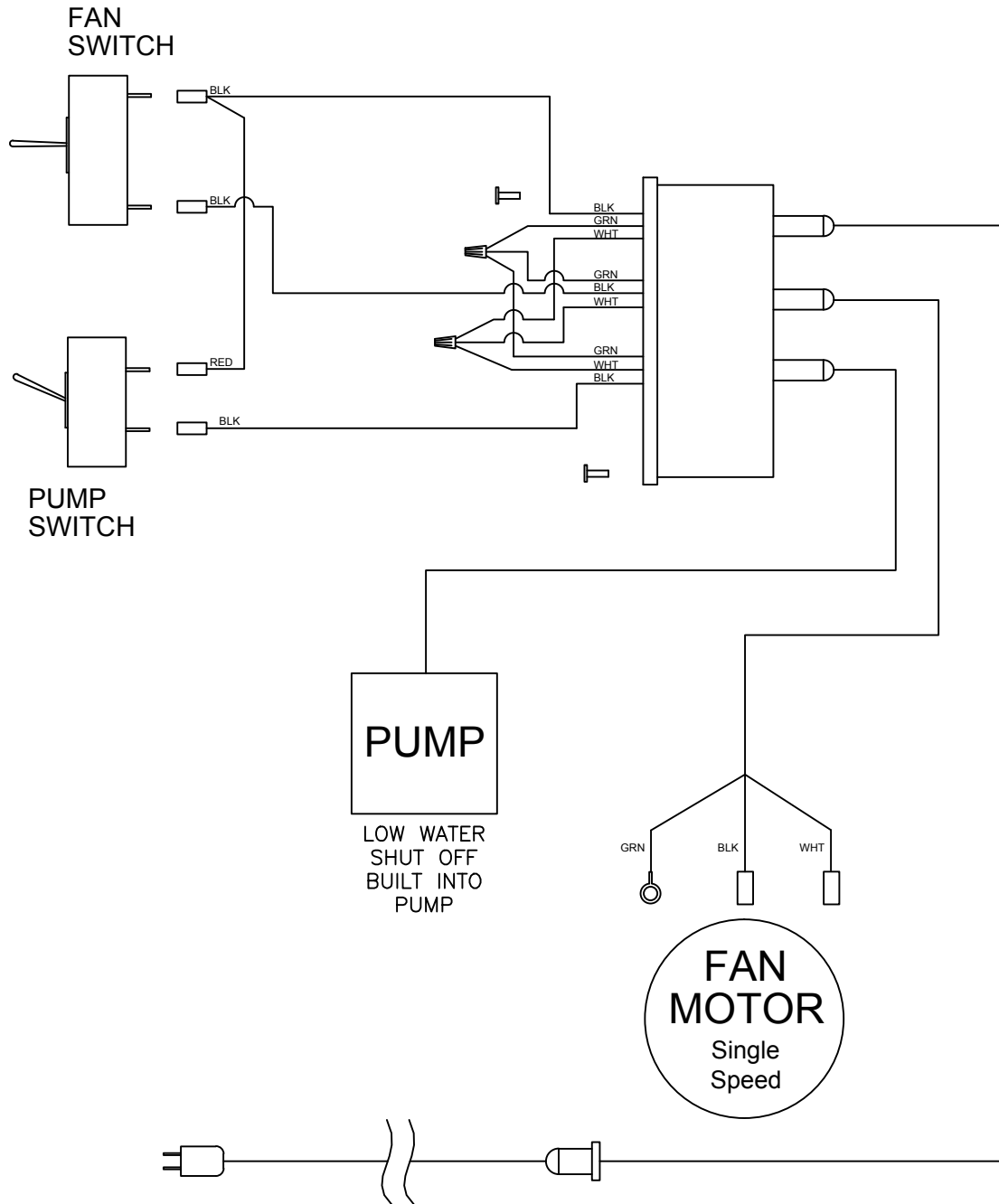

Assy. No.  
CS-A580

Revised  
03-14

# 8.3: CS5-36-3B / CS6-36-3B - WIRING SUB-ASSEMBLY

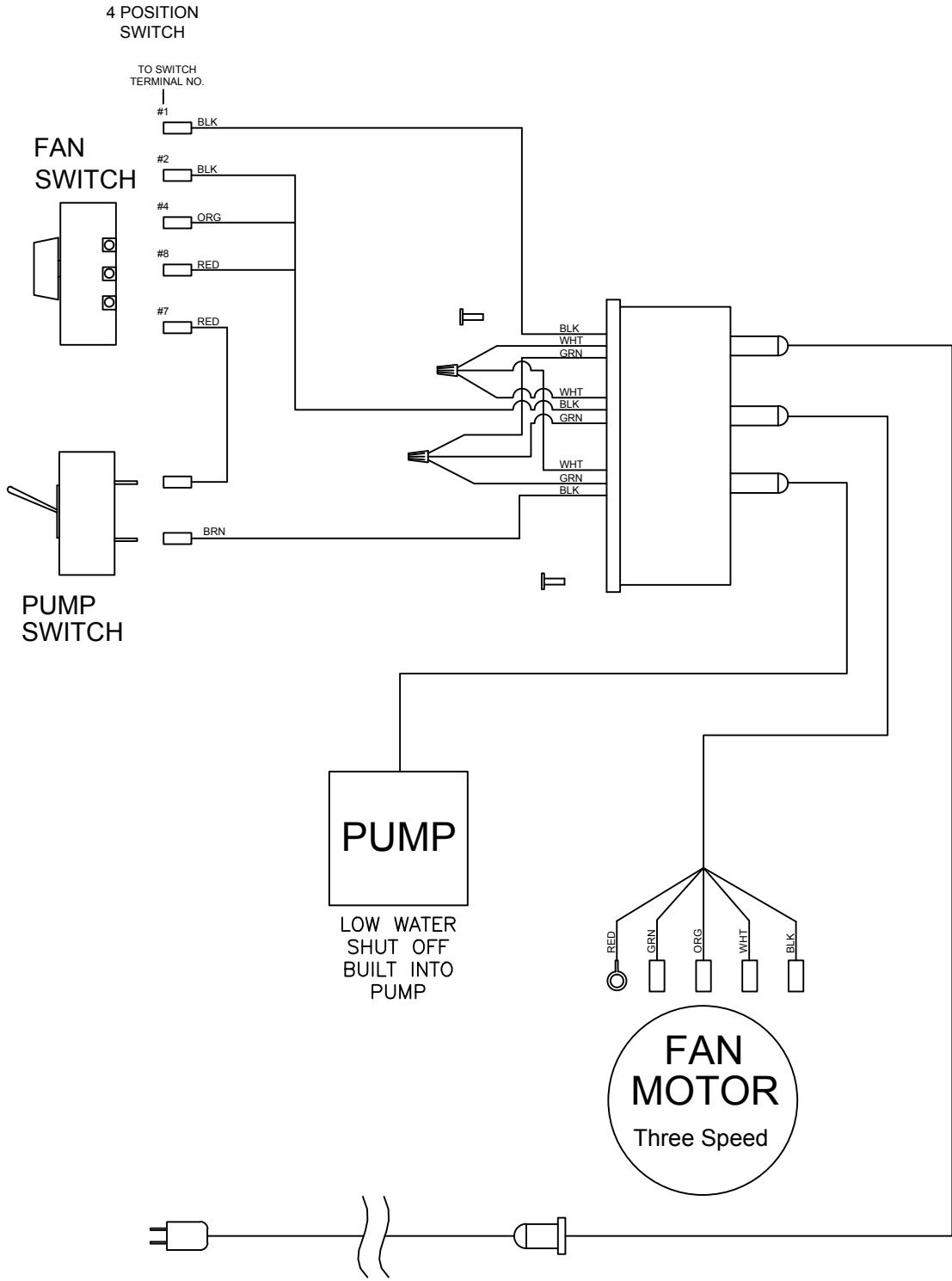

Assy. No. CS-A580	Revised 03-14
----------------------	------------------

## 8.4: CS5-16-VD / CS5-16-VD-TB / CS5-36-VD / CS6-36-VD - WIRING SUB-ASSEMBLY

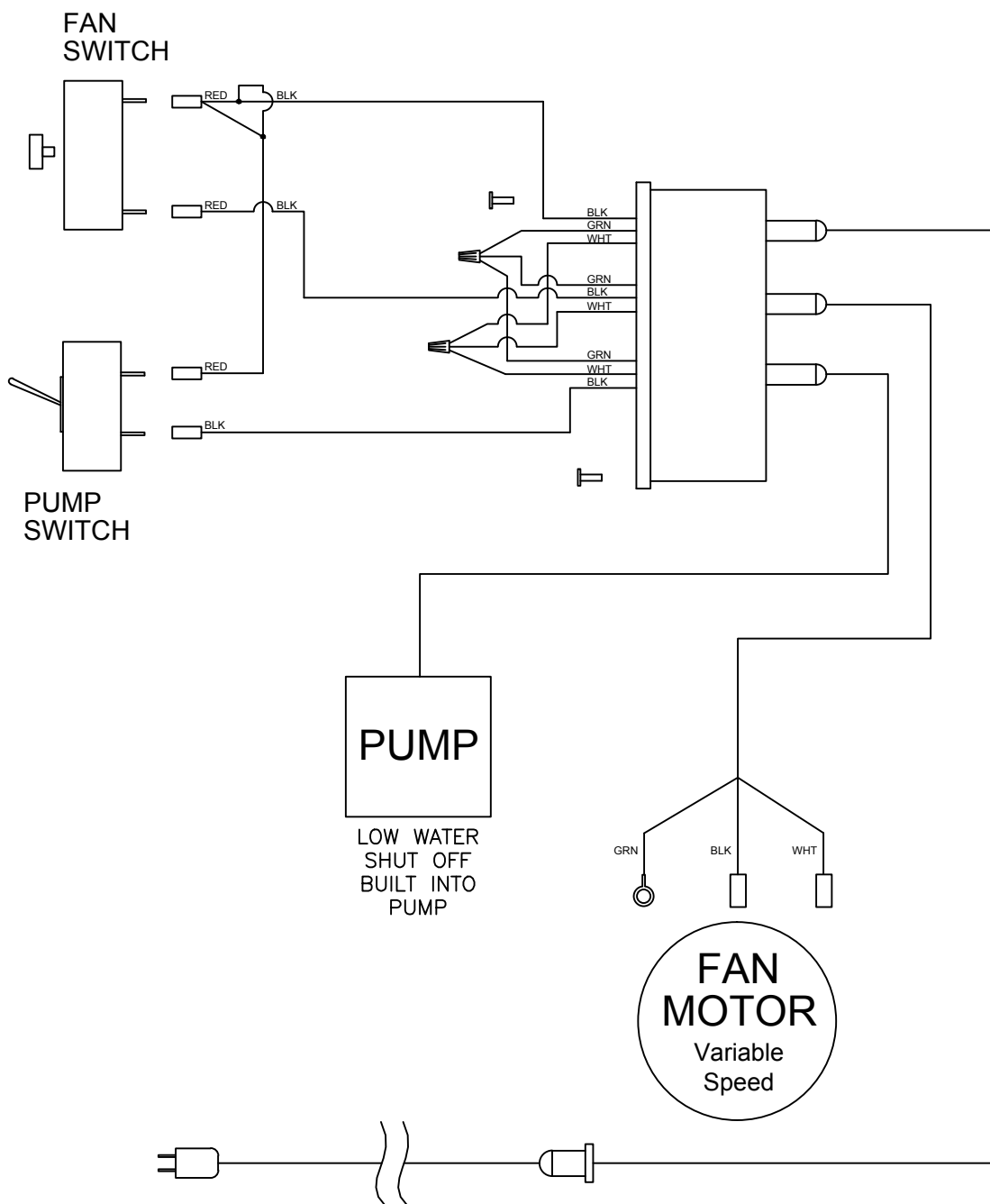

Assy. No.  
CS-A580

Revised  
03-14

## 9.0 How evaporative cooling works:

In order to have an understanding of how the COOL-SPACE® portable evaporative cooler works a basic understanding of psychrometrics is necessary. Psychrometrics is the branch of thermodynamics devoted to the study of air and water vapor mixtures. The psychrometric chart is a graphical representation of properties of moist air. To illustrate how the COOL-SPACE® unit operates, some of the relevant properties are described in this section followed by a sample application.

*Dry-bulb temperature* is measured with thermometer. *Dry-bulb temperature* lines in psychrometric chart are the vertical line Figure 1.

**Figure 1.**

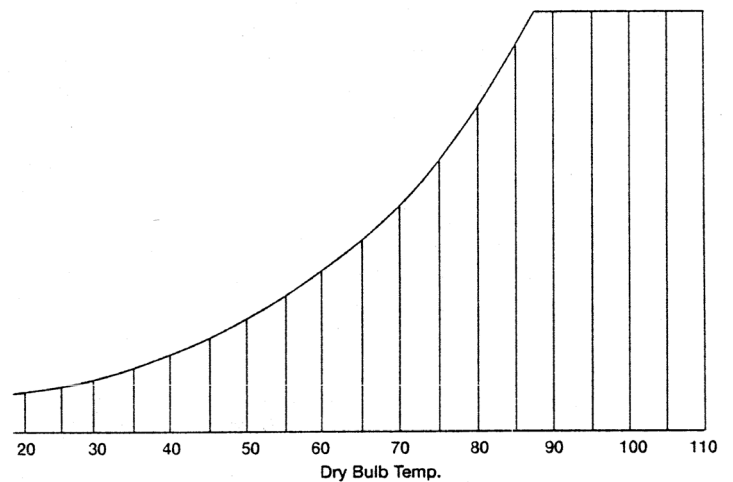

*Wet-bulb* temperature is measured using a wet-bulb thermometer, which is an ordinary liquid-in glass thermometer whose bulb is enclosed by a wick moistened with water, often called a sling psychrometer. The psychrometer is whirled around in the air. If the air is not saturated (100% relative humidity), the water in the wick evaporates and the water temperature falls below the *dry-bulb* temperature. Figure 2 shows the *wet-bulb* temperature lines on the psychrometric chart.

**Figure 2.**

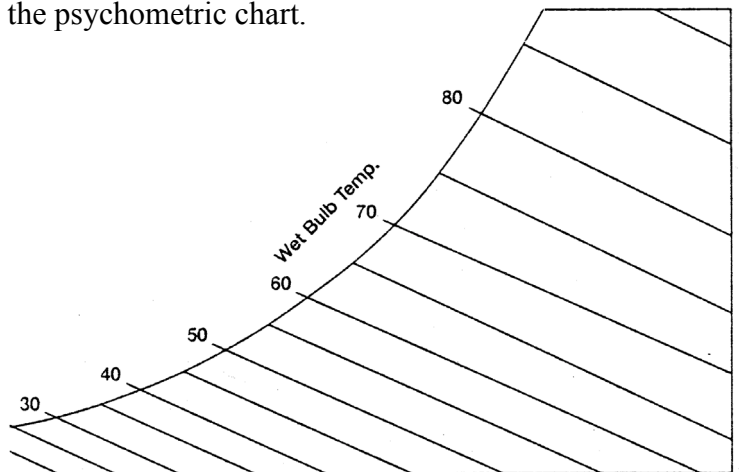

*Dew-point temperature* is the temperature to which a given sample of air must be cooled so that moisture will start condensing out of it. When air is saturated, the *dry-bulb*, *wet-bulb* and *dew-point* temperatures will all be equal. The horizontal lines in Figure 3 show the *dew-point temperature* on the psychrometric chart.

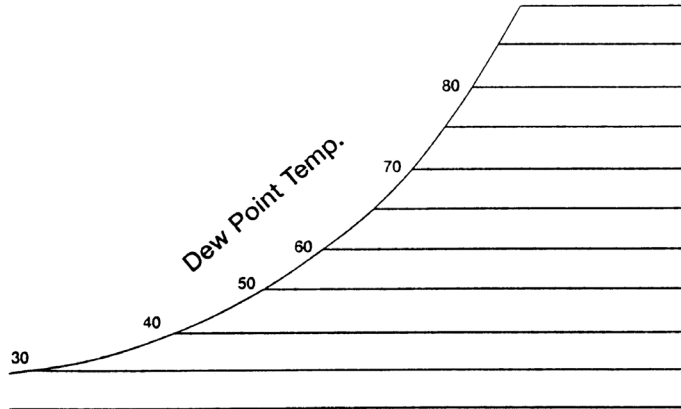

**Figure 3.**

*Relative humidity* is the amount of moisture in the air relative to the amount of moisture the air would hold if saturated at that *dry-bulb temperature*. Percent humidity is not the same as *relative humidity* and is not used in HVAC design. Figure 4 shows the *relative humidity* curves on the psychrometric chart.

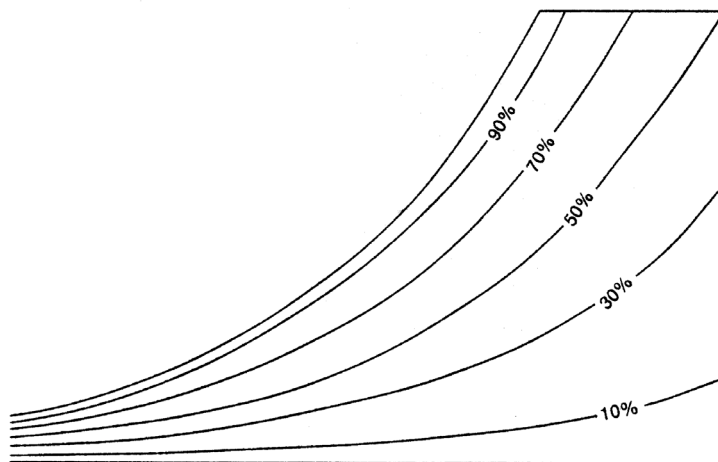

**Figure 4.**

The following example illustrates the use of the psychrometric chart as it relates to evaporative cooling. Since all of the items described above are properties, any two of them describe a state point on the psychrometric chart. Once this point is determined, the values of all the other properties can be read from the chart. Figure 5 below shows a Mollier type psychrometric chart for atmospheric pressure.

The dot shown in Figure 5 is a state point. The following properties are known about the air/water mixture at this state.

*dry-bulb temperature: 97°F*  
*wet-bulb temperature: 78°F*

*dew-point temperature: 71°F*  
*relative humidity: 43%*

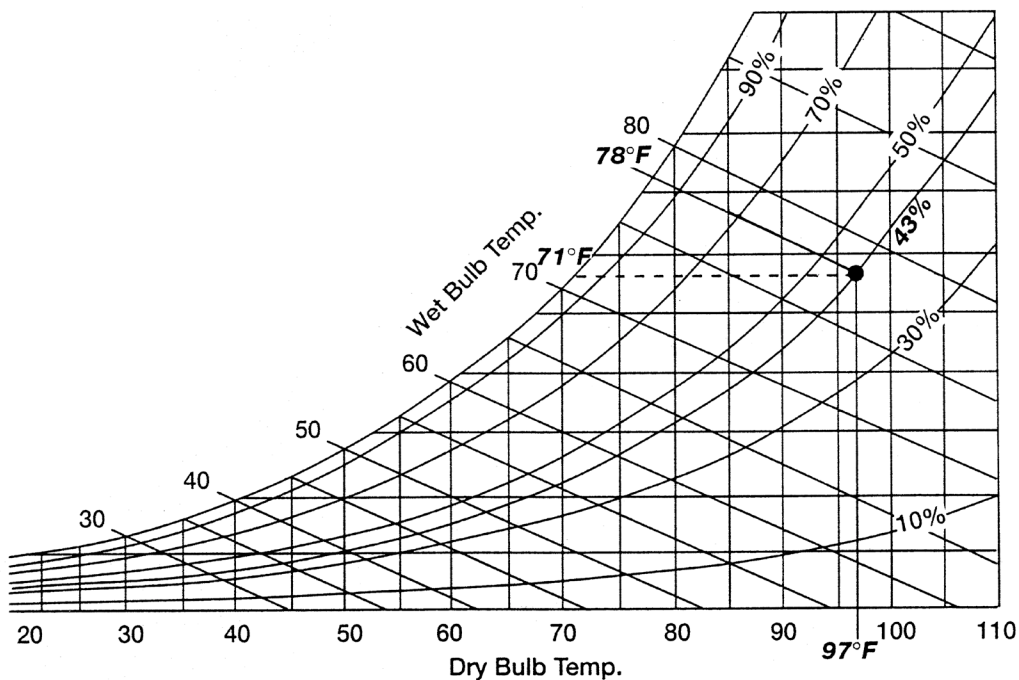

The COOL-SPACE® unit is a high-efficiency portable evaporative cooler. The unit draws air across water saturated high-efficiency cooling pads which forces the air to evaporate the water, thus removing energy from the air.

Take the air/water mixture described by the state point above, with a dry-bulb temperature of 97°F and 43% relative humidity, for example. As the air passes through the cooling media on the

COOL-SPACE® unit, moisture is added to the air increasing the relative humidity. This increase in relative humidity brings a decrease in dry bulb temperature. When the relative humidity is raised to 70%, the dry bulb temperature has dropped to 86°F. When the humidity level approaches 100%, the dry bulb temperature has dropped nearly 20°F to 78°F.







PORTABLE EVAPORATIVE COOLERS

A Division of



Advanced Radiant Systems, Inc.  
Phone: 317-577-0417 – Fax: 317-485-0118

**1-800-557-5716**  
**[www.cool-space.com](http://www.cool-space.com)**  
**[sales@cool-space.com](mailto:sales@cool-space.com)**