

SPECIFICATIONS

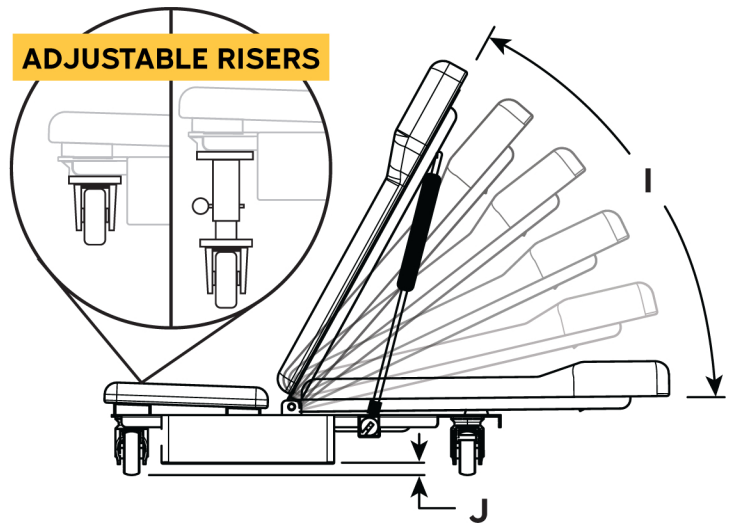
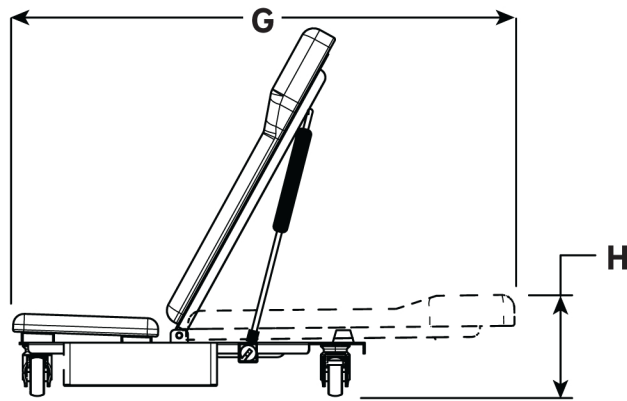
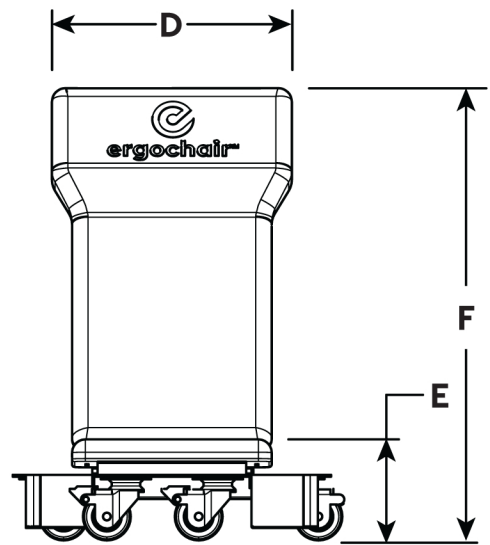
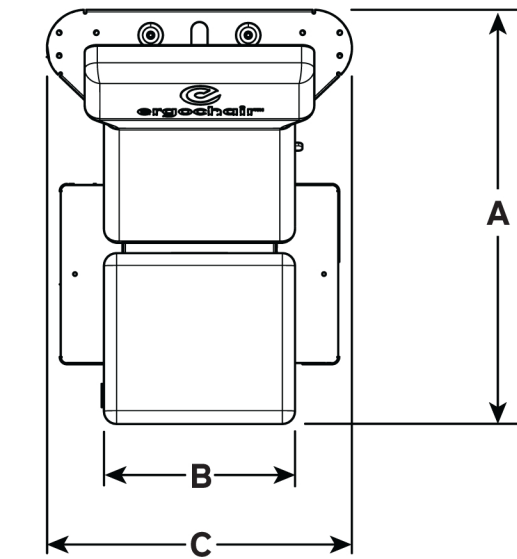

A	Length (backrest up)	32 in. (813 mm)
B	Seat Width	14.75 in. (376 mm)
C	Max. Width	23.5 in. (600 mm)
D	Headrest Width	17.75 in. (451 mm)
E	Seat Height	* 6.75 in. (175 mm)
F	Height (backrest up)	* 31.5 in. (800 mm)
G	Length (backrest down)	45.75 in. (1,160 mm)
H	Height (backrest down)	* 9.5 in. (241 mm)
I	Backrest Angle	≈5° to ≈60°
J	Ground Clearance	* 1.6 in. (41 mm)

Ergo-Scout Weight: 87 lbs. (39.5 kg.)

Backrest Adjustment Angle: 0° to ≈60°

Backrest Locking Mechanism: Gas Spring

Casters: Four 360° Casters (2 locking), Ø75 mm x 25 mm, sleevebearings, oil resistant, non-marking rubber wheels

Seat Materials: Padded Marine Vinyl Backrest and Seat. Marine Vinyl is abrasion, chemical and oil resistant

Frame Materials: Full powder coated, welded tubular steel

Tool Box Inside Dimensions:
13.75 x 4.6 x 3.75 in. (349 x 117.4 x 95.2 mm)

Riser Kit Adds : ≈8 to 12 in. Max. (200 to 300mm max.)

* Measurements exclude risers