

INSTALLATION & OPERATION MANUAL



Atlas PV-15PX 15,000 lb. Capacity Two-Post Overhead Lift



Atlas Automotive Equipment
www.atlasautoequipment.com
(866) 898-2604

Model: PV15
Revised: 09/29/23

CONTENTS

Product Features and Specifications	3
Installation Requirement	5
Installation Steps	7
Exploded View	32
Test Run	36
Operation Instruction	38
Maintenance	39
Trouble Shooting	40
Warranty	41

I. PRODUCT FEATURES AND SPECIFICATIONS

CLEAR-FLOOR DIRECT-DRIVE MODEL FEATURES

Model PV15 (See Fig. 1)

- Direct-drive design minimizes the lift wear parts and breakdown ratio.
- Dual hydraulic cylinders, designed and made to high standards, utilizing imported oil seals in the cylinder.
- Self-lubricating UHMW Polyethylene slide blocks and bronze bushings.
- Single-point safety release with dual safety design.
- Clear-floor design provides unobstructed floor use.
- Overhead safety shut-off device prevents vehicle damage.



Fig. 1

MODEL PV15 SPECIFICATIONS

Model	Style	Lifting Capacity	Lifting Time	Lifting Height	Overall Height	Overall Floor Width	Width Between Columns	Minimum Pad Height	Motor
PV15	Clear-floor Direct-drive	5.5 T/ 12000 LBS	55S	72 1/2" - 81 1/2"	165"/177" 150"*	150 3/4"	123 1/2"	7 1/4"	2.0HP

***SPECIAL LOW HEIGHT SETTING REQUIRES PURCHASE OF EXTRA CABLES**

**Arm Swings View
For Model PV15**

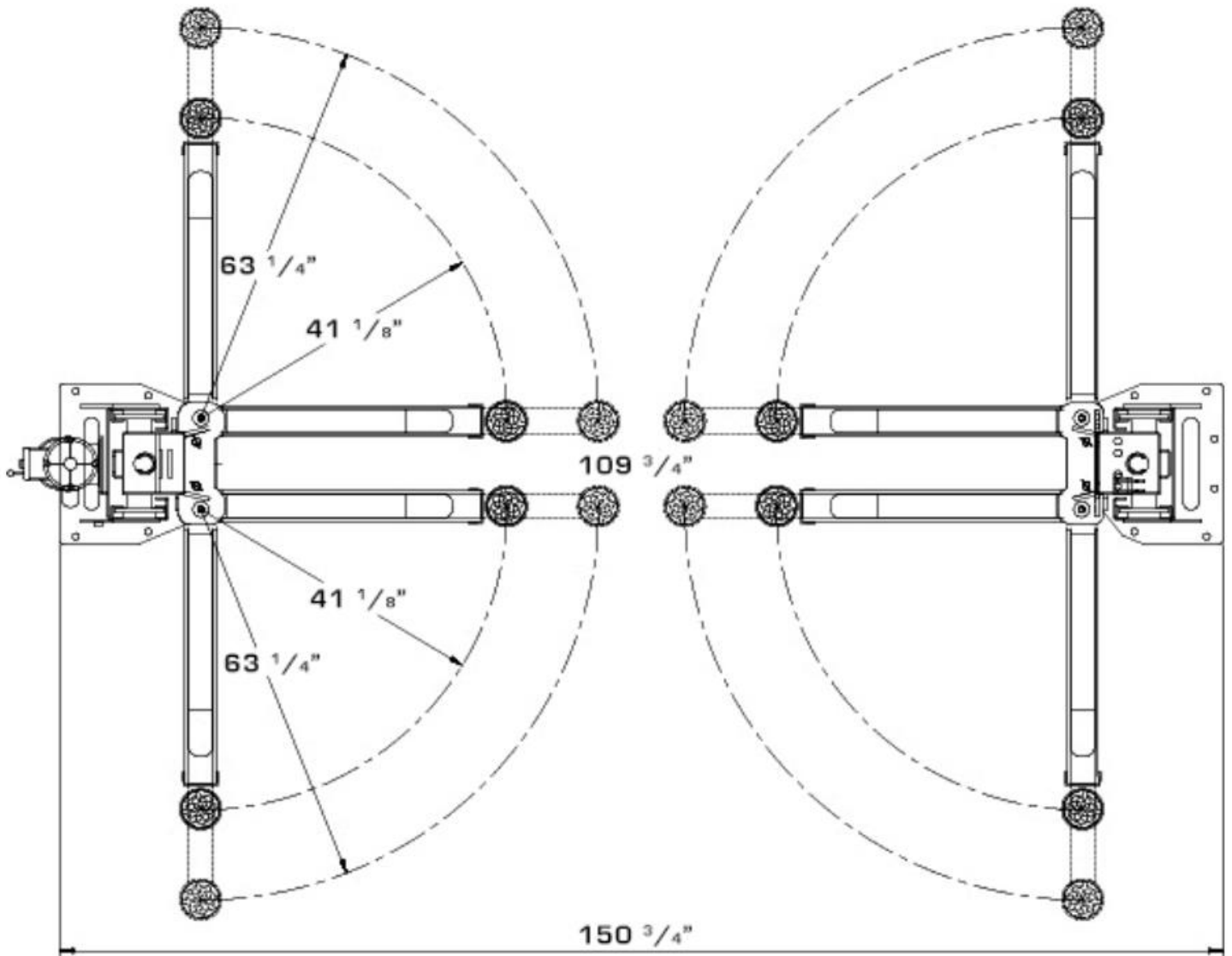

Fig. 2

II. INSTALLATION REQUIREMENT

A. TOOLS REQUIRED

- ✓ Rotary Hammer Drill (3/4" bit)



- ✓ Hammer



- ✓ Level Bar



- ✓ Crescent Wrench (12")



- ✓ Ratchet with Socket (28mm)



- ✓ Wrench set

(10#, 13#, 14#, 15#, 17#, 19#, 24#, 27#, 30#,)



- ✓ Carpenter's Chalk



- ✓ Screw Drivers



- ✓ Tape Measure (25 FT)



- ✓ Pliers



- ✓ Allen Wrenches (3mm, 5mm, 8mm)



- ✓ Vise Grips



Fig. 3

B. Equipment storage and installation requirements.

The equipment should be stored or installed in a shady, moderately temperate, ventilated and dry place.

C. The equipment should be unloaded and transferred by forklift.

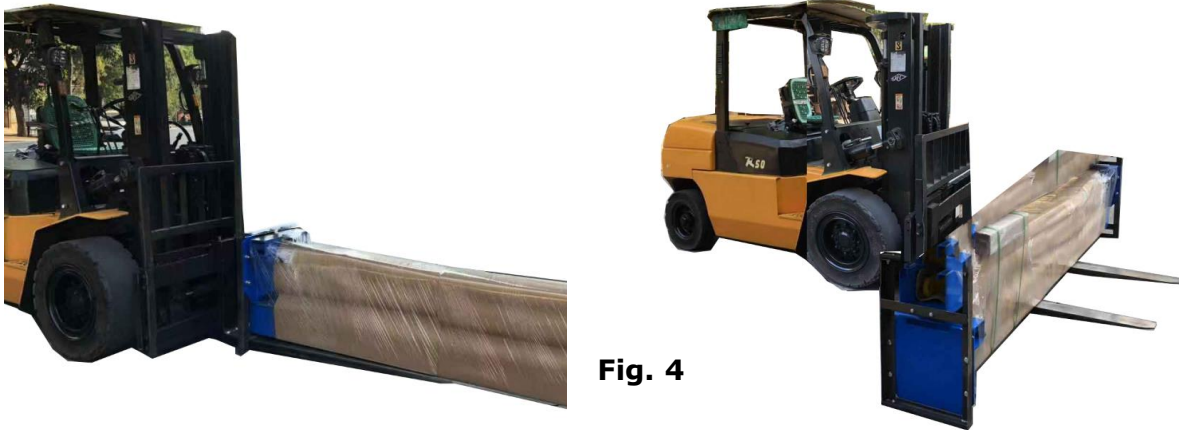

Fig. 4

D. SPECIFICATIONS OF CONCRETE (See Fig. 5)

Concrete specifications must be followed accordingly.

WARNING: Failure to do so may result in lift and/or vehicle falling.

1. Concrete must be 6 inches minimum thickness, without reinforcing steel bars, and must be completely cured before lift installation.
2. Concrete must be in good condition and must be of test strength of 3,000psi (210kg/cm²) minimum.
3. Floors must be level with no cracks or holes.

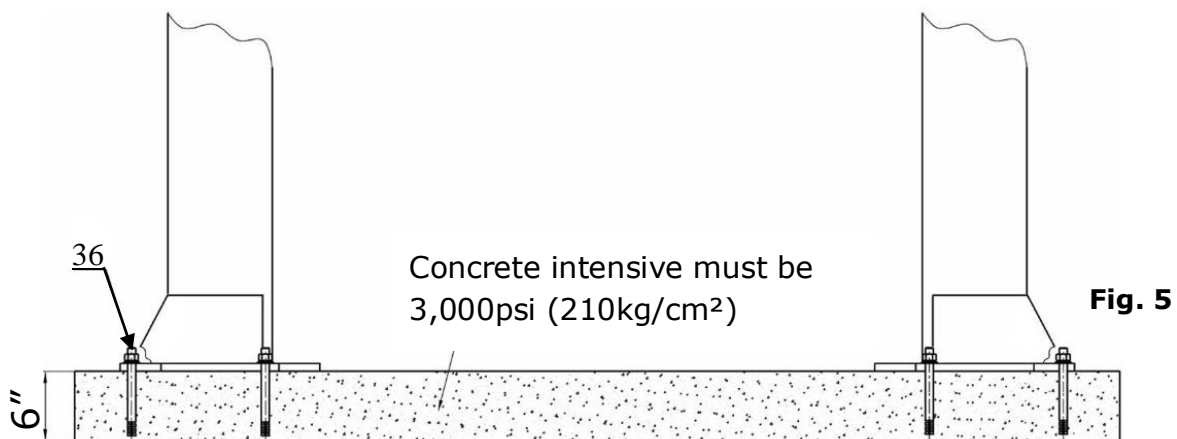

E. POWER SUPPLY

220 volt single phase motor on a 30 amp breaker with minimum of 10 gauge wire.
Operating voltage range is 208v-230v.

III. INSTALLATION STEPS

A. Location of installation

Check and ensure the installation location (concrete, layout, space size etc.) is suitable for lift installation.

B. Use a carpenter's chalk line to establish installation layout of baseplate.

(See Fig. 6)

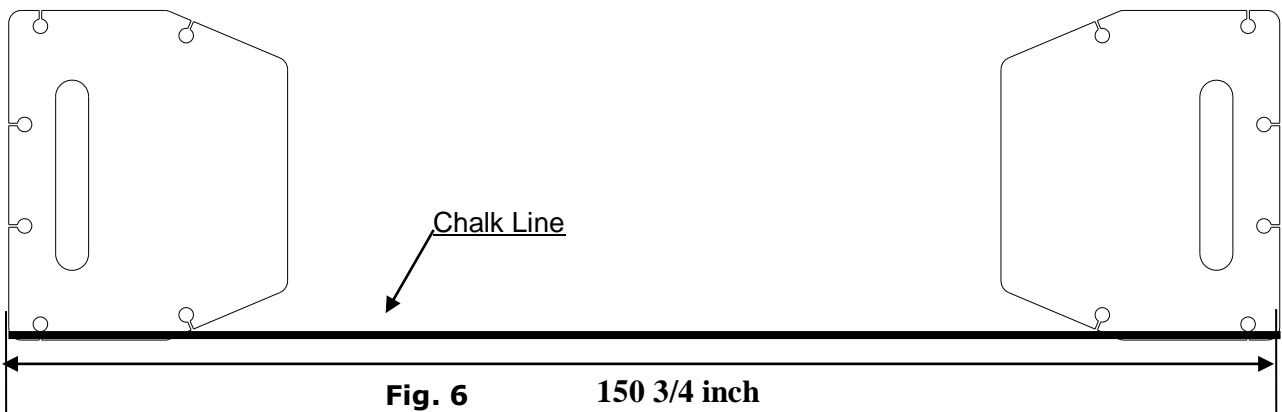

C. Check the parts before assembly.

1. Packaged lift and hydraulic power unit (See Fig. 7).



2. Move the lift aside with a forklift or hoist, and open the outer packing carefully and move aside the top connecting assy. and parts box

(See Fig. 8).

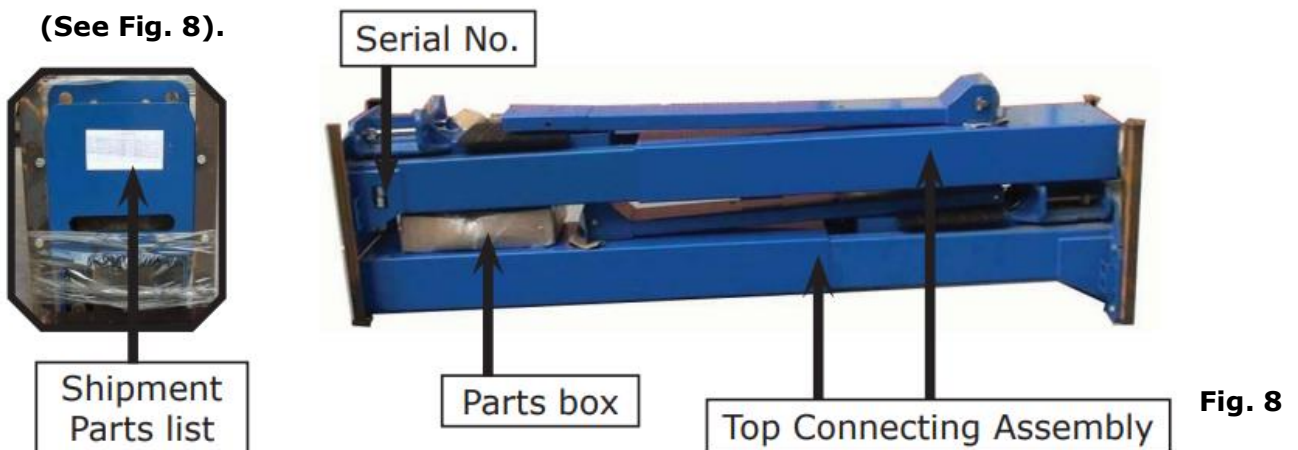

3. Lift the upper column with a forklift or hoist and loosen the bolts on the upper package stand. Remove the upper column and take out the parts in the bottom column. **(See Fig. 9)**



Fig. 9

4. Lift the lower column with a forklift or hoist, remove the package stand, then take off the lower column and remove the parts from the inner column **(See Fig. 10).**

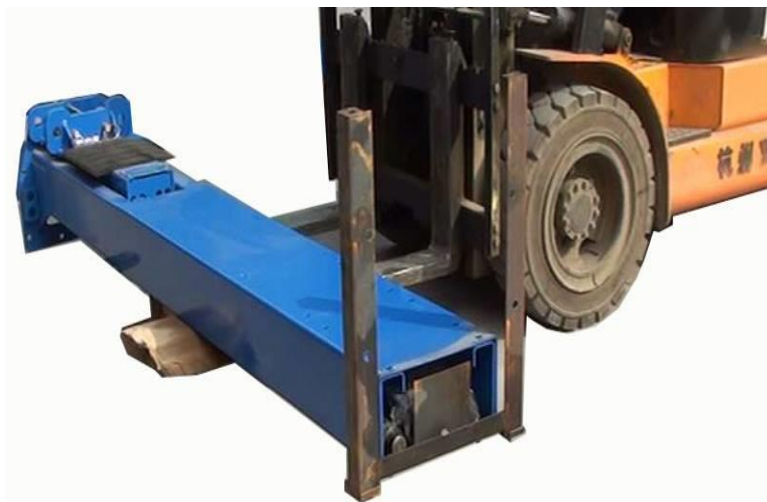
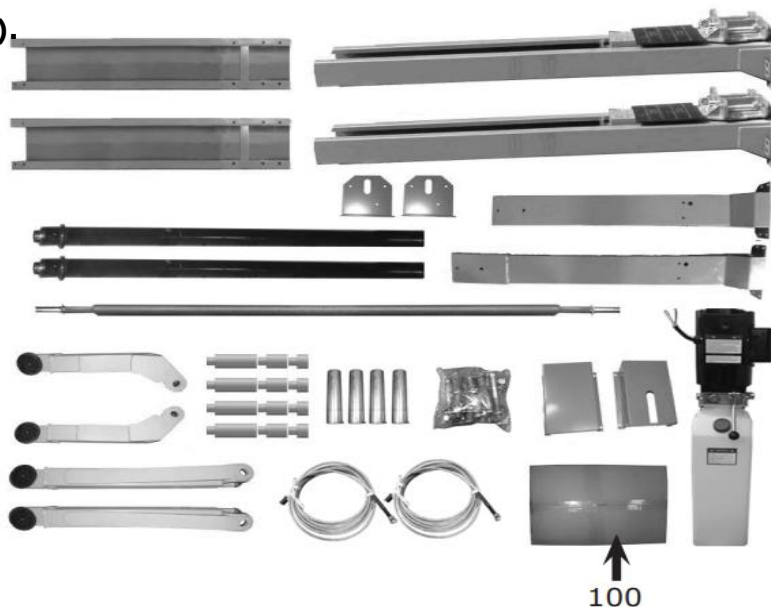

Fig. 10

5. Move aside the parts and check the parts according to the shipment parts list. **(See Fig. 11 & Fig. 12).**



**Shipment parts list
Fig. 11**

100

D. Install the hydraulic hose and lock release cable brackets on extension columns (See Fig. 15).

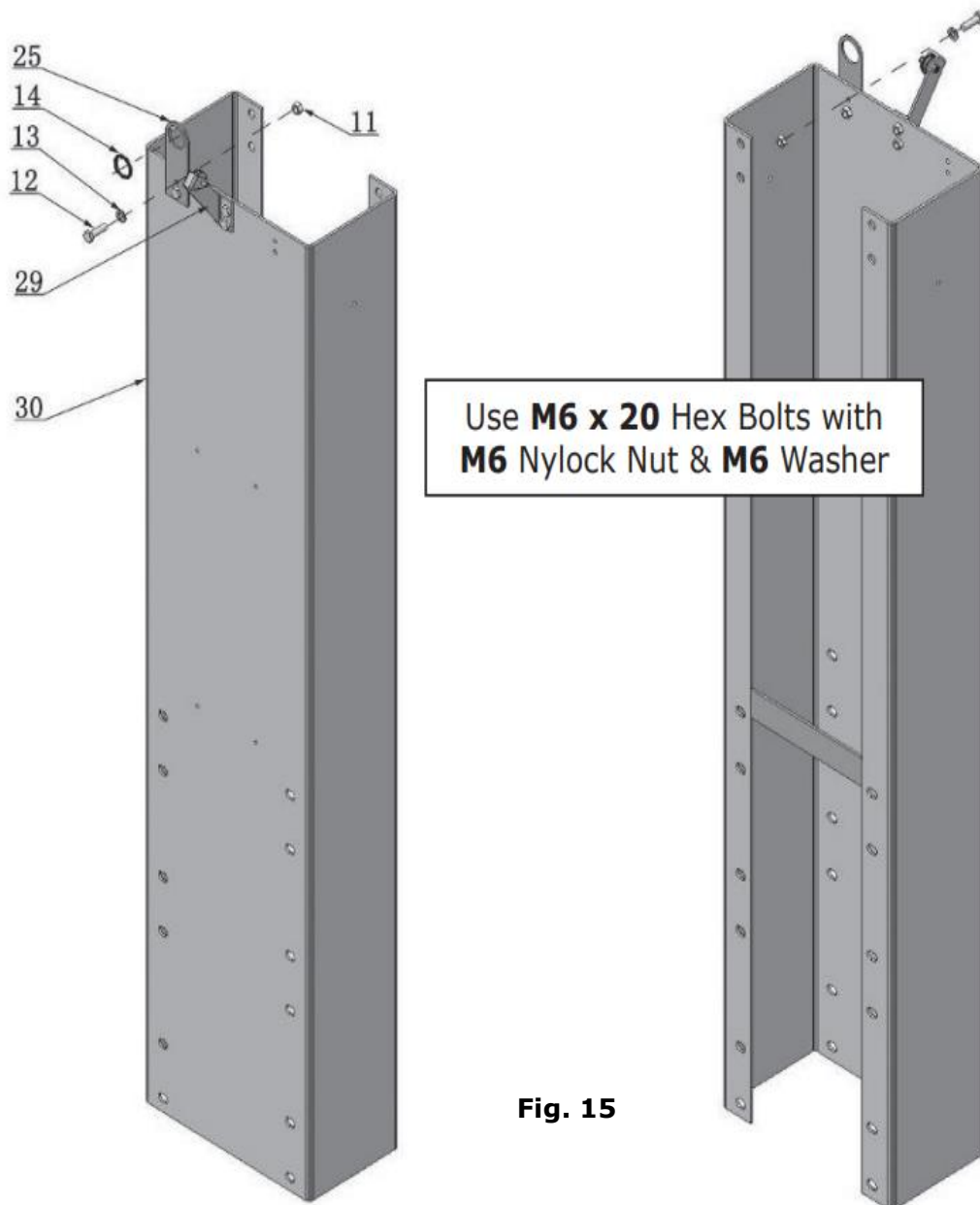
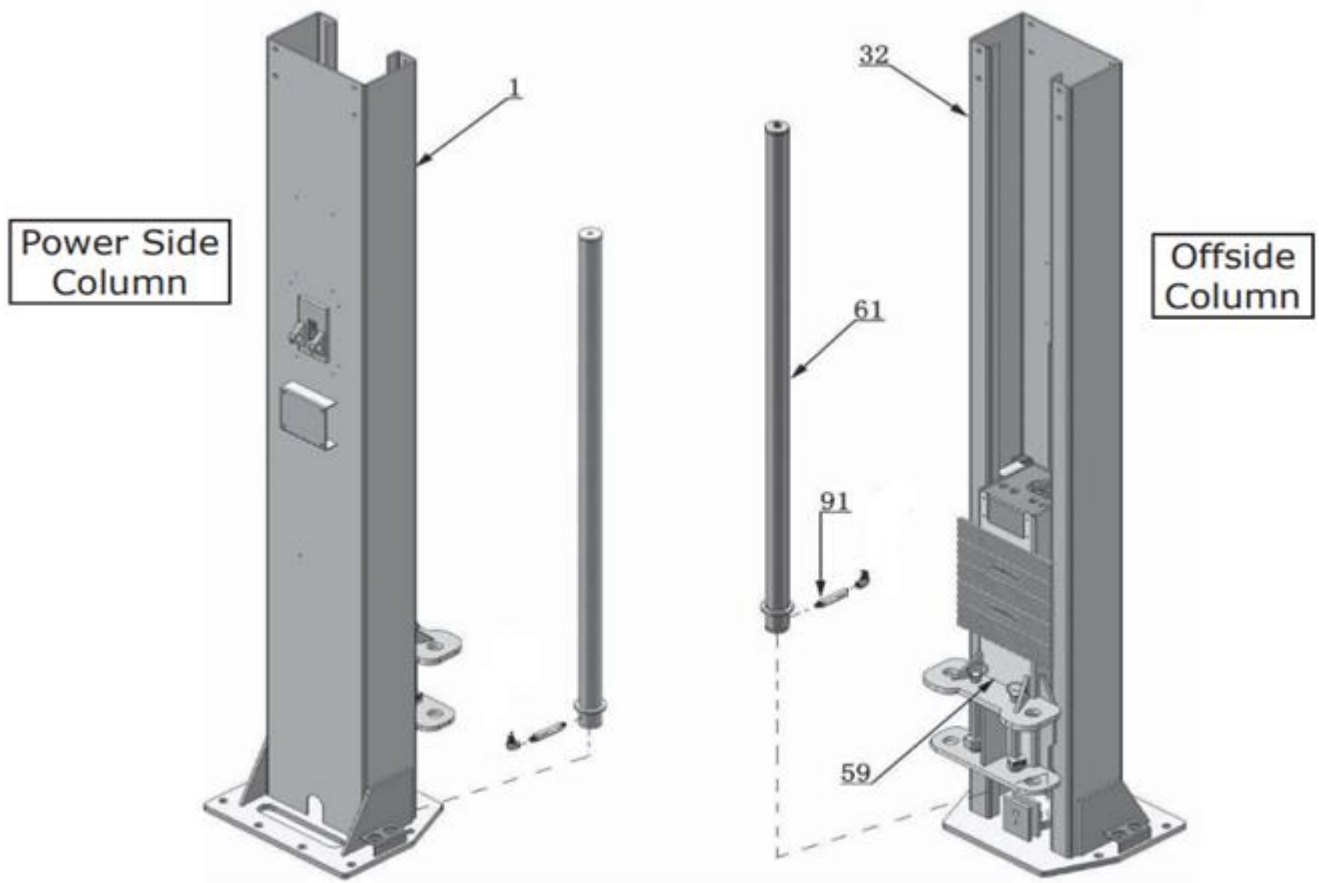

Fig. 15

E. Install hydraulic cylinder

Wrap both ends of straight fittings with white Teflon tape, install straight fitting in each cylinder (See Fig. 16).



Use Teflon tape to seal pipe threads.
Do not use teflon tape on hydraulic hose ends.

The fitting of the cylinder
toward the hole of the column

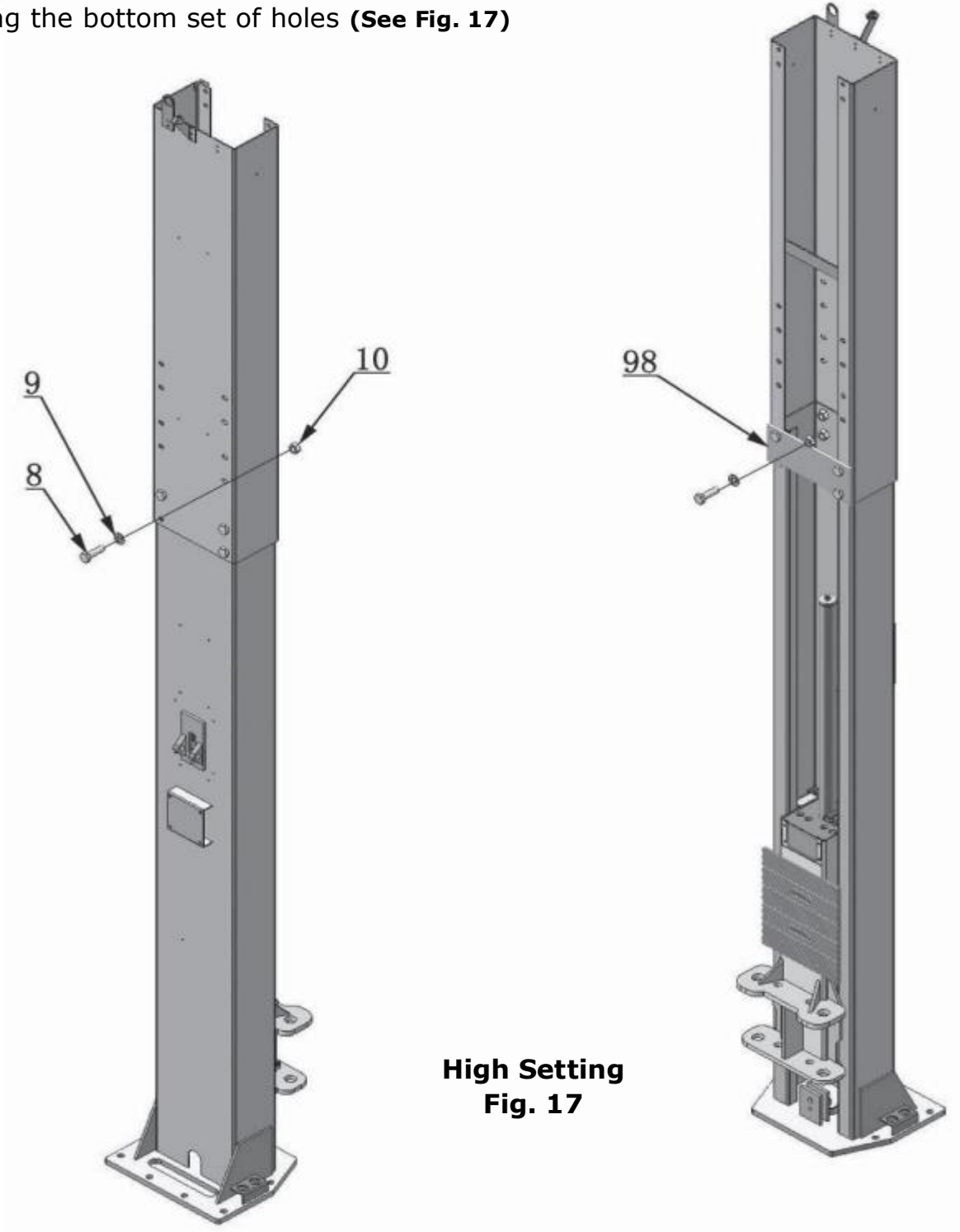

Fig. 16

F. Install columns

Lay down the columns on the installation site parallel to each other. Position the power side column according to the installation site. This lift is designed with 2-section columns. Adjust lift height according to the ceiling height and connect the inner and extension columns.

1. When the ceiling height is over 177 1/8", connect the extension columns using the bottom set of holes (**See Fig. 17**)



**High Setting
Fig. 17**

2. When the ceiling height is over 165 3/8" but is less than 177 1/8", connect the extension columns using the middle set of holes (See Fig. 18)

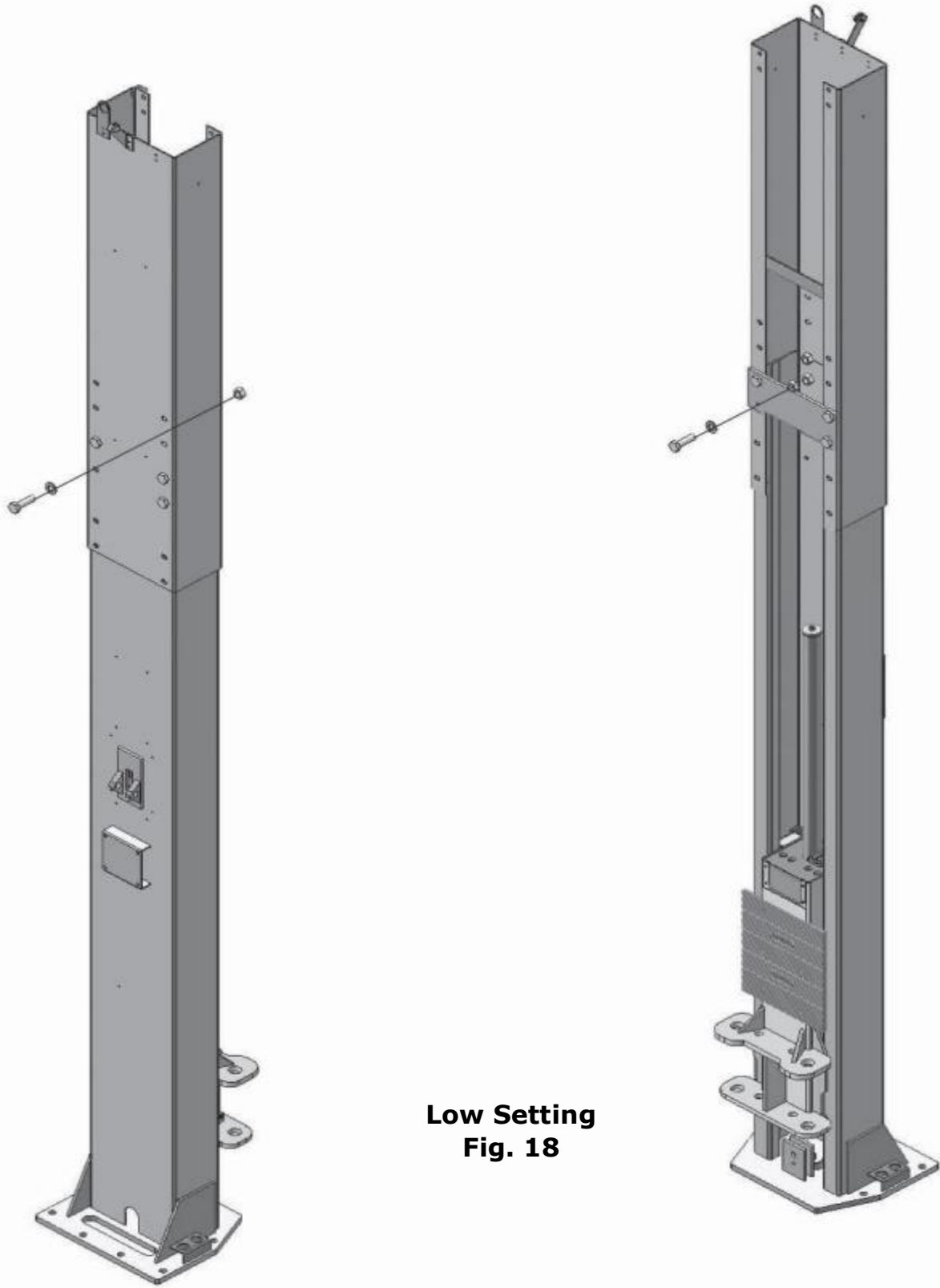

3. When the ceiling height is less than 165 3/8", connect the extension columns using the top set of holes (See Fig. 19)

NOTE: THIS SETTING REQUIRES THE ADDITIONAL PURCHASE OF SHORTER CABLES

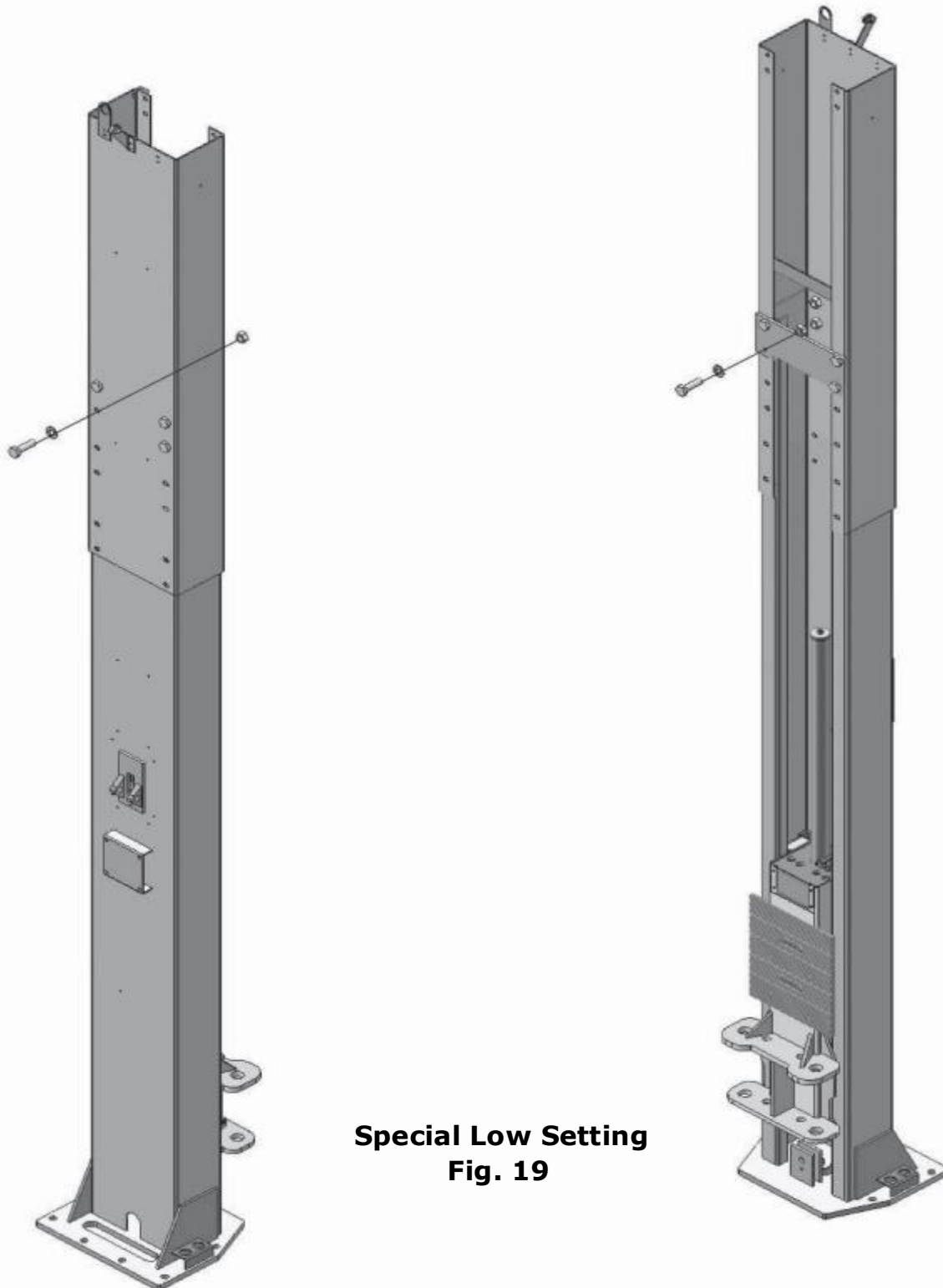

**Special Low Setting
Fig. 19**

G. Position the columns

Position the columns so the base plates line up with a chalk line. Position the offside column parallel to the power side column at the approximate width of 122 5/8". Install the overhead cross beam. Level and plumb the columns, shim where necessary. Drill 3/4" anchor holes. If the top of the anchor exceeds 2 inches above the floor grade, you **DO NOT** have enough embedment, tighten the anchor bolts to 125 Ft Lbs.

Do not drill holes for anchor bolts until overhead cross beam has been installed.

(See Fig. 20)

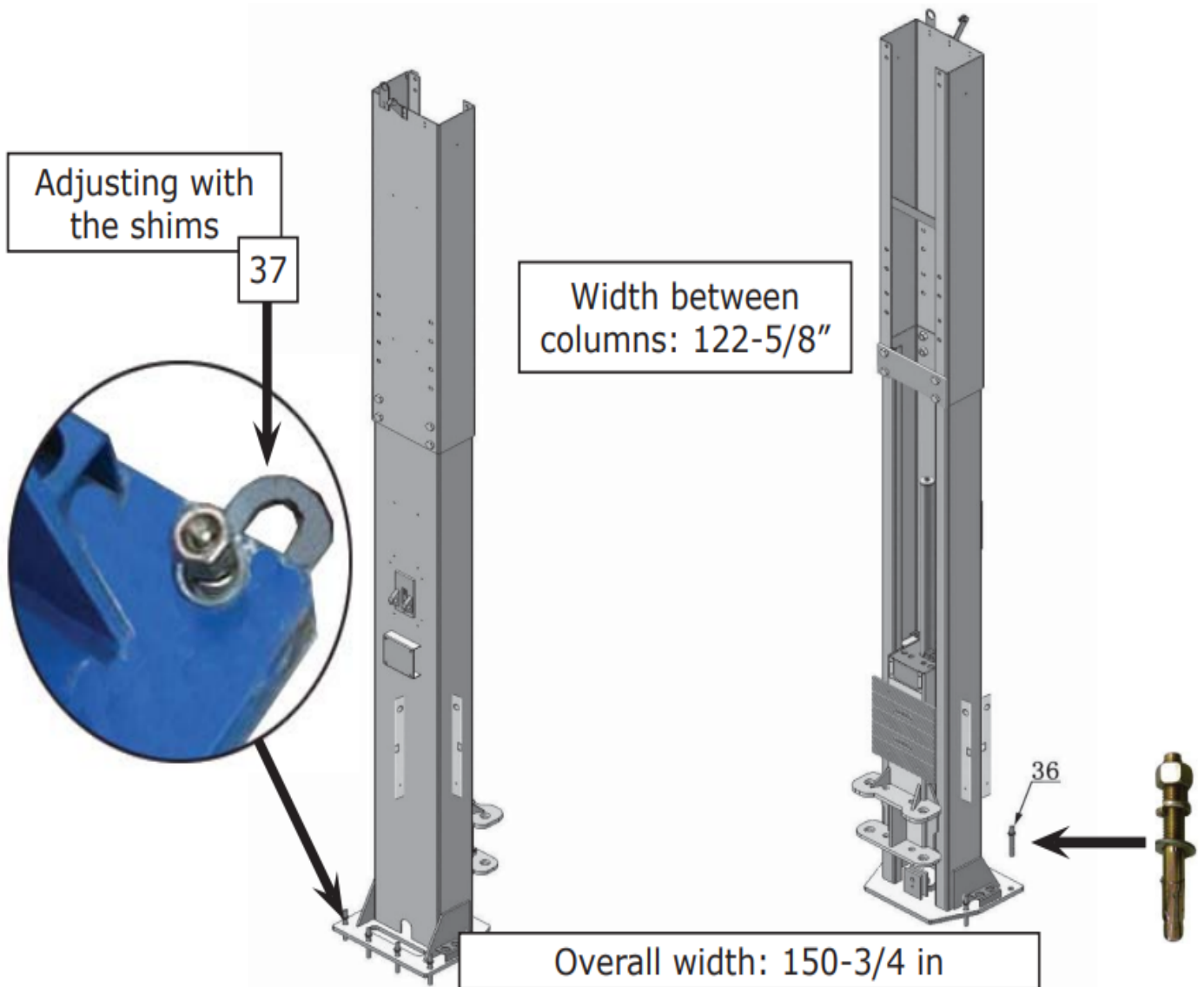
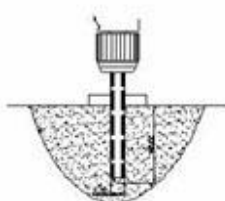
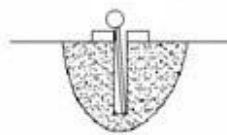

Fig. 20



Drilling



Cleaning

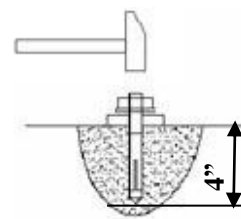

Bolting

H. Install overhead top beam

1. With help of the hook of top beam, put one side of top beam on top of the extension column and connecting the top beam to extension column by bolts, tighten the bolts. (See Fig. 21).

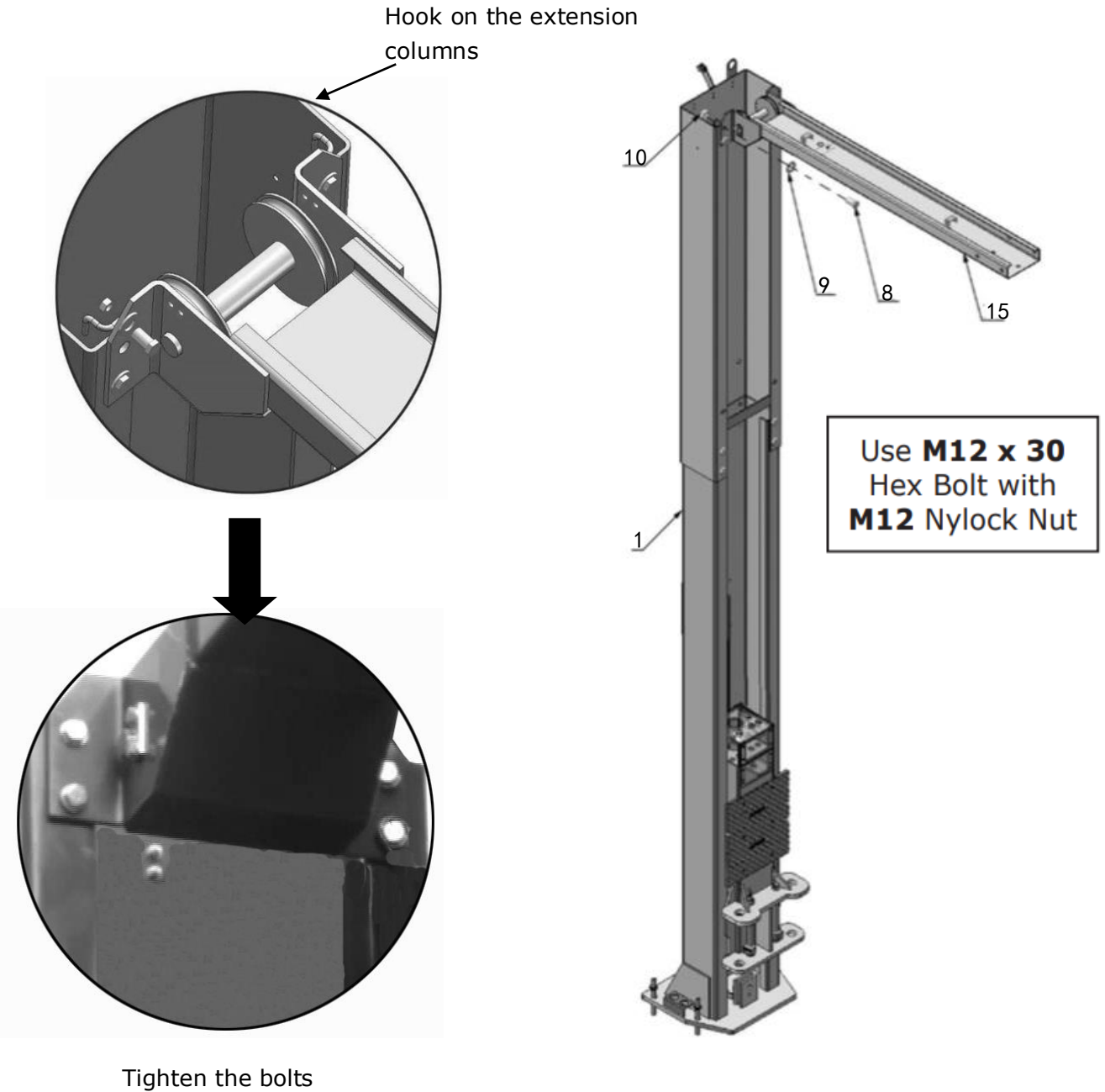

Fig. 21

2. Assemble overhead top beam: tighten the anchor bolts (See Fig. 22).

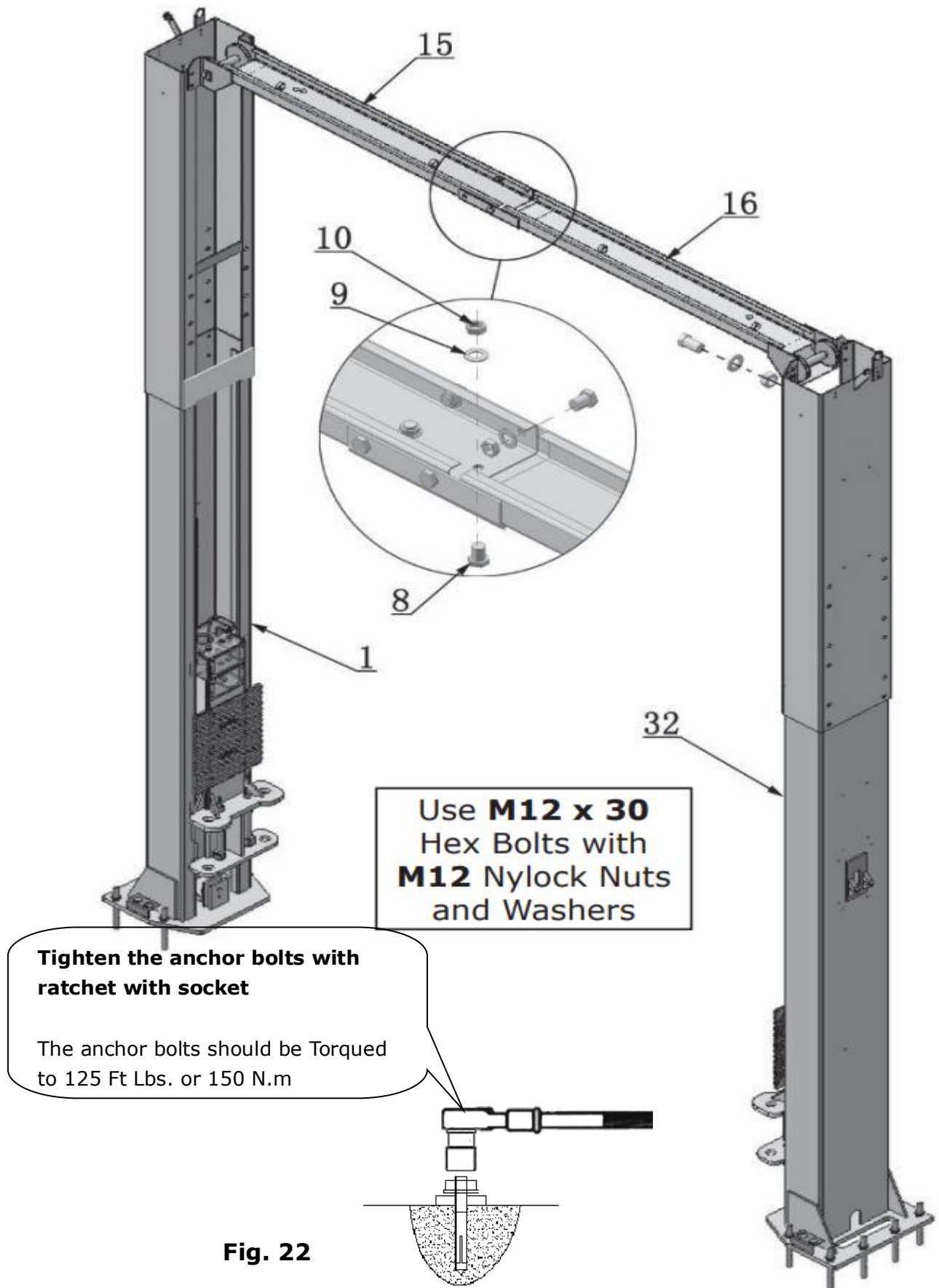

Fig. 22

I. Installing the limit switch control bar and limit switch (See Fig. 23)

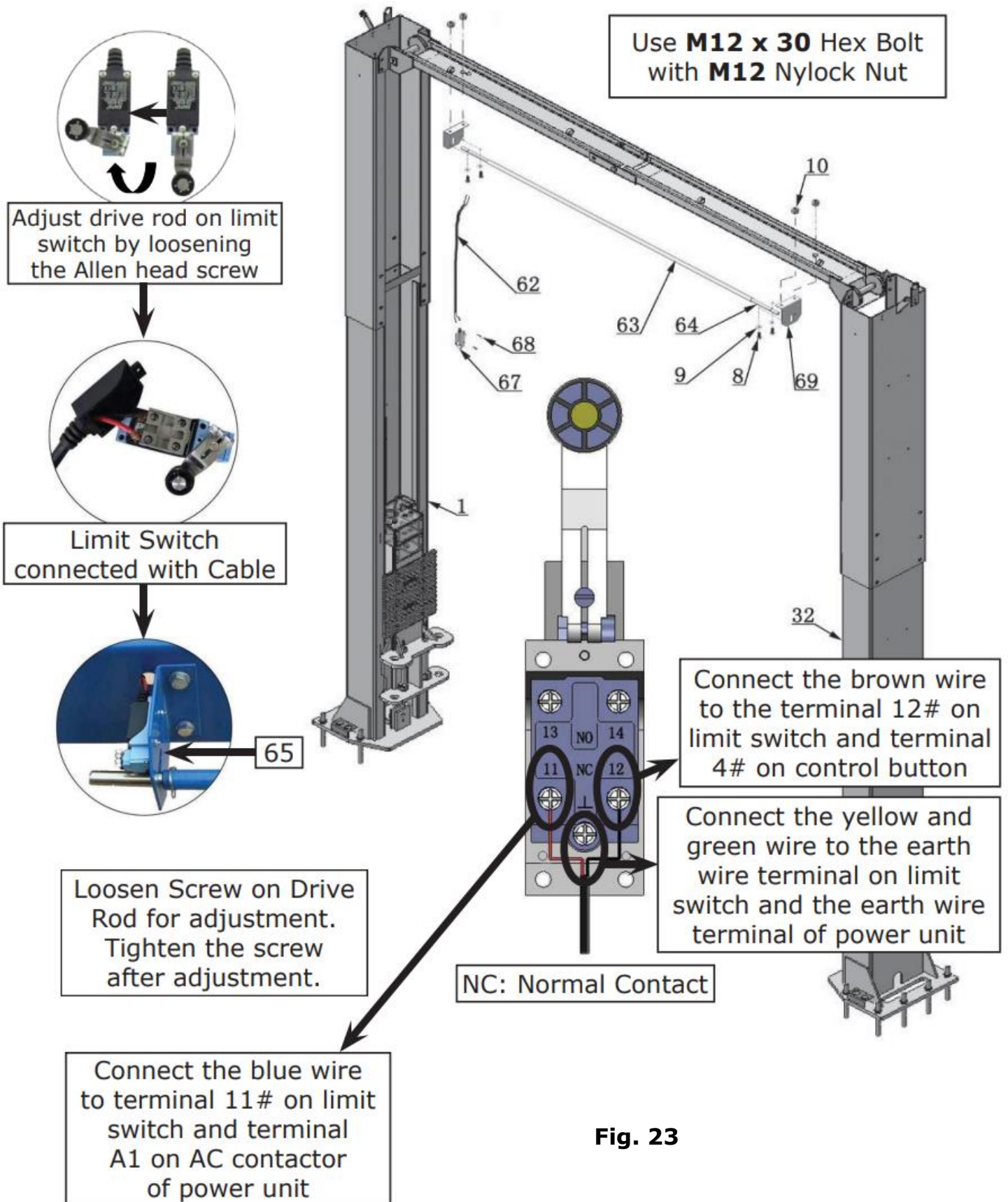

Fig. 23

J. Install safety device (See Fig. 24 & Fig. 25).

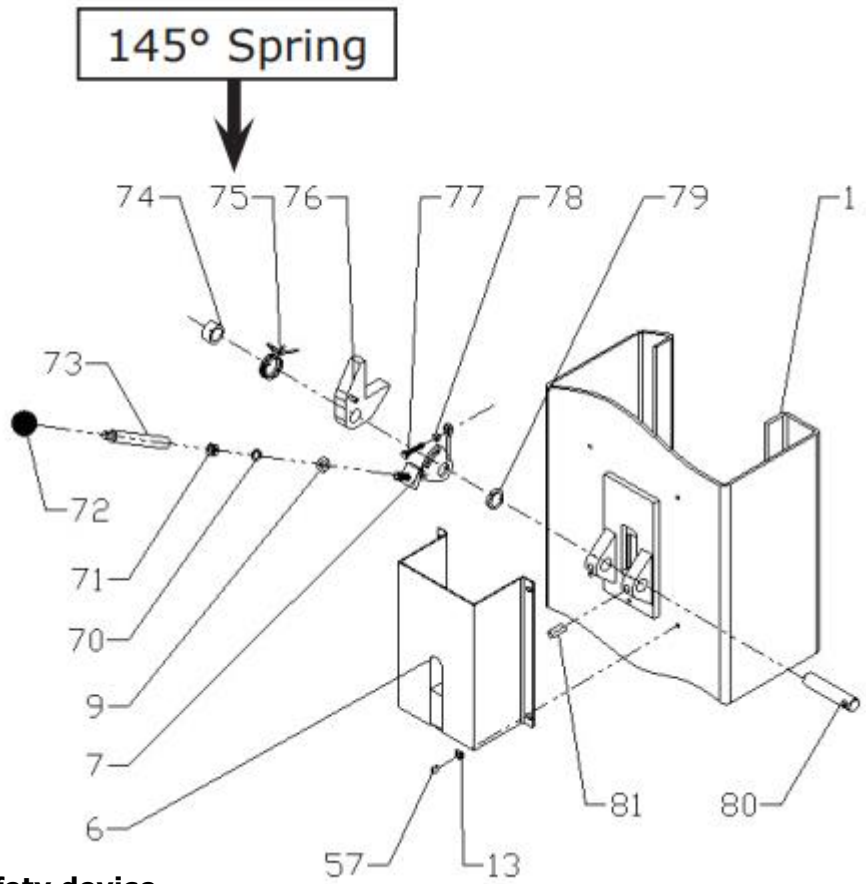
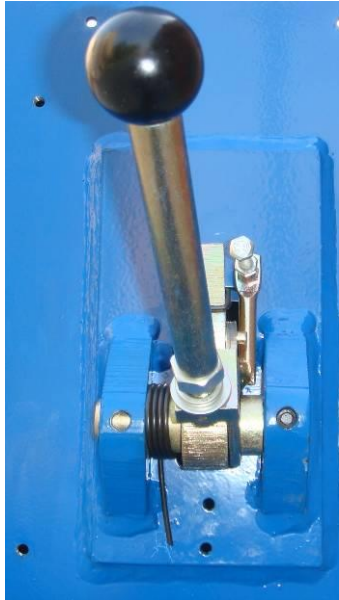

Fig. 24 Power side safety device

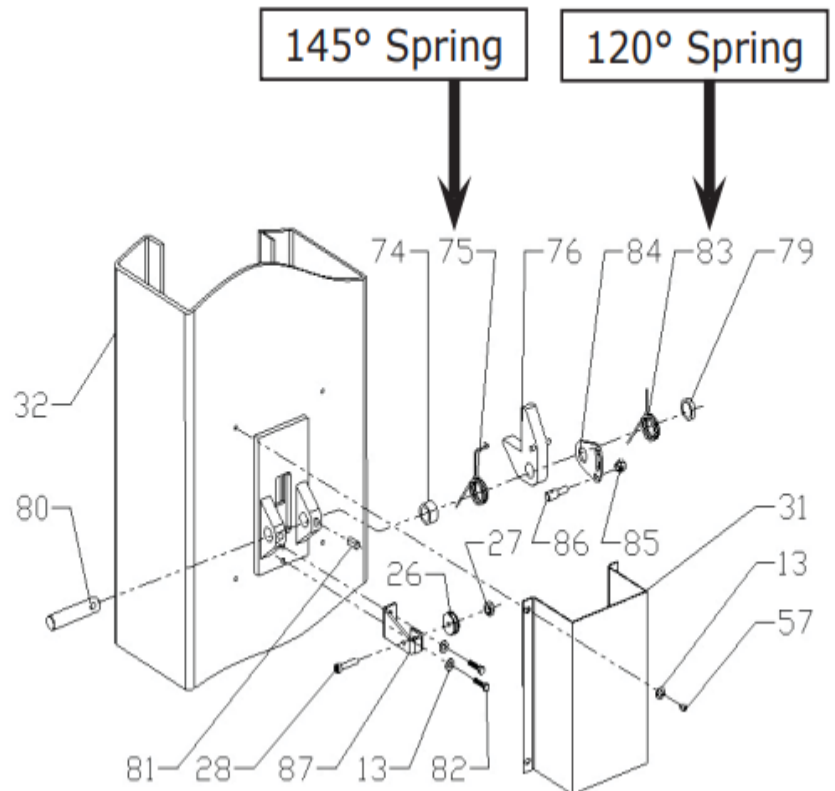

Fig. 25 Offside safety device

K. Lift the carriages up manually and set on the 1st set of locks. (See Fig. 26).

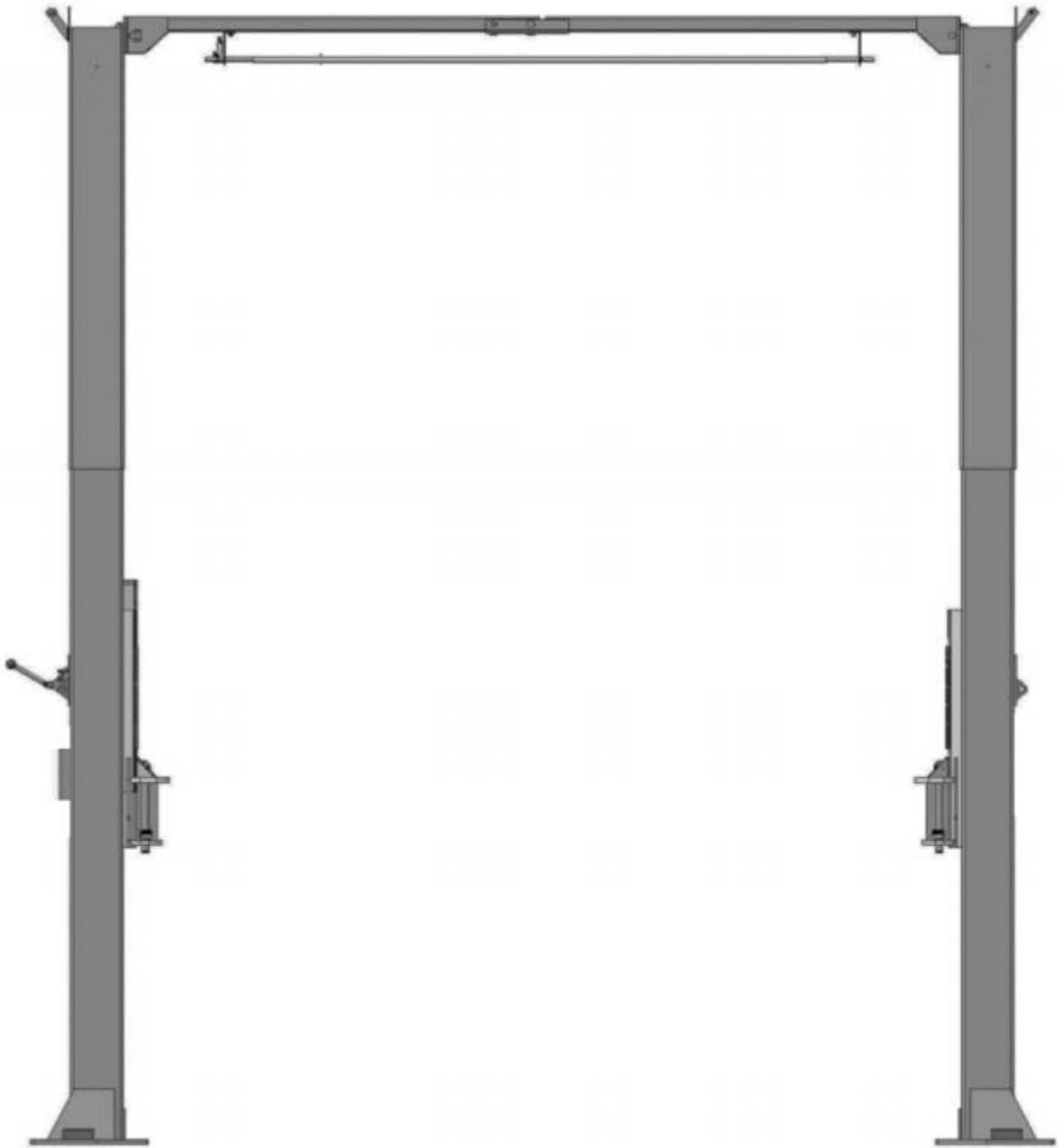

Fig. 26

L. Install cables

1. High setting cable connection: suitable for ceiling height over 177 1/8".

1.1 Remove carriages' plastic cover, pass cable through from the bottom of the carriages and be pull through the openings of the carriages, then screw on/adjust the two cable nuts (See Fig. 27).

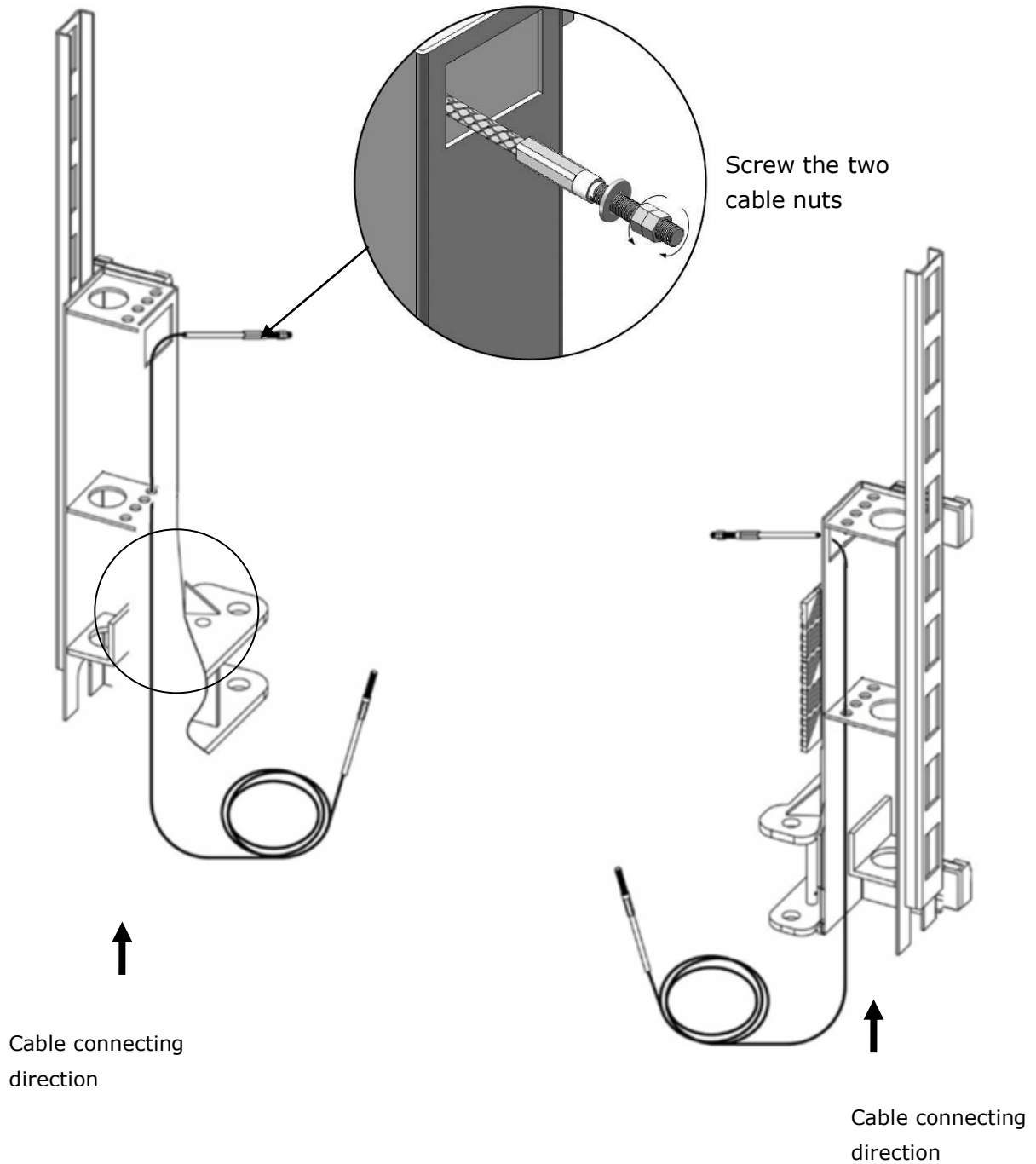

Fig. 27

1.2 Connecting cable for high setting (See Fig. 28)

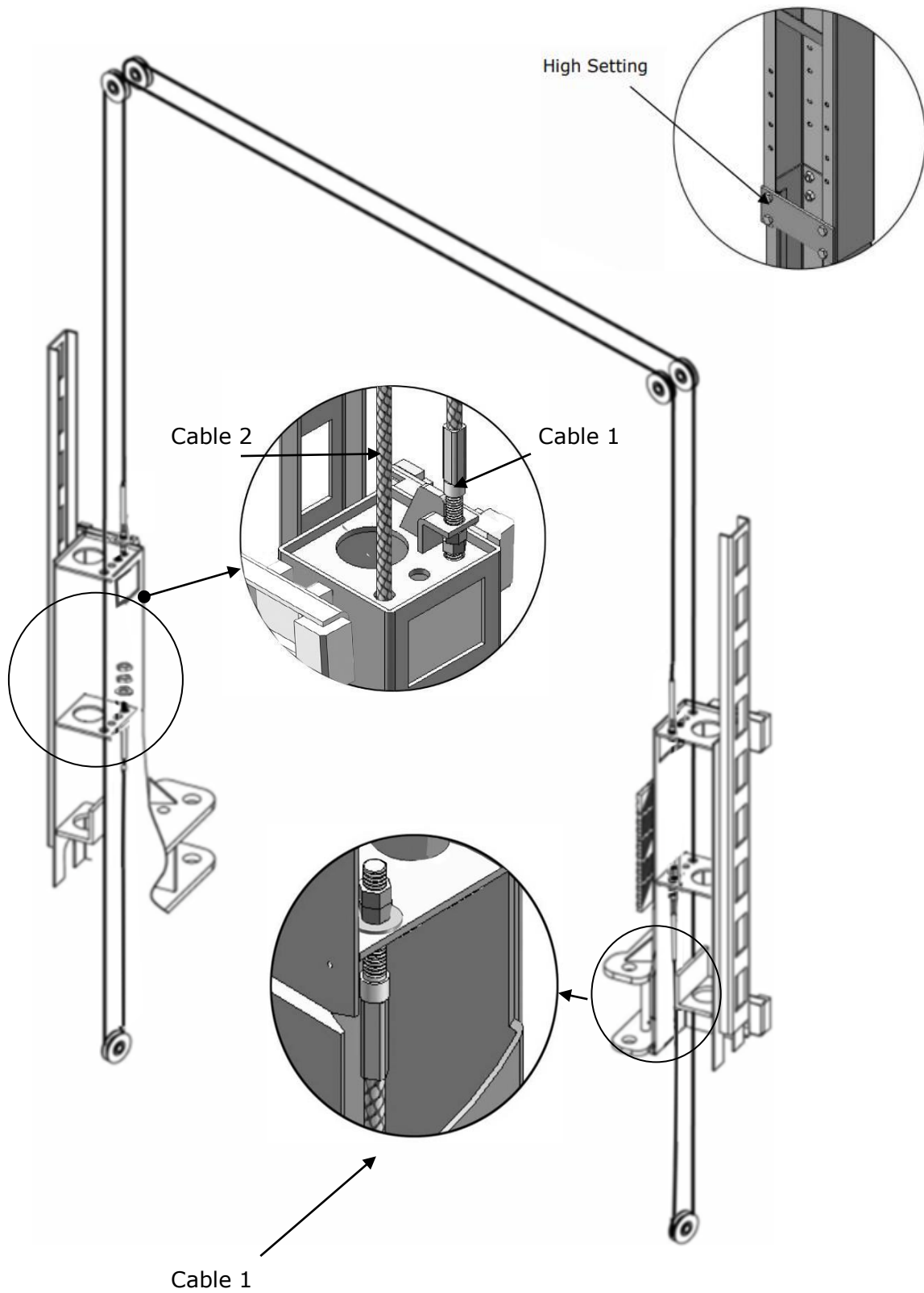

Fig. 28

2. Low setting cable connection; suitable for ceiling heights between 165 3/8" to 177 1/8". (See Fig. 29)

Note: Cable should go inside of the carriage.

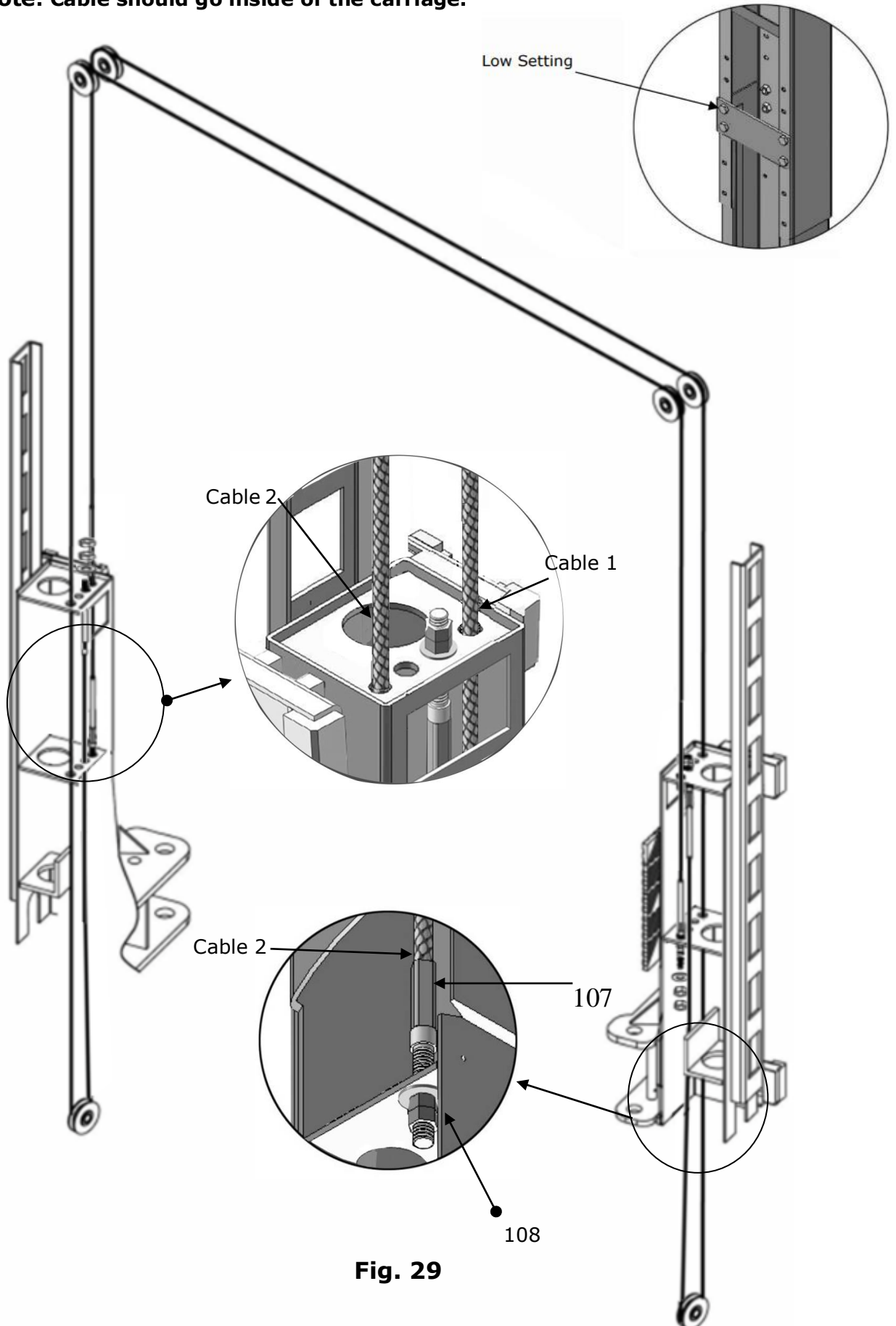

Fig. 29

3. Special low setting cable connection; suitable for ceiling height less than 165 3/8". NOTE: This setting requires purchase of additional cables. (See Fig. 30)

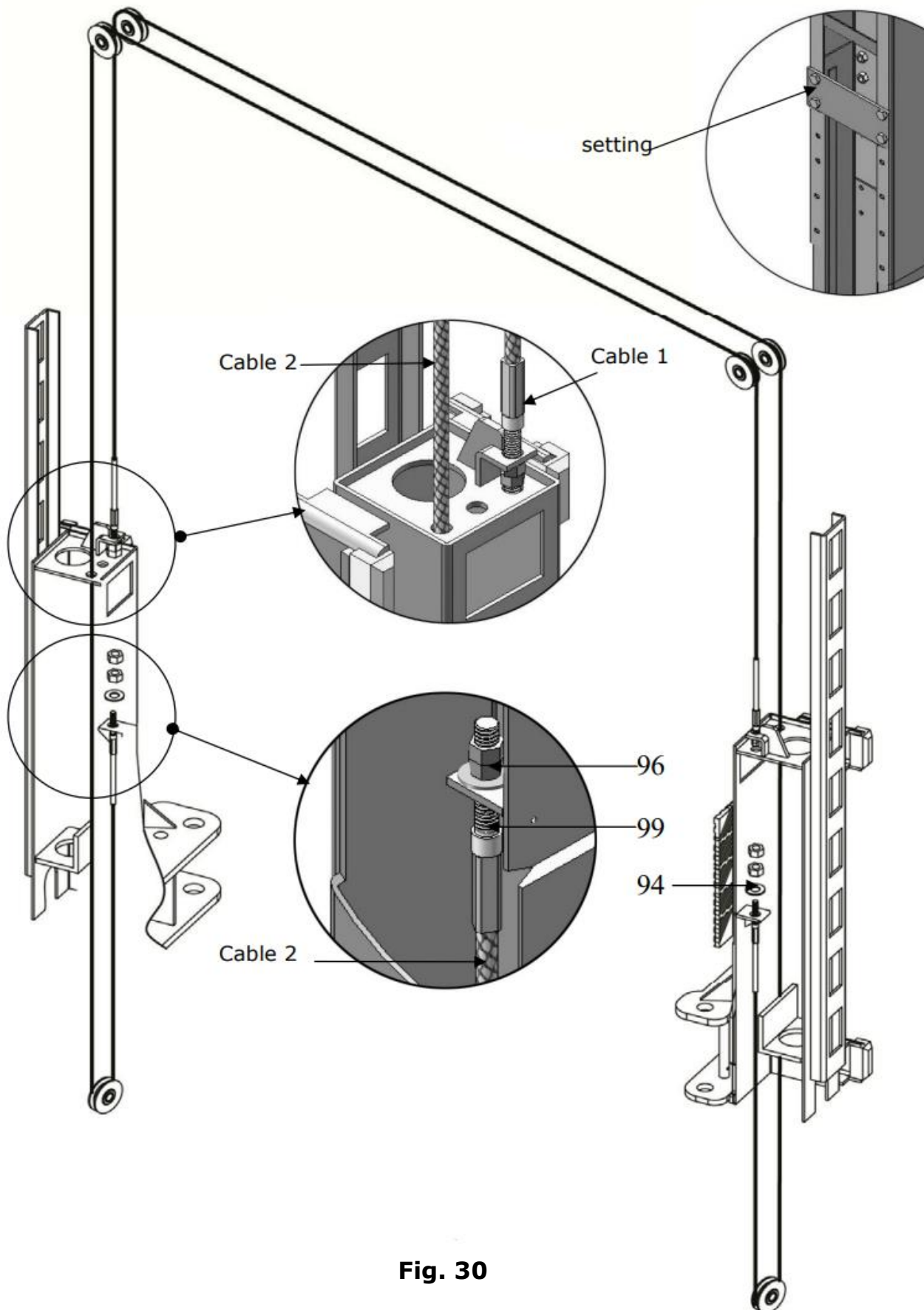

Fig. 30

M. Install power unit (See Fig. 31)

Use **M8 x 25** Hex Bolts
with **M8** Nuts & Washers

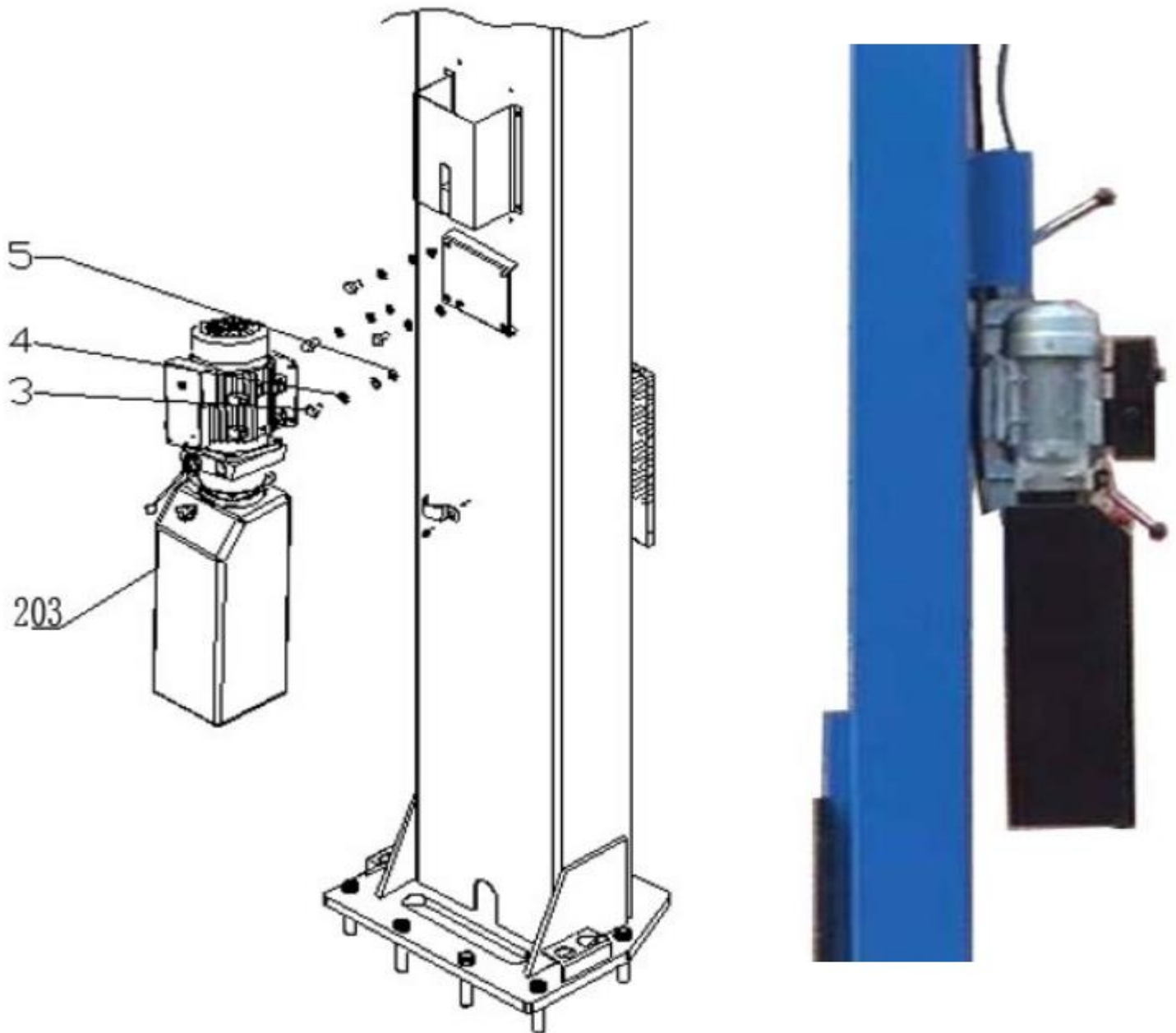

Fig. 31

N. Install oil hose

At high setting and low setting oil hose connection (See Fig. 32).

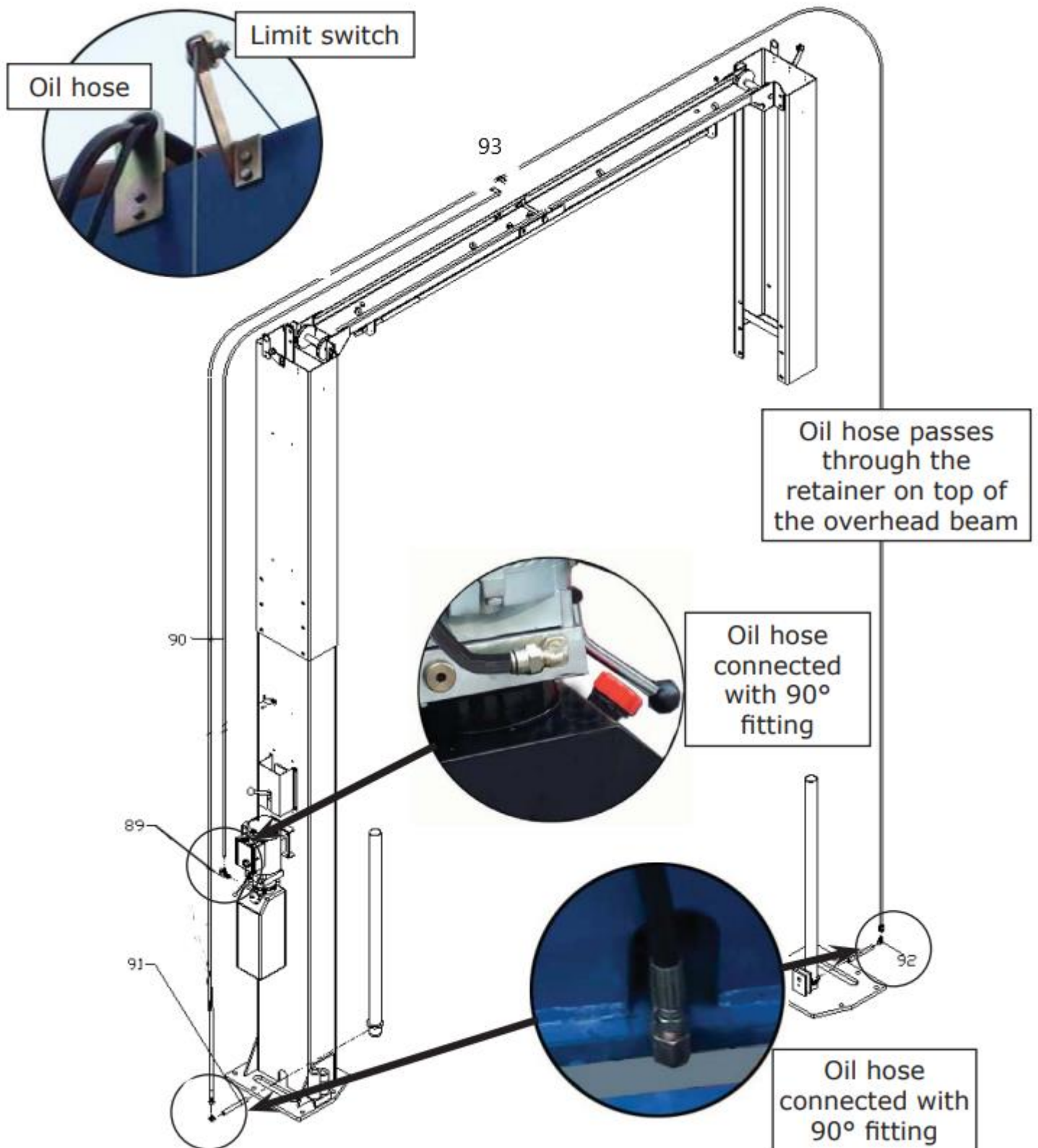
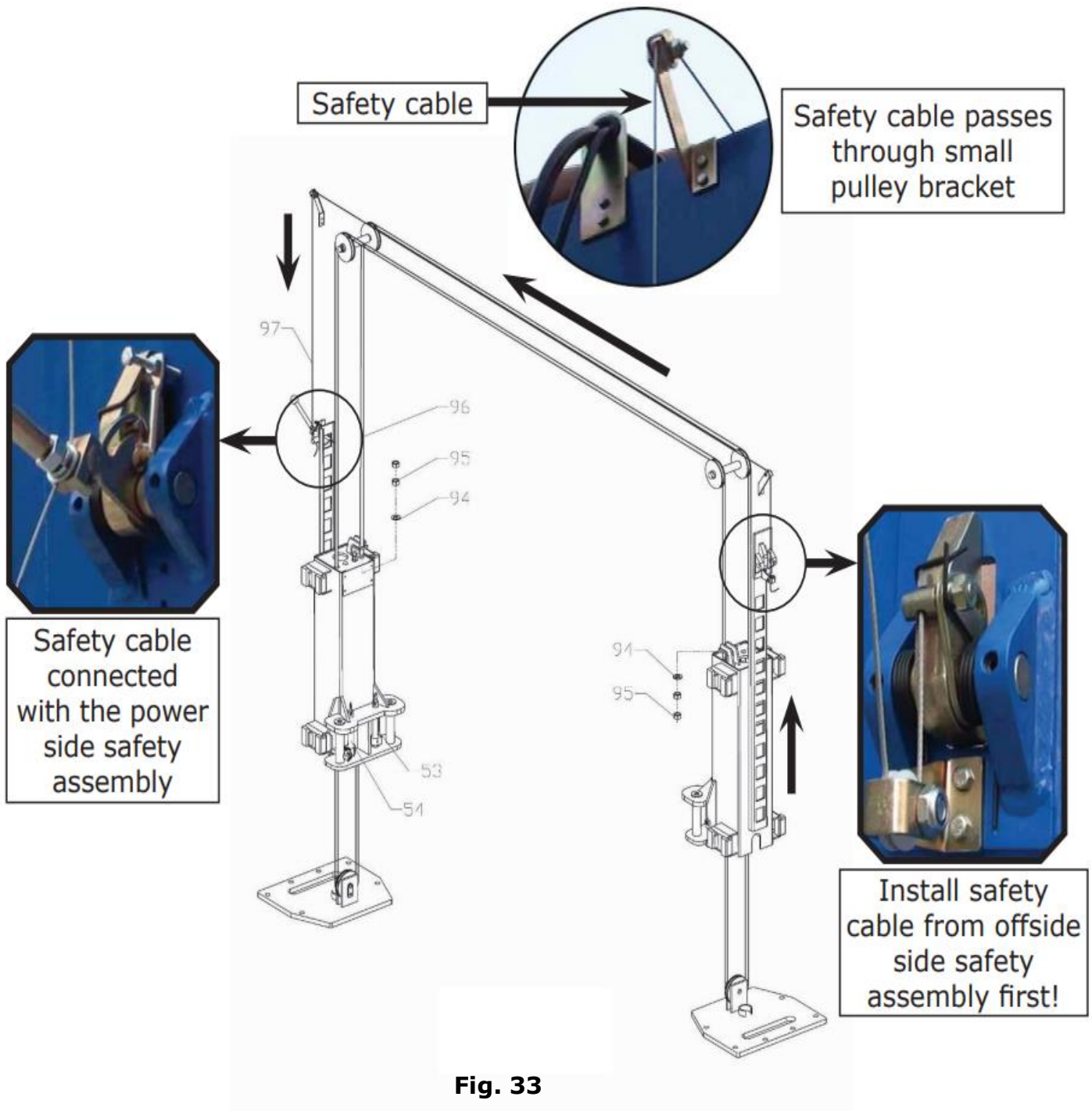

Fig. 32

O. Install safety cable.

Install safety cable from offside safety device to power-side safety device, pass through the top beam (See Fig. 33)



P. Install hose retainers on both columns (See Fig. 34).

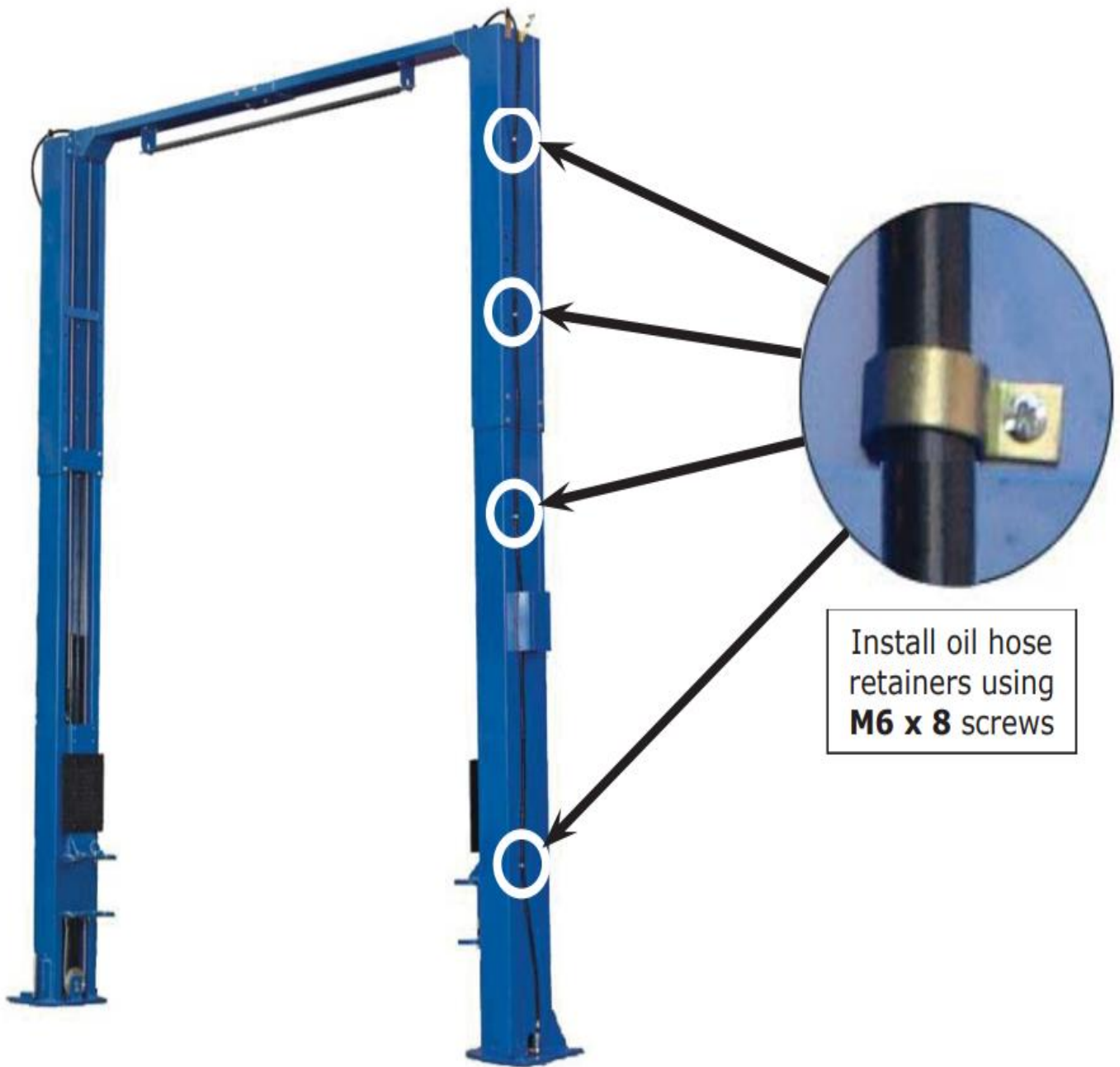
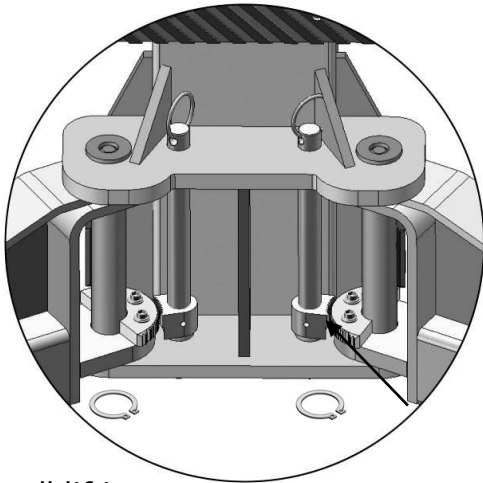

Fig. 34

Q. Install lifting arms and adjust the arm locks

1. Install lifting arms (**See Fig. 35**).
2. Lower the carriages down to the lowest position, then use an 8mm allen wrench to loosen the socket bolt (**See Fig. 36**).
3. Adjust moon gear as direction of arrow (**See Fig. 37**).
4. Adjust moon gear and arm lock to make it to be meshed, then tighten the socket bolts of arm lock (**See Fig. 38**).



Install lifting arms

Snap Ring

Fig. 35

Loosen the Socket Bolt

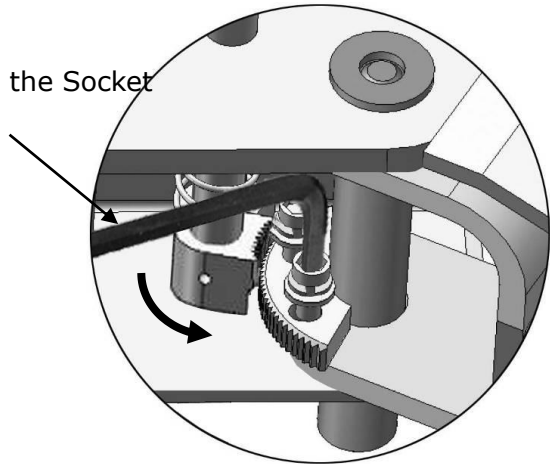

Fig. 36

use the 8# socket head wrench to loosen the socket bolt

Adjusting Moon gear

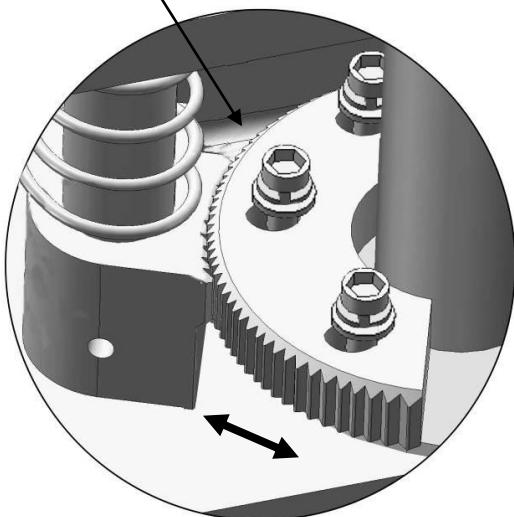

Fig. 37

Tighten the bolt

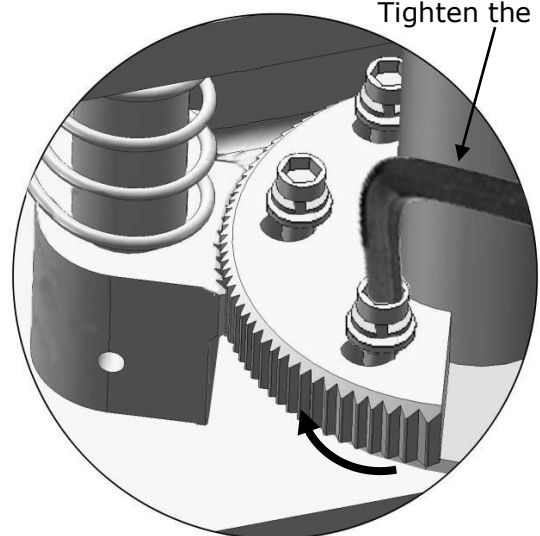

Fig. 38

Locking the bolts after the moon gear and arm lock engaged well

R. Tighten All Hydraulic Fittings and Fill the reservoir with Hydraulic Oil.

Approximately 4 gallons are required.

Note: For the best performance it is recommended to use AW32 or AW46 series hydraulic oil.

S. Install electrical system

Connect the power source according to the data plate on the Power Unit.

Remove the short "Pig Tail" wire connected to the AC contactor terminals.

This wire was used to test the motor after production.

ATLAS Single phase motor

Please Note: This motor is powered by Alternating Current and the terminals on the AC contactor are not wire color specific. There are no positive or negative terminals.

Single phase motor (See Fig. 39).

Remove Existing Pigtail From Lift (Do Not Operate Until Completed)

1.) Incoming Power (Factory Installed)

- a.) One hot to **terminal 6**
- b.) One hot to **terminal 2**
- c.) Ground to ground

2.) Motor (Factory Installed)

- a.) One hot to **terminal 8**
- b.) One hot to **terminal 4**

3.) Limit Switch

- a.) Cut ground off,
DON'T USE!
- b.) One hot to **Up Button terminal 4**
- c.) One hot to **terminal 1**

4.) Jumpers (Factory Installed)

- a.) Jumper from **Up Button terminal 3** to **terminal 6**
- b.) Jumper from **terminal 2** to **terminal 0**

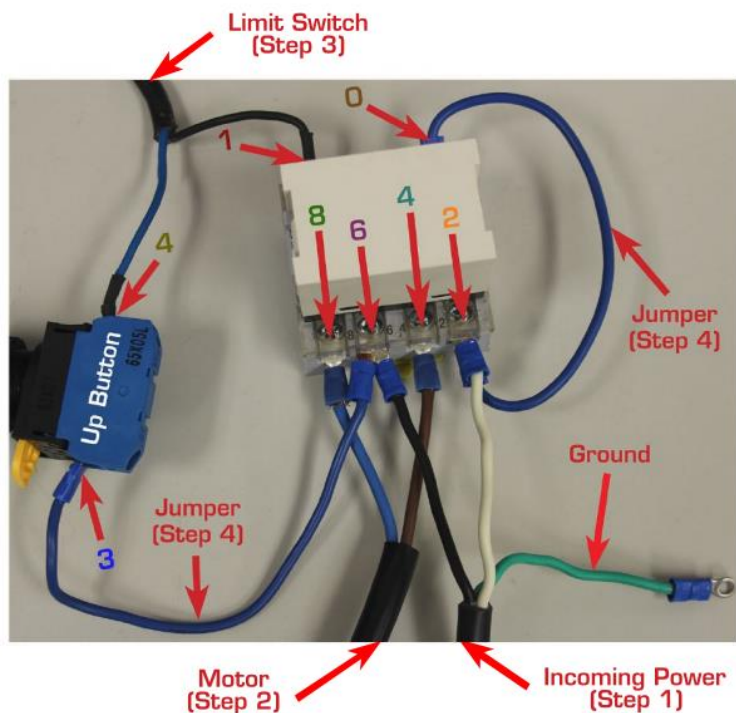
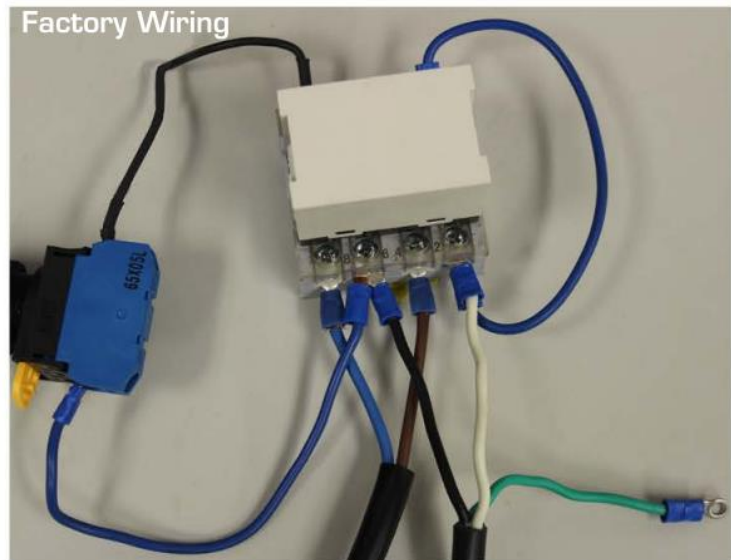

Fig. 39

IV. EXPLODED VIEW

Model PV15

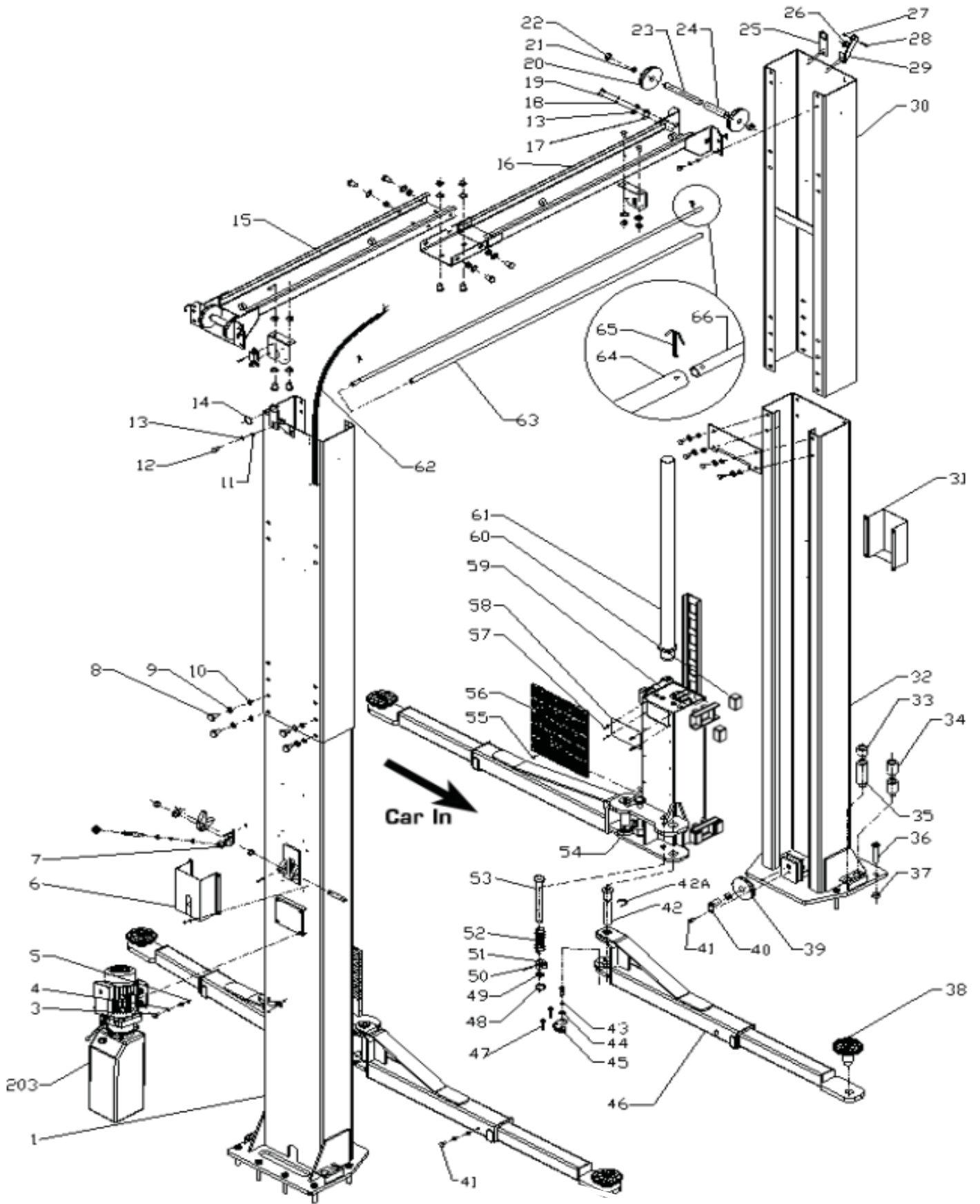

Fig. 40

PV15 PARTS LIST

Item	Part #	Description	Qty
1	217174A	Power side Column	1
2/203	PU220VETL-15	Power unit	1
3	209003	Bolt	4
4	209033	Lock Washer	4
5	209005	Nut	4
6	QL4L-520-00	Power side Lock Cover	1
7	QL4L-210-00	Main Cam Lock	1
8	217069	Bolt	34
9	206006	Washer	35
10	206023	Self-Locking Nut	34
11	420018	Self-Locking Nut	8
12	217013	Bolt	8
13	420045	Washer	26
14	217025	Protective Ring	2
15	217015B	Right Overhead Bar	1
16	217016B	Left Overhead Bar	1
17	420044	Pin Stop	2
18	209149	Washer	8
19	420138	Bolt	4
20	QL4L-400-02	Top Pulley	4
21	217020	Bronze Bush for Pulley	6
22	217021	Top Pulley Spacer	4
23	217022	Pin	2
24	217033	Pin Spacer	2
25	217024	Hose Support	2
26	QL4L-000-10	Plastic Small Pulley	3
27	209056	Self-Locking Nut	3
28	209046	Bolt	3
29	217026	Safety Cable Bracket	2
30	217192B	Extension Column	2
31	QL4L-410-00	Offside Lock Cover	1
32	217175A	Offside Column	1
33	QL40-000-04	Adapter 1.25"	4
34	209052B	Adapter 2.5"	4
35	QL40-000-05	Adapter 5"	4
36	WA347	Anchor Bolt	12
37	620065	Shim	10
38	217114A	Rubber Pad Assembly	4
39	217036	Bottom Pulley	2
40	217037	Bottom Pin	2
41	209038	Bolt	6

Item	Part #	Description	Qty
42	217047B	Arm Pin	4
43	209039	Lock Washer	18
44	209022	Washer	18
45	206049	Moon Gear	4
46	217052D	Lift Arm	4
47	206048	Allen Bolt	12
48	206032	C-Clip	4
49	217043	Limit Ring	4
50	206036	Roll Pin	4
51	217044	Arm Lock	4
52	217045	Spring	4
53	217046A	Left Arm Lock Bar	2
54	217046	Right Arm Lock Bar	2
55	209019	Flat Head Screw	12
56	217053	Protective Rubber	2
57	209009	Cup Head Bolt	26
58	217054	Carriage Plastic Cover	2
59	PV15-CARRIAGE	Carriage	2
60	217188	Slider Block	16
61	PV15-9100	Cylinder	2
62	217173	Wire Cable	1
63	206025A	Foam Cushion	1
64	206129	Limit Bar	1
65	201005	Split Pin	2
66	206025C	Limit Bar Link	2
67	LX19-001	Limit Switch	1
68	206011	Cup head Bolt	2
69	206042	Limit Bar Bracket	2
70	420026	Lock Washer	1
71	206023A	Nut	1
72	217005	Plastic Ball	1
73	217006	Lock Handle	1
74	217007	Large Spacer	2
75	QL4L-200-02	Main Spring	2
76	QL4L-230-00	Main Lock	2
77	217010	Bolt	1
78	217011	Nut	1
79	217012	Small Spacer	2
80	217050	Main Lock Pin	2
81	217051	Screw	2
82	217066	Bolt	2

Item	Part #	Description	Qty
83	QL4L-200-04	Torsion Spring	1
84	217031	Cam Lock	1
85	217033	Self-Locking Nut	1
86	217032	Cable Lock Hold	1
87	217029	Small Pulley Bracket	1
88	PV12-4003	Oil Hose	2
89	305720	90 Fitting for Power Unit	1
90	PV12-4004	Oil Hose	1
91	PV10-4021	Extended fitting for Cylinder	2
92	217191	Hose Clamp	10
93	SW-001	Hydraulic T-Fitting	1
94	420029	Cable Nut Washer	4
95	209066	Cable Nut	8
96	PV12-4500	Equalizing Cable	2
97	217064B	Lock Release Cable	1
99	PV15-N-PBX	Parts Box	1

V. TEST RUN

1. Adjust the equalizing cable (See Fig. 41)

Use wrench to hold the cable end, meanwhile use ratchet to tighten the cable nuts until both cables have the same tension. **If the two carriages do not lift at the same time, screw and tighten the cable nuts on the lower of the two carriages.**

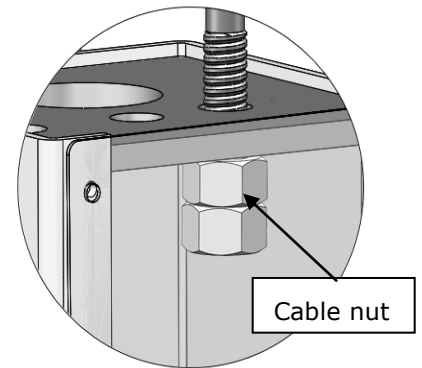

Fig. 41

2. Adjust safety cable

Lift the carriages and lock at the same height, pull the safety cable and then release a little, and then tighten the safety cable nuts. Make sure the safety locks click at the same time.

3. Bleeding air from oil cylinder (See Fig. 42)

This hydraulic system is designed to bleed air by loosening the bleeding screw on top of the cylinders. Lift the carriages to about 12 inches and loosen the bleeding plug. Lower the lift until fluid comes out. Tighten the screws after bleeding.

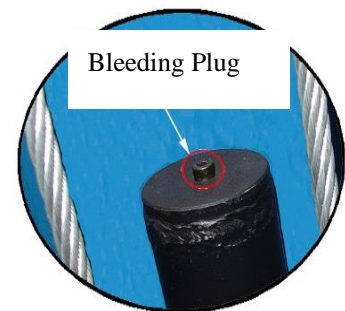
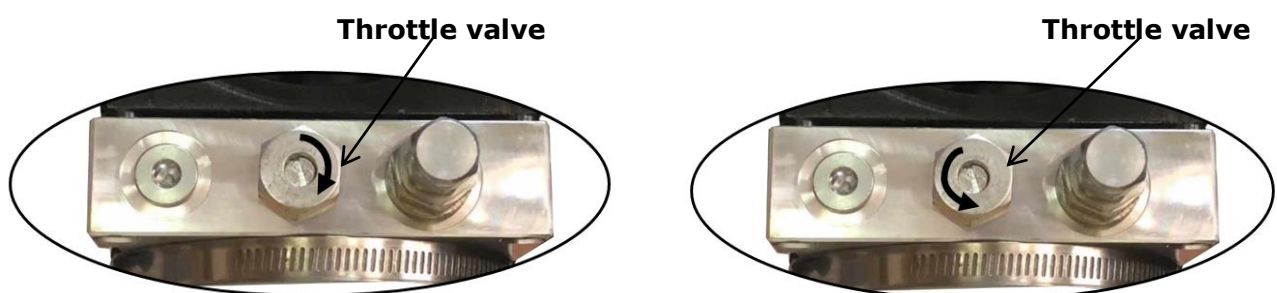

Fig. 42

4. Adjust the lowering speed (Only for ATLAS power unit) (Adjust with a load on the lift) (See Fig. 43)

You can adjust the lowering speed of the lift if needed: Loosen the locking nut on the throttle valve, and then turn the throttle valve clockwise to decrease the lowering speed, or counterclockwise to increase the lowering speed.



Adjust clockwise, decrease lowering speed

Counterclockwise, increase lowering speed

Fig. 43

5. Test with load

After finishing the above adjustment, test running the lift with load. Run the lift in low position several times first. Run the lift to the top completely.

NOTE: If the lift vibrates on the way up with a load, lubricate all pulley shafts and wear blocks. If the lift vibrates on the way down, the cylinders need to be bled.

Hydraulic Schematic Diagram

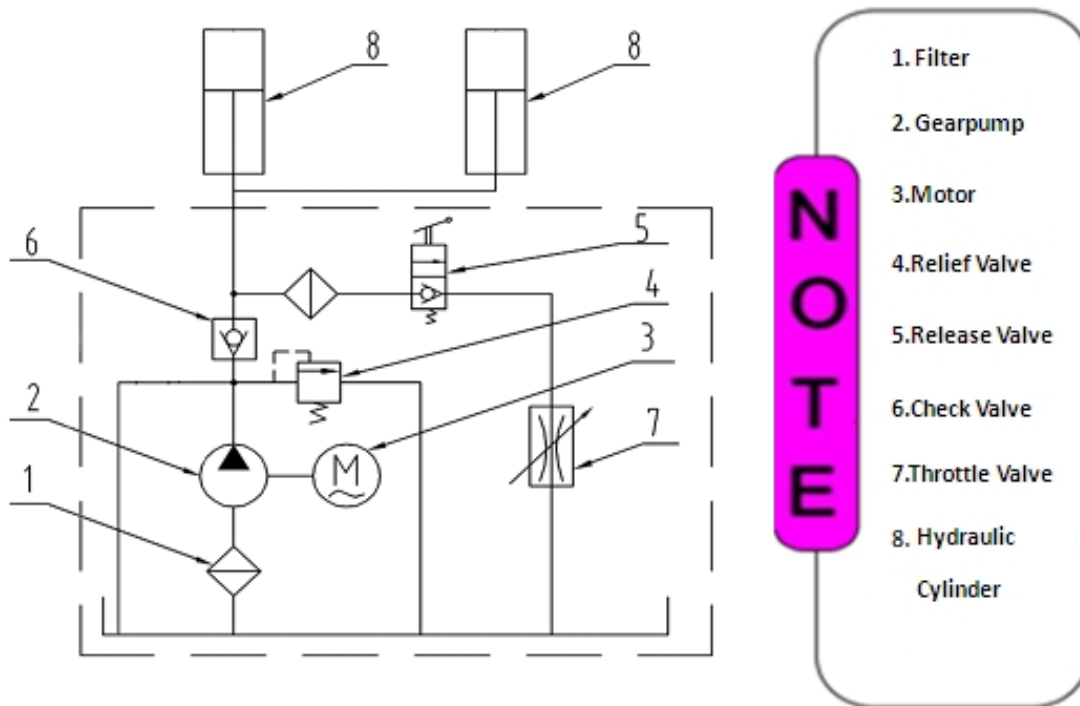

Fig. 44

VI. OPERATION INSTRUCTIONS

Please read the safety tips carefully before operating the lift

To lift vehicle

1. Keep the lift area clean and free of clutter;
2. Position lift arms to the lowest position, on floor;
3. Open or swing lift arms away from center of lift;
4. Position vehicle between columns;
5. Move or swing arms to the vehicle's lifting points;

NOTE: The four lift arms must make contact at the same time with the vehicle's lifting and both axles must rise off the ground at the same time

6. Push "**UP**" button until the lift pads contact underside of vehicle. Raise vehicle just enough that the wheels are off the floor. Recheck to make sure vehicle is secure.
7. Continue to raise the lift slowly to the desired working height.
8. Push lowering handle to lower lift onto the nearest safety lock. The vehicle is ready to repair.

NOTE: The lift must always be on the safety locks when holding a vehicle.

To lower vehicle

1. Keep the lift area clean and free of clutter.
2. Push "**UP**" button to raise the vehicle slightly, and then pull the safety lock handle to release the safety locks, lower vehicle by depressing the power unit lowering handle.
3. Lower the vehicle completely to the floor, until arms no longer contact the vehicle.
4. Open the arms and position them to the shortest length.
5. Drive the vehicle out of the lift.

VII. MAINTENANCE SCHEDULE

Monthly:

1. Re-torque the anchor bolts to 85 Ft Lbs;

Note: All anchor bolts should take full torque. If any of the bolts do not for any reason, DO NOT use the lift until the bolt has been replaced.

2. Check all connectors, bolts and pins to ensure proper mounting;
3. Lubricate cable with lubricant;
4. Make a visual inspection of all hydraulic hoses/lines for possible wear or leakage;
5. Check Safety locks and make sure they are in proper condition;
6. Lubricate all Rollers and Pins with 90wt. Gear oil or equivalent;

Every six months:

1. Make a visual inspection of all moving parts for possible wear, interference or damage.
2. Check and adjust as necessary the tension of the equalizer cables to ensure level lifting.
3. Check columns for plumbness.
4. Check Rubber Pads and replace as necessary.
5. Check Safety locks and make sure proper condition.

Oil cylinder maintenance:

In order to extend the service life of the oil cylinder, please operate according to the following requirements.

1. Recommend the use of AW32 or AW46 anti-wear hydraulic oil.
2. The hydraulic oil of the lifts should be replaced regularly during use. Replace the hydraulic oil 3 months after the first installation, Replace the hydraulic oil once a year afterwards.
3. Make at least one full trip raising and lowering per day. To bleed any air from the system, which could effectively avoid the corrosion of the cylinder and damage to the seals caused by presence of air or water in the system.

Protect the outer surface of the oil cylinder's piston rod from bumping and scratching, and clean any debris on the oil cylinder dust-ring and the piston rod as soon as possible.

VIII. TROUBLE SHOOTING

TROUBLE	CAUSE	REMEDY
Motor does not run	<ol style="list-style-type: none"> 1. Start button does not work 2. Wiring connections are not in good condition 3. Motor burned out 4. AC contactor in damage 	<ol style="list-style-type: none"> 1. Replace Start button 2. Repair all wiring connections 3. Repair or replace motor 4. Replace or replace
Motor runs but the lift is not raised	<ol style="list-style-type: none"> 1. Motor runs in reverse rotation 2. Gear pump out of operation 3. Release valve in damage 4. Relief valve or check valve in damage 5. Low oil level 	<ol style="list-style-type: none"> 1. Reverse two power wire 2. Repair or replace 3. Repair or replace 4. Repair or replace 5. Fill tank
Lift does not stay up	<ol style="list-style-type: none"> 1. Release valve out of work 2. Relief valve or check Valve leakage 3. Cylinder or fittings leaks 	Repair or replace
Lift raises slowly	<ol style="list-style-type: none"> 1. Oil line is jammed 2. Motor running on low voltage 3. Oil mixed with air 4. Gear Pump leaks 5. Overload lifting 	<ol style="list-style-type: none"> 1. Clean the oil line 2. Check electrical system 3. Fill tank 4. Replace pump 5. Check load
Lift cannot lower	<ol style="list-style-type: none"> 1. Safety device are locking. 2. Release valve in damage 3. Safety cable broken 4. Oil system is jammed 	<ol style="list-style-type: none"> 1. Release the safeties 2. Repair or replace 3. Replace 4. Clean the oil system

IX. LIFT DISPOSAL:

When the car lift cannot meet the requirements for normal use and needs to be disposed, it should follow local laws and regulations.

X. WARRANTY:



This item is warranted for five (5) years on structural components, two (2) years on hydraulic cylinders, and one (1) year on electric or air / hydraulic power units from invoice date. Wear items are covered by a 90 day warranty.

This LIMITED warranty policy does **not include a labor** warranty.

NOTE: ALL WARRANTY CLAIMS MUST BE PRE-APPROVED BY THE MANUFACTURER TO BE VALID.

The Manufacturer shall repair or replace at their option for this period those parts returned to the factory freight prepaid, which prove after inspection to be defective. This warranty will not apply unless the product is installed, used and maintained in accordance with the Manufacturers installation, operation and maintenance instructions.

This warranty applies to the ORIGINAL purchaser only, and is non-transferable. The warranty covers the products to be free of defects in material and workmanship but, does not cover normal maintenance or adjustments, damage or malfunction caused by: improper handling, installation, abuse, misuse, negligence, carelessness of operation or normal wear and tear. In addition, this warranty does not cover equipment when repairs or alterations have been made or attempted to the Manufacturer's products.

THIS WARRANTY IS EXCLUSIVE AND IS LIEU OF ALL OTHER WARRANTIES EXPRESSED OR IMPLIED INCLUDING ANY IMPLIED WARRANTY OR MERCHANTABILITY OR ANY IMPLIED WARRANTY OF FITNESS FROM A PARTICULAR PURPOSE, AND ALL SUCH IMPLIED WARRANTIES ARE EXPRESSLY EXCLUDED.

THE REMEDIES DESCRIBED ARE EXCLUSIVE AND IN NO EVENT SHALL THE MANUFACTURER, NOR ANY SALES AGENT OR OTHER COMPANY AFFILIATED WITH IT OR THEM, BE LIABLE FOR SPECIAL CONSEQUENTIAL OR INCIDENTAL DAMAGES FOR THE BREACH OF OR DELAY IN PERFORMANCE OF THIS WARRANTY. THIS INCLUDES, BUT IS NOT LIMITED TO, LOSS OF PROFIT, RENTAL OR SUBSTITUTE EQUIPMENT OR OTHER COMMERCIAL LOSS.

PRICES: Prices and specifications are subject to change without notice. All orders will be invoiced at prices prevailing at time of shipment. Prices do not include any local, state or federal taxes.

RETURNS: Products may not be returned without prior written approval from the Manufacturer. DUE TO THE COMPETITIVENESS OF THE SELLING PRICE OF THESE LIFTS, THIS WARRANTY POLICY WILL BE STRICTLY ADMINISTERED AND ADHERED TO.

Revise Date: 09/29/23