

Atlas APEX RJ7

7,000 lb. Capacity
Air/Hydraulic Rolling Jack



Atlas Automotive Equipment
www.atlasautoequipment.com
(866) 898-2604

Read this entire manual before operation begins.

Record below the following information which is located on the serial number data plate.

Serial No. _____

Model No. _____

Date of Installation _____

Contents

General Information	4
Description	6
Installation	8
Operation And Use	11
Maintenance	13
Troubleshooting	15
Part List	16

General Information

This manual has been written to be used by shop technicians in charge.

The operating instructions are considered to be an integral part of the product and must remain with it for its whole useful life.

Read every section of this manual carefully before operation.

The company is not liable for possible problems, damage, accidents, etc. resulting from failure to follow the instructions contained in this manual.

Only skilled technicians of AUTHORIZED DEALERS or SERVICE CENTERS AUTHORIZED by the manufacturer shall be allowed to carry out lifting, transport, assembling, installation, adjustment, calibration, settings, extraordinary maintenance, repairs, overhauling and dismantling of the product.

The manufacturer is not responsible for possible damage to people, vehicles or objects if said operations are carried out by unauthorized personnel or the product is improperly used.

Any use of the product made by operators who are not familiar with the instructions and procedures contained herein shall be forbidden.

For a proper use of this manual, the following is recommended:

- keep the manual near the lift, in an easily accessible place.
- keep the manual in an area protected from the damp.
- use this manual properly without damaging it.
- any use of the machine made by operators who are not familiar with the instructions and procedures contained herein shall be forbidden.

This manual is an integral part of the product: it shall be given to the new owner if and when it is resold.

Operators must not be under the influence of sedatives, drugs or alcohol when operating the product.

Declaration Of Warranty And Limitation Of Liability

The manufacturer has paid proper attention to the preparation of this manual. However, nothing contained herein modifies or alters, in any way, the terms and conditions of manufacturer agreement by which this lift was acquired, nor increase, in any way, manufacturer's liability to the customer.

To The Reader

Every effort has been made to ensure that the information contained in this manual is correct, complete and up-to date. The manufacturer is not liable for any mistakes made when drawing up this manual and reserves the right to make any changes due the development of the product, at any time.

Description

2.1 Description

- This hydraulic jacking beam is intended to be placed on a proper 4 post lift for raising a vehicle wheel-free.
- In particular **THE MANUFACTURER** cannot be held responsible for any damage caused by other use purposes, and therefore inappropriate, incorrect and unreasonable.

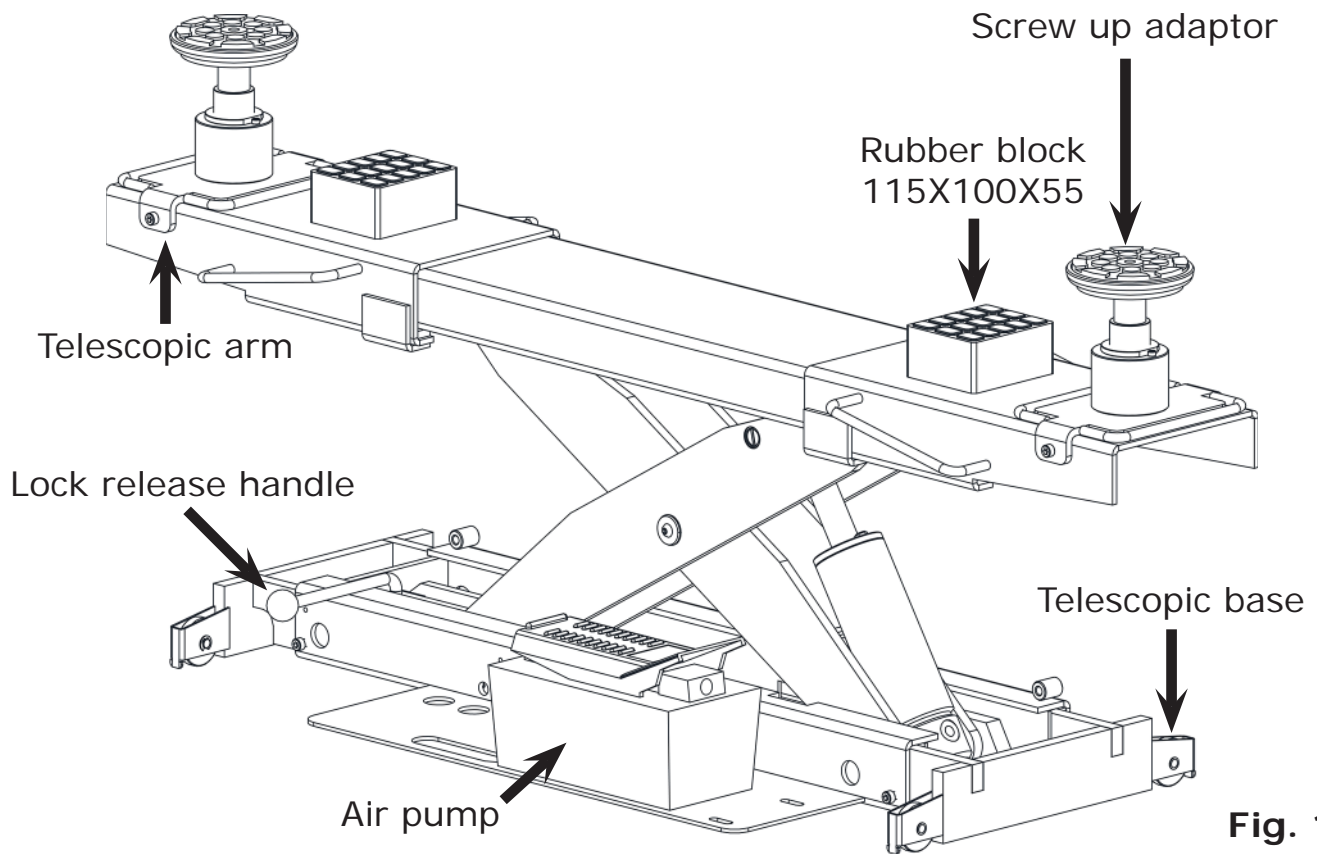

Fig. 1

2.2 Specifications

Capacity	3200 Kg (7000 lbs)
Compressed Air Pressure	6 bar – 8 bar
Max. Working Hydraulic Pressure	300 bar
Working Temperature	0 °C - 40 °C
Average Weight Of The Package	160kg

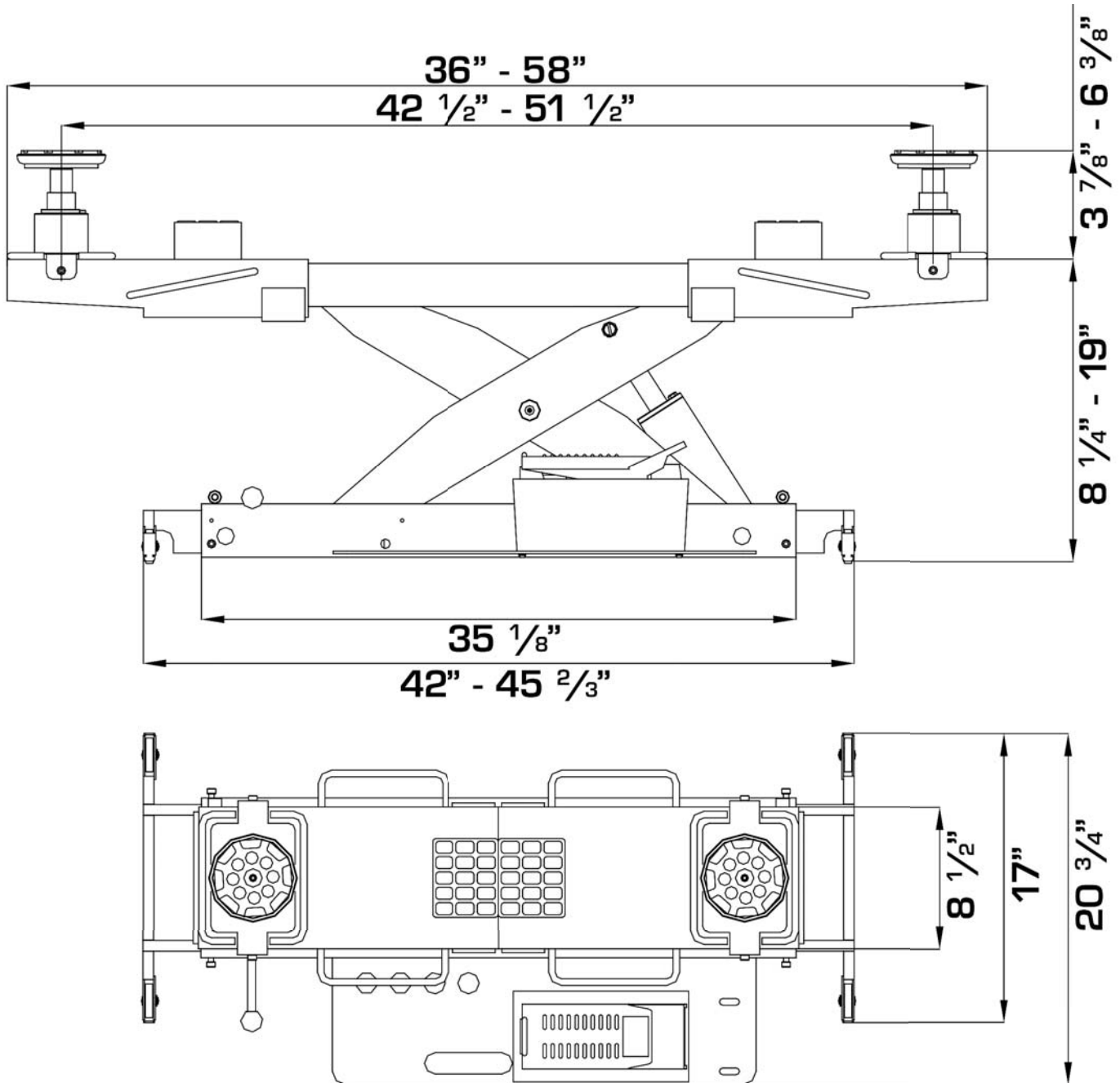

Fig. 2

Installation

3.1 Installation Onto Lift

- Lower the lift fully.
- Lower the jacking beam all the way down.
- Use a proper hoist equipment to place the jacking beam on rails inside runways of the lift.
- Adjust the telescopic base to the correct width.
- Check to make sure that all four rollers are seated properly on rails as shown.
- Make sure that rail channel is clean of debris.
- Raise the lift up off the ground so that the jacking beam is off the ground.
- Check the clearance and movement of the jacking beam by sliding it forward and rearward on the rails.
- Check all rollers are centered on the rails at all points along the rail's length.

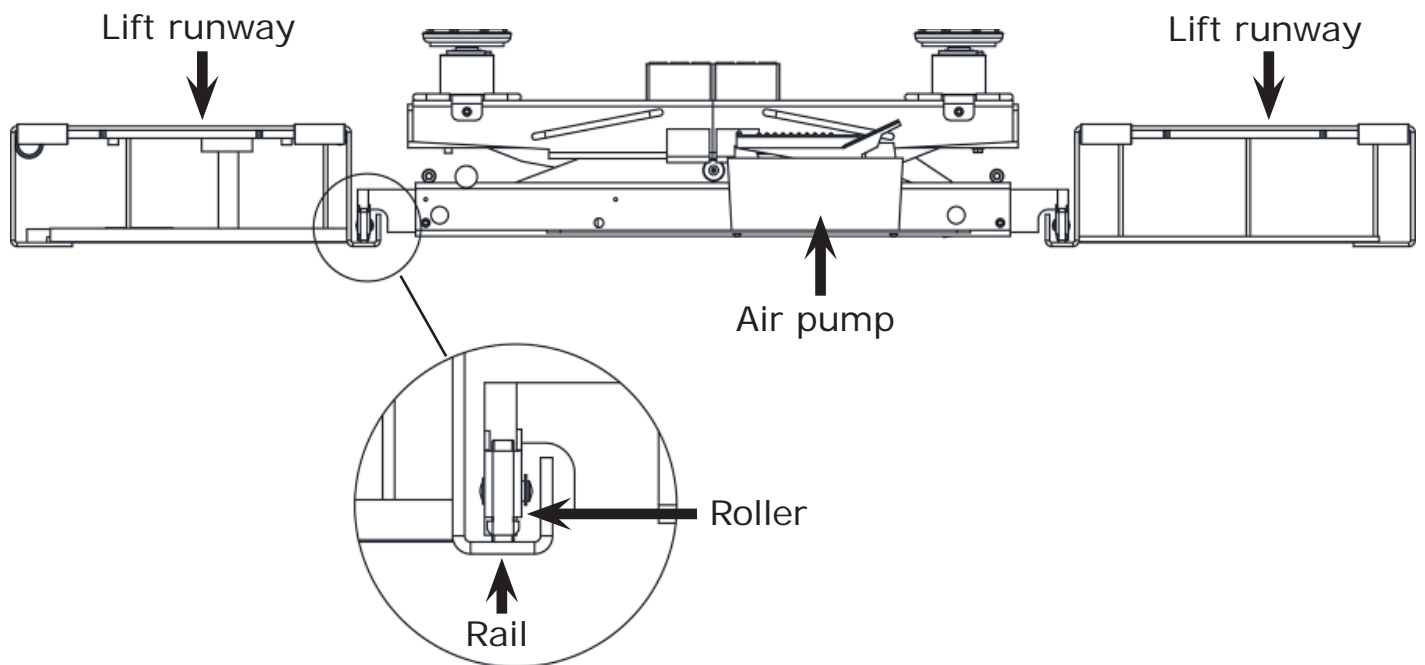



Fig. 3

3.2 Line Connection

	<p>When routing the hoses, make sure that the hoses are clear of any moving part.</p> <p>The pneumatic supply at site must be equipped with a servicing unit composed of water separator, lubricator and pressure reducer.</p> <p>The air pressure must be set at 6-8bar.</p>
---	--

- Connect the air pump to the pneumatic supply at site or the control valve (ref. fig. 4) if it is available on the lift using the supplied hose with the proper length cut.
- Connect the hydraulic hose following the figure 5.
- Tighten the fittings thoroughly.
- Fill the pump reservoir with the oil suggested by the air pump manufacturer.

Connect the
air pump to
this fitting

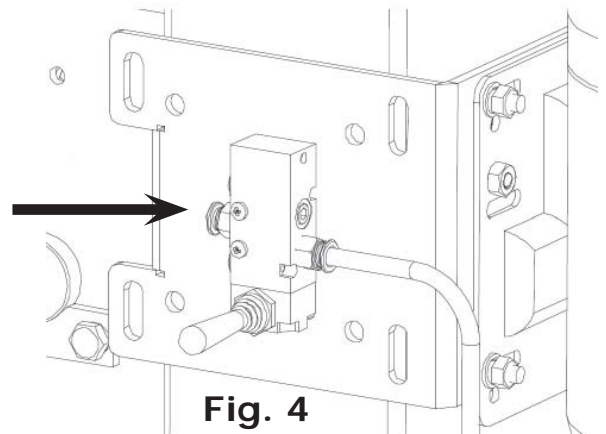

Fig. 4

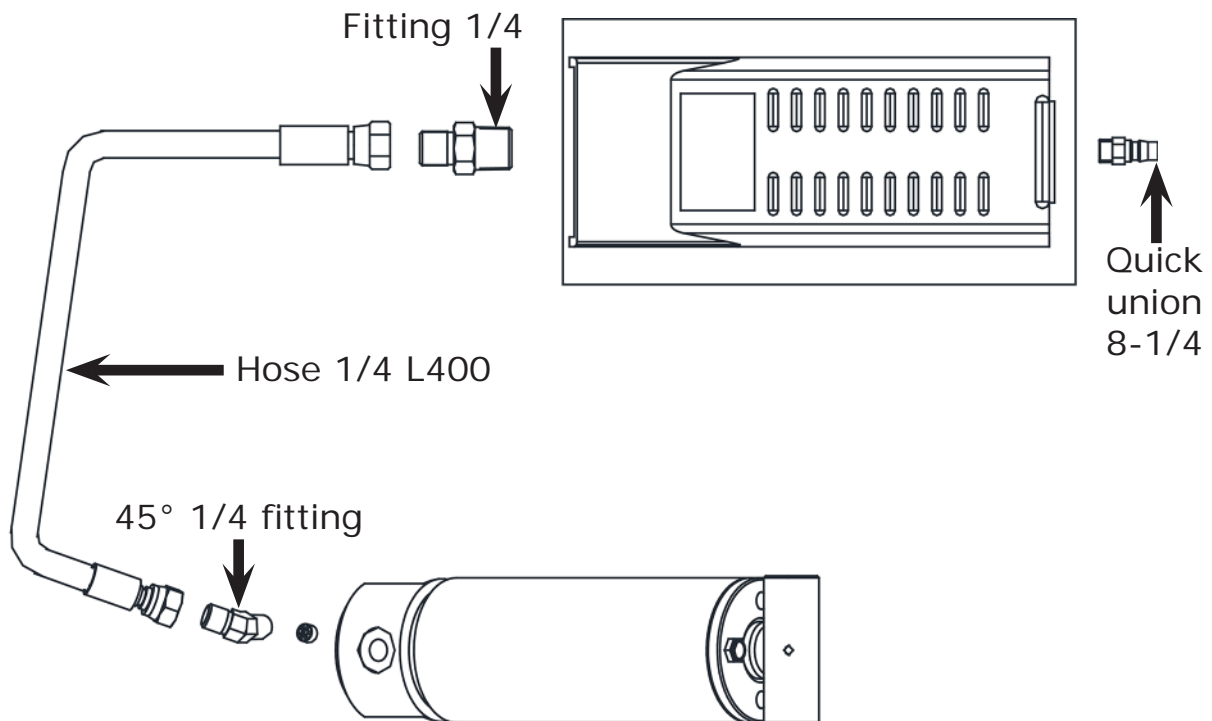

Fig. 5

3.3 Installation Check

- Check for hydraulic leaks.
- Check oil level in the pump reservoir.
- Check the pneumatic system for proper operation.
- Check for overhead obstructions.
- Check the lift runway level.
- Check all screws and Pins secured.
- Lubrication of critical components.



Never try to raise the jacking beam over the rated height.

Particularly, check the followings for proper operation:

- Without a vehicle loaded, depress the pedal of the pump to raise the jacking beam at the full stroke to check for the proper operation.
- Check for the first lock operation by lowering the jacking beam to the first lock position (about 444mm high), then raising the jacking beam to clear off the lock and in the meantime flipping the lock release handle up off the lock.
- Check for the second lock operation by lowering the jack to the second lock position (about 351mm high), then raising the jack to clear off the lock and in the meantime flipping the lock release handle up off the lock.

Operation And Use



Never operate the jacking beam with a person.

Never exceed the rated lifting capacity.

Never raise the jacking beam over the rated height.

Always ensure that the locks are engaged before any attempt is made to work on or near the vehicle.

Jack operation can be summarized into three steps:

4.1 Lifting

- Check and keep the rail channel clean of debris and any object that may hinder the movement of the jacking beam.
- Lower the jacking beam fully by depressing the lowering end of the pedal on the air pump.
- Adjust the width of the telescopic arms so that the rubber pads or the adaptors can contact the lifting points of the vehicle recommended by the vehicle manufacturer.
- Raise the jacking beam by depressing the lifting end of the pedal on the air pump. Keep an eye on the jacking beam when the rubber pads or the adaptors contact the vehicle to ensure the proper contact. Adjust the width of the telescopic arms if necessary.

4.2 Standing

- Stop raising the jacking beam just as vehicle is raised off the lift runways.
- Confirm the vehicle is stable and seated properly before lifting the vehicle to the desired height.
- After the vehicle is raised to the desired height, lower the jacking beam to the nearest lock.

4.3 Lowering

- Be sure the safety area is free of people and objects.
- Raise the jacking beam high enough to clear off the lock, then flip the lock release handle up off the lock.
- Lower the jacking beam fully by keeping pressing the lowering end of the pedal.

Maintenance



Only trained personnel who knows how the product works, must be allowed to service the product.

To service properly the product, the following has to be carried out:

- use only genuine spare parts as well as equipment suitable for the work required;
- follow the scheduled maintenance and check periods shown in the manual;
- discover the reason for possible failures such as too much noise, overheating, oil blow-by, etc. refer to documents supplied by the dealer to carry out maintenance:
- functional drawing of the electric and hydraulic equipment
- exploded views with all data necessary for spare parts ordering
- list of possible faults and relevant solutions.

9.1 Ordinary Maintenance

The product has to be properly cleaned at least once a month. Use self-cleaning clothes.



The use of water or inflammable liquid is strictly forbidden

Be sure the rod of the hydraulic cylinders is always clean and not damaged since this may result in leakage from seals and, as a consequence, in possible malfunctions.

9.2 Periodic Maintenance

Weekly	<ul style="list-style-type: none">• Lubricate all rollers with general purpose oil.• Lubricate the safety lock pivot pins with general purpose oil.• Check all hoses, bolts and pins to ensure the proper installation.• Check and tighten the cylinder bolt.
Monthly	<ul style="list-style-type: none">• Verify that all components and mechanisms are not damaged• check oil level in the pump reservoir; refill with oil, if needed;• Check for oil leakage.• Check oil for contamination or ageing. Contaminated oil is the main reason for failure of valves and shorter life of the pump.

Troubleshooting

A list of possible troubles and solutions is given below:

Trouble:	Possible Cause:	Solution:
Pump does not start when pedal is depressed, or pump starts but stalls under load.	Air supply is insufficient.	Check and set supply pressure at 6-8 bar.
	Airline has leakage	Check and connect airline properly.
	Pump is faulty.	Check and replace if necessary.
Pump runs but does not raise after contacting load.	Load is over capacity.	Use jack only to rated capacity.
	Hydraulic circuit has leakage.	Check and connect circuit properly.
	Oil in pump reservoir is not sufficient.	Add hydraulic oil.
	Pump is faulty.	Check and replace if necessary.
Pump runs but jack does not raise to full height.	Oil in pump reservoir is not sufficient.	Add hydraulic oil.
Jack does not lower	Lock is not released.	Release lock.

Part List

General Part List

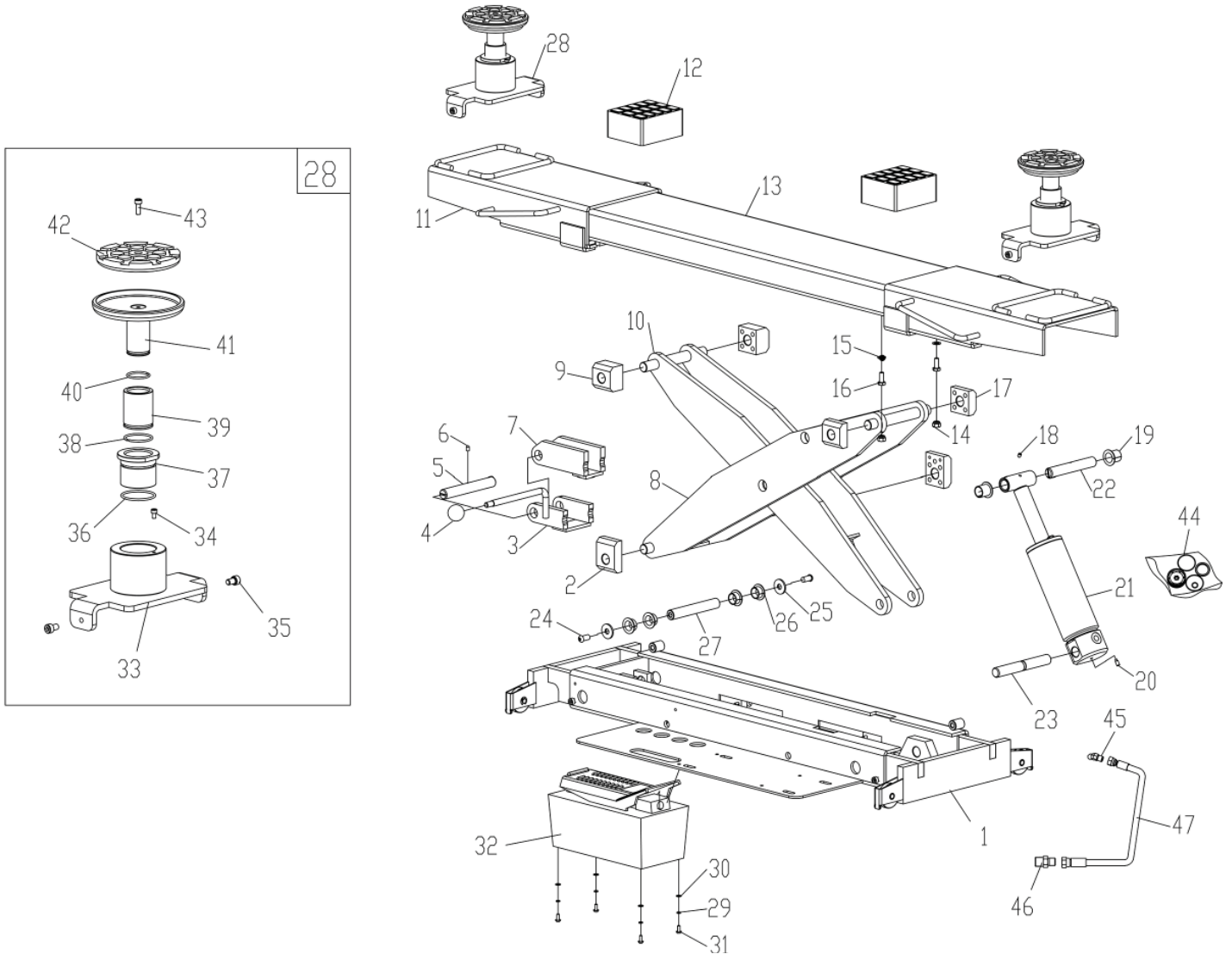

Item	Part number	Description	Qty
1	J07B100000	base assy.	1
2	J07B000003	Lower slider	2
3	J07B000200	Safety lock 2	1
4	0215017	Knob M10X33	1
5	J07B000005	Lock pin	1
6	0209010	Screw M6X10	1
7	J07B000100	Safety lock 1	1
8	J07B200000	Outer scissor arm	1

Item	Part number	Description	Qty
9	J07B000001	Upper slider 1	2
10	J07B300000	Inner scissor arm	1
11	J07B500000	Telescopic arm	2
12	0606033	Rubber pad 115X100X55	4
13	J07B400000	Upper beam	1
14	0204004	Self-locking nut M8	2
15	0205008	Washer D.8	2
16	0201043	Screw M8X20	2
17	J07B000002	Upper slider 2	2
18	0209030	Screw M6X8	1
19	0210089	Bush SF-1/2024F	2
20	0209002	Screw M6X10	1
21	J07BY63000	Hydraulic cylinder	1
22	J07B000007	Cylinder upper shaft	1
23	J07B000006	Cylinder lower shaft	1
24	0206069	Screw M10X20	2
25	J07B000008	Washer	2
26	0210086	Bush SF-1/2012F	4
27	J07B000004	Middle shaft	1
28	J07B600000	Arm adaptor	2
29	0208003	Locking washer D.5	4
30	0205004	Washer D.5	4
31	0206041	Screw M5X12	4
32	0301052	Air pump 1.6L	1
33	J07B600100	Adaptor base	2
34	0202020	Screw M5X8	2
35	0202043	Screw M8X12	4
36	0309091	O-ring 45X2.65	2
37	Z23A313002	Outer thread bush	2
38	0212034	Seeger D.42	2
39	Z23A313001	Inner thread bush	2
40	0212035	Seeger D.32	2
41	Z23A313100	Pad tray	2
42	Z23A313202	Round rubber pad	2
43	0202032	Screw M6X16	2
44	J07BY6300S	Cylinder seal kit	1
45	0303020	45° 1/4 fitting	1
46	0303064	Quick union 8-1/4	1
47	ZZ400	Hyd. hose 1/4 L400	1

Base Assembly

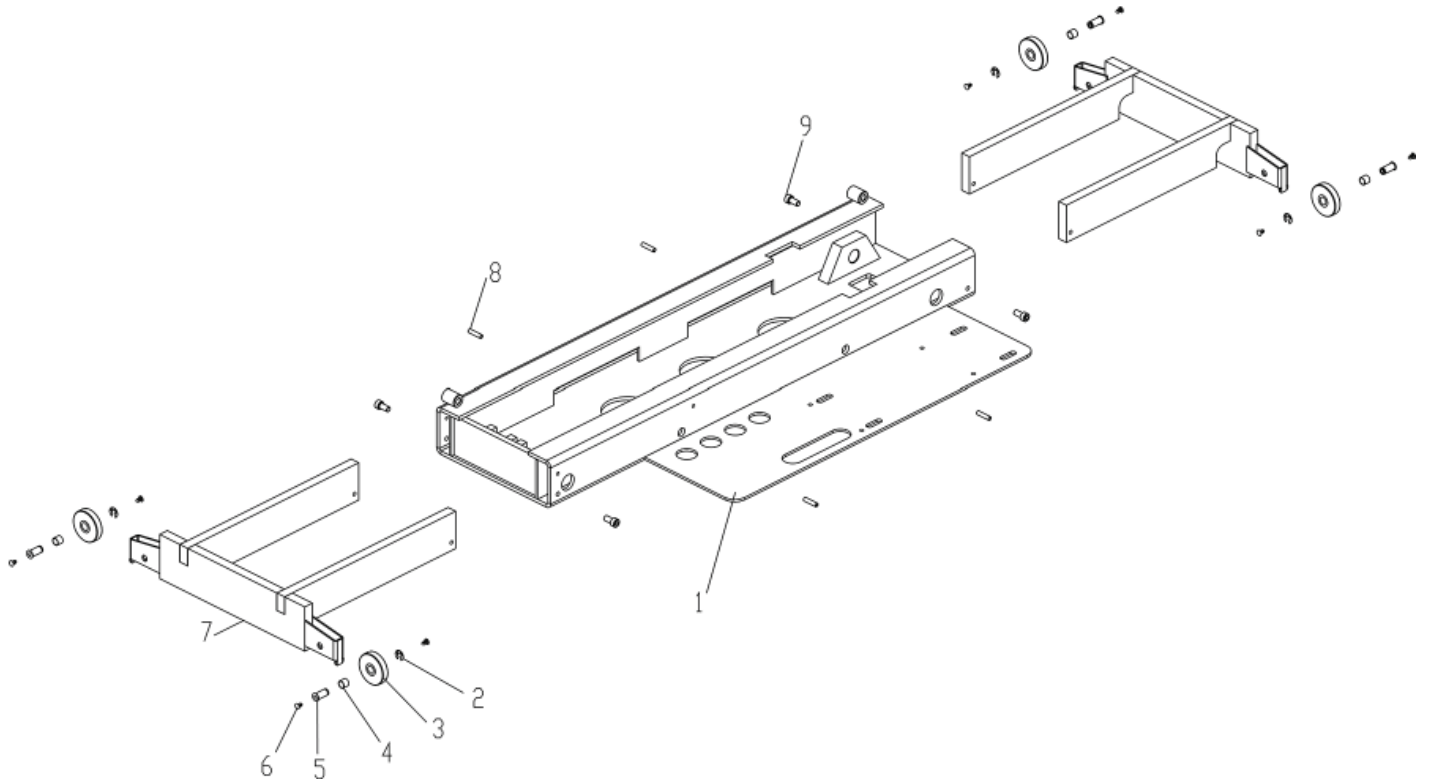

Item	Part number	Description	Qty
1	J07B110000	Jack base	1
2	0211015	Seeger D.8	4
3	J07B100100	Roller	4
4	0511172	Bearing 1010	4
5	J07B100001	Roller shaft	4
6	0511173	Nylon pin	8
7	J07B120000	Telescopic base	2
8	0213109	Elastic pin 6X25	4
9	0202040	Screw M8X16	4