

WHIP INDUSTRIES, INC.

WFP30R, WFP30R-E & WFP30R-EE

STD., EXT. & E-EXT.

30,000 LBS CAPACITY

FOUR POST ABOVE GROUND LIFT

INSTALLATION INSTRUCTIONS & MANUAL

WHIP INDUSTRIES, INC
3010 S MAIN ST.
FORT WORTH, TEXAS 76110
PH (800) 256-7391 FAX (817) 289-1412
E-MAIL: WhipInd@whipindustries.com

Rev. B

TABLE OF CONTENTS

Important Information	3
Cautions and Warnings	3
Tools Required	4
Anchoring Tips	5
Installation Instructions	6
30 Day Maintenance	9
Trouble Shooting Guide	9
Parts & Shipping List	11
Parts Breakdown and Installation Drawings	14

IMPORTANT INFORMATION

1. The floor where the lift is to be installed must be a minimum of 4” thickness of concrete. Concrete must be reinforced with steel rebar with a minimum compressive strength of 3,000 psi . Failure by the purchaser to provide the recommended mounting surfaces could result in personal injury, property damage and/or unsatisfactory lift performance.
2. Read the installation manual before installing the lift.
3. This lift is a four post lift which requires a minimum (STD.) 15’-6” x 30’-0” or (EXT.) 15’-6” x 35’-0” bay area. If 3 feet track extensions are purchased then increase the length in increments of the 3’-0” depending on the number of extensions purchased. If only one set is purchased, the preference of the manufacture is to install them at the ramp end of the lift.
4. Read anchoring tips information before drilling and installing the anchor bolts.
5. Do not raise a vehicle with the lift until the lift has been correctly installed and adjusted as described in this manual.
6. Maximum floor variation between any two posts is 2 inches.
7. Regulator should be set at 110 psi.

CAUTIONS AND WARNINGS

MOTORS AND ELECTRIC CONTROLS ARE NOT – SEALED AGAINST WEATHER OR MOISTURE. DAMAGE OR ELECTRICAL SHOCK MAY OCCUR IF INSTALLED UNPROTECTED OUTDOORS.

FACTORY MUST BE NOTIFIED WITHIN 30 DAYS OF DELIVERY IF THERE ARE ANY PARTS MISSING FROM SHIPMENT.

RECOMMENDED OIL: HYDRUALIC MEDIUM OIL SAE-10 OR EQUIVALENT. MAY USE TRANSMISSION FLUID.

ALL BOLTS PLACED IN THE COLUMN MUST BE PLACED FROM THE OUTSIDE FACING INWARD. UNLESS NOTED IN THE INSTALLATON INSTRUCTIONS.

TOOLS REQUIRED

Concrete rotary hammer drill with ¾" carbide bit

Open End Wrenches: 7/16", 1/2", 9/16", 11/16", 3/4" & 1 1/8"

Ratchet Driver

Sockets: ¼", 1/2", 3/4" X 1/2" deep

Allen Wrenches: 3/16", 1/4" & 5/16"

12" Crescent Wrench

Hammer

Needle Nose Pliers

Retainer Ring Pliers

Electrical Pliers

Level

Fish Tape

25' Tape Measure

Chalk Line

Small Drift Punch

Step Ladder

6 gallons of hydraulic medium oil SAE-10 or equivalent

¼" Pneumatic Hose

4 x 4 Wood Blocks

#19 Steel Drill (0.166 Dia.)

ANCHORING TIPS

1. Anchor must be at least 5" from the edge of the slab or any seam.
2. Use a concrete hammer drill with a 3/4" carbide bit.
3. Do not use a worn bit.
4. Drill in a perpendicular line with the hole.
5. Do not apply excessive pressure to the drill. Let the drill do the work.
6. Lift the drill up and down occasionally to remove residue and to reduce binding.
7. Drill the hole depth equal to the length of the anchor, or completely through the slab.
8. For better holding power, blow all dust and residue from the hole before driving anchor into hole.

Place a flat washer over threaded end of anchor. Spin nut 1/2" down past end of anchor. Carefully tap anchor into the concrete until nut and flat washer are against base plate. Do not use an impact wrench to tighten.

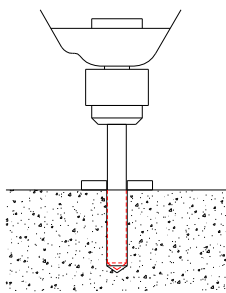

FIG. #1

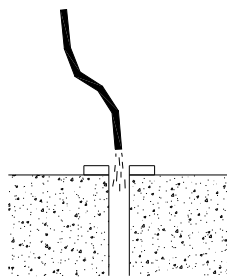

FIG. #2

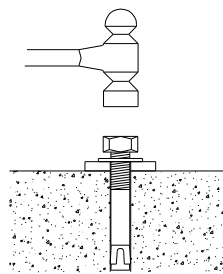

FIG. #3

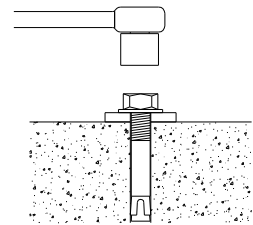

FIG. #4

INSTALLATION INSTRUCTIONS

1. Standard area required for four post alignment lift is a minimum of (STD.) 15'-6" x 30'-0" or (EXT.) 15'-6" x 35'-0" area. If 3 feet track extensions are purchased then increase the length in increments of the 3'-0" depending on the number of extensions purchased. If only one set is purchased, the preference of the manufacture is to install them at the ramp end of the lift.
2. Using the chalk line layout a rectangle (STD.) 12'-5 1/2" x 21'-5 1/4" or (EXT.) 12'-5 1/2" x 26'-5 1/4" at least 3'-2" from the ramp location and 1'-6 1/4" from either side of the lift (see Layout & Installation Specification sheet). This should give the lift 4" clearance in front of the ramps and 1'-6 1/2" from the side of the any leg.
3. Unpacking lift, inspect lift for any damages due to transportation and check shipping list for missing parts.
4. Determine the location for the lift. Keep in mind overhead clearances. Sixteen feet is the minimum recommended ceiling height. A higher ceiling may be required depending the height of the vehicles.
5. Determine which side of the lift the Top Rail and power unit is to be installed. This is called the MAINSIDE. The other side is referred to as the OFFSIDE. Ease of entry and exit from vehicles, type of work being done, and required placement of the power unit on the Top Rail side are all considerations.
6. After determining the Mainside (the side the Top Rail is to be placed on), stand the two Mainside Legs upright inside the chalk lines, with each leg facing inside. One of the two legs comes with factory installed power unit mounts. This leg is to be placed as follows: If Top Rail/Mainside is to be on the right as you approach, this post must be at the right front corner. (See Installation Specs & Layout Drawing.) If Top Rail/Mainside is to be on the left as you approach, this post must be the left rear corner. (Optional Mainside Leg Location) This manual will show the Top Rail/Mainside being on the right side.
7. With both Mainside Legs on the chalk lines, Step #1 (see Fig. #5A) is to drill holes using a 3/4" diameter carbide drill bit. (Hold the (STD.) 20'-5 1/2" or (EXT.) 25'-5 1/2" dimension of the legs center to center.) Keep in mind the anchoring tips mentioned previously in the manual. After drilling all 8 hole on the Mainside Legs, anchor them down with 3/4-10UNC 5 1/2 anchor bolts (8 pcs. - 91578A501). Make sure legs are level and plumb. Make sure all bolts are properly set and meet 75 ft. lbs of torque. **DO NOT USE AN IMPACT.**
8. Locate Top Rail assembly as shown in Fig. #1. Step #2 is to mount Top Rail assembly on top of Mainside Legs (see Fig. #5A & #5B). Secure Top Rail to Mainside Legs using 1/2-13UNC x 2 HHCS (8 pcs. - 91247A720), 1/2 flat washers top and bottom (16 pcs. - 90126A033), 1/2 lock washers (8 pcs. - 91102A033) & 1/2-13UNC hex nut (8 pcs. - 90473A223).

9. Next locate a Cross Rail assembly. Use a fish tape to pull the Cross Rail chain through the Cross Rail tube. The chain runs under the roller on the offside and over the roller on the Mainside. Repeat with the other Cross Rail. Feed the fish tape through the Cross Rail starting from the Mainside by going over the Mainside roller and through the Cross Rail tube, then under the Offside roller and straight up. (See Fig. #3)
10. Step #3 is to set Cross Rails on two 4 x 4 blocks at each end in front of Mainside Legs, with the machined Cross Rail connector towards the Mainside Leg as shown in Fig. #3 & #5A.
11. Next using the 3/8 x 1 1/2 shoulder screw provided, connect the Cross Rail chain to the chain anchor welded to the base plate of the Mainside Leg (see Fig. #5C). Next move the Cross Rail over the chain connector. IMPORTANT – The chain must be in a vertical position. It cannot be cocked towards the front or rear of the chain anchor (See Fig. #5C)
12. Step #4, repeat steps #3 on the other Mainside Leg and Cross Rail.
13. Step #5, position each Offside Leg about 6” from the end of each Cross Rail, and put a 4 x 4 board under each Cross Rail.
14. Step #6, connect threaded chain connector to free end of chain using the 3/8 x 1 1/4 shoulder screw provided (see Fig. #5D). Run threaded chain connector into the hole from the inside to the top of Offside Leg. Run 2 – 1 1/8-12UNF hex nut all the way down until connector is flush with the top of the hex nut. Repeat step #5 & #6 on other Cross Rail.
15. Step #7, Move Offside Legs inside chalk line hold 20’-5 1/2” from center to center of legs. You can go ahead and drill the holes for the anchor bolts on the Offside Leg per the Anchoring Tip Sheet. Leave the bolts loose until the legs are plumbed and the lift is operating without getting in a bind.
16. Step #8, extend hydraulic cylinder, which lower both Top Rail chain to connect them to the chain connectors on Cross Rail (see Fig. # 5E). This is done by removing the breather from rear of the cylinder as shown in see Fig. #1. Pull on the chain to extend the cylinder rod. Use the 3/8 shoulder screw (2 pcs. – 91259A640) and 5/16-18UNC nylon lock nut (2 pcs. – 90640A130) to secure the chain. Do not substitute this bolt! Repeat on other Cross Rail. Then place breather back on cylinder.
17. Step #9 is to mount the power unit to the Mainside Leg with the mounting brackets using 5/16-18UNC x 1” bolts, 5/16-18UNC hex nuts and 5/16 lock washers respectively. Then connect power unit to the hydraulic cylinder using a 3/8 hydraulic hose (ALIF-412-029). Next connect the electricity to the power unit. Power requirements: 230 Volt, single-phase power, and 29 amps. Requires a minimum of 10-gage wire (prefer 8-gage wire). Use separate circuit for each unit and protect each circuit with 30-amp time delay fuse or circuit breaker.

18. Fill pumping unit with hydraulic medium oil SAE-10 or equivalent. It will take approximately 6 US gallons. May use automatic transmission fluid.
19. Step #10 is to connect the 3/8 hydraulic hose from the power unit to the cylinder. Next secure the 3/8 hydraulic hose using the 3/4 rubber cushion steel loop (4 pcs. – 3225T6) and #10 x 1/2 self-threading screws (4 pcs. - 90096A242) (see Fig. #6B). A #19 drill is used to drill the holes for the #10 self-threading screws.
20. Step #11 is to connect the pneumatic control valve to the 1 1/16 diameter cylinders using the components shown in Fig. #6a & #6B. Secure the 5/32 black tube next to the control valve with a 1/4 plastic loop and a #10 self-threading screw. NOTE: Regulator should be set at 110 psi.
21. Before operating lift visually inspect lift to make sure the chains and hoses are not rubbing on hardware or lift parts. Also make sure long chain is not twisted inside Top Rail tube. **DO NOT TIGHTEN THE ANCHORS ON THE OFFSIDE LEGS YET.**
22. Step #12 is to locate the Track Weldm't. (STD. 2 pcs. - ALIF-430-037-XX) or (EXT. 2 pcs. - ALIF-430-237) and position them on top of the Cross Rails as shown in Fig. #5F. Hold 62" inside Track Weldm't. and centered on the Cross Rails side to side. Position tracks on the Cross Rails about 6 1/2" from the safety latches. Raise the lift up about 12". Place a level on the Cross Rail and level the Cross Rail by adjusting the nut on the Offside Leg threaded chain connector.
23. After leveling Cross Rails, adjust and plumb the Offside legs so that the Cross Rail chains in the Offside legs hang straight. Use a level. Cycle the lift all the way up and down making sure that each corner is running freely. The Offside legs may vary from being plumb slightly. It is more important that the lift moves up and down freely. Adjust and plumb Cross Rails and legs as necessary by shimming the base plate. When you are positive the lift is moving freely, you may finally tighten the anchor bolts in the Offside Legs. After tightening the anchor bolts cycle the lift to make sure the lift is still moving freely.
24. Step #13, finish the track assembly (see Fig. #4A). Locate and install track clamps front stops, ramp bracket and pin ramp assembly. If 3 feet track extensions are purchased with lift then see Fig. #4B. Track extensions may be purchased for both ends or just one end of the lift. If only one set is purchased, the preference of the manufacture is to install them at the ramp end of the lift.
25. Raise and lower lift repeatedly to purge air trapped in hydraulic lines and to adjust Cross Rails. Each Cross Rail must be synchronized as the lift moves up and down.
26. Refill tank with hydraulic oil and lift is ready to operate.

30 DAY MAINTENANCE

- 1) Check all bolts and nuts to make sure they are tight.
- 2) Check equalizer chains regularly for proper tension and adjustment.
- 3) Inspect adapters and pads for damage or wear. Replace if necessary.
- 4) Inspect all hydraulic lines and fittings for leaks and tighten if necessary.
- 5) Check locking latches and releases for proper operation.
- 6) Check automatic arm lock device for proper operation.
- 7) During first week check and tighten anchor bolts daily and check concrete for stress cracks

TROUBLE SHOOTING GUIDE

POSSIBLE PROBLEM

POSSIBLE CAUSE & SOLUTIONS

1. MOTOR DOES NOT RUN

- A) Breaker tripped or fuse blown
- B) Motor thermal overload tripped. Wait for overload to cool.
- C) Check thermal overload in starter box (three phase only). Push to reset.
- D) Defective control switch, replace
- E) Faulty wiring connections. Call electrician.

2. MOTOR RUNS BUT THE LIFT WILL NOT RAISE OR HOLD A LOAD

- A) A foreign object under check valve. Push handle down and push "raise" switch. Foreign matter should release under pressure.
- B) Remove check valve. Clean and replace.
- C) Oil level low: check oil reservoir. With carriage in the down position, pump reservoir should be full.

3. MOTOR RUNS BUT THE LIFT PICKS UP PARTIAL LOAD ONLY.

- A) Relief valve setting is too low. Remove back hexcap on pump and adjust valve clockwise.

4. OIL BLOWS OUT BREATHER

5. LIFT MAKES A GROANING SOUNDING WHEN RAISING OR LOWERING.

6. LIFT RAISES UNEVENLY

B) Hydraulic seals damaged (call factory for instructions)

A) Oil reservoir overfilled

B) Lift lowered too quickly while under heavy load.

A) Bleed cylinder manually.

B) Add an ounce of oil to the air side of the piston.

A) Chain are not properly adjusted or tightened.

B) Use lighter weight oil in the pump.

PARTS & SHIPPING LIST

PART NUMBER	DESCRIPTION	QTY.	
	Ramp Assy.	2	
5304ZZ	52 O.D. x 20 I.D. x 22W DS Bearing	4	
90126A036	3/4 SAE Flat Washer	4	
90126A037	7/8 SAE Flat Washer	2	HK
98410A128	3/4 Dia. Retainer Ring	4	
98410A131	7/8 Dia. Retainer Ring	2	HK
ALIF-430-062-XX	Ramp Weldm't.	2	PKG
ALIF-430-065-XX	Ramp Bracket	2	PKG
ALIF-430-067-XX	7/8 Dia. Ramp Pivot Pins	2	PKG
	Top Rail Assy.	1	
SPL-6003	3/8 I.D. X 3/8 M NPT Push On 90 degree conn.	1	
2501-06-06	0.375MJIC x 0.375MNPT 90 Deg. Adapter	1	
90640A130	5/16-18UNC Nylon Lock Nut	2	
91259A640	3/8 Dia. x 4 Lg. Shoulder Screw	2	
98410A242	1 3/8 Dia. Ext. Retainer Ring	4	
98296A377	1/4 x 2 Spring Pin	2	
AA5015001	5.00 Dia. 60" Stroke Hyd. Cylinder	1	
ALIF-430-027-XX	STD.-Top Rail Weldm't.	1	
(ALIF-430-227-XX)	EXT.-Top Rail Weldm't.	1	
ALIF-430-080	Top Rail Pin	4	
ALIF-430-081	Cylinder Pin	1	
ALIF-430-083	Cylinder Chain Connector	1	
ALIF-430-085	STD.-BL834, 91 Pitch Male Ends, Short Top Rail Chain	2	
ALIF-430-086	STD.-BL834, 325 Pitch Male Ends, Long Top Rail Chain	2	
GL-12-056	4" Dia. Chain Sheave	8	
3225T6	3/4 Rubber Cushion Steel Loop	4	HK
90096A242	#10-24 x 0.50 Self Threading Screw	4	HK
90126A033	1/2 SAE Flat Washer	16	HK
90473A223	1/2-13UNC Hex Nut Grd. 2	8	HK
91102A033	1/2 Lock Washer	8	HK
91247A720	1/2-13UNC x 2 Lg. HHCS Grd. 5	8	HK
	Cross Rail Assy.	2	
ALIF-412-026	Anti-Sway Rub Block	4	PKG
ALIF-430-018L-XX	LH Cross Rail Weldm't.	1	
ALIF-430-018R-XX	RH Cross Rail Weldm't.	1	
ALIF-430-054-XX	Safety Latch Weldm't.	4	
ALIF-430-071-XX	Anti-Sway Bracket	4	PKG

ALIF-430-074	Cylinder Bosses	8	PKG
ALIF-430-076	Safety Latch Pin	4	
ALIF-430-078	Cross Rail Bearing Pin	4	
ALIF-430-084	Cross Rail Chain Connector	2	
ALIF-430-087	BL834, 216 Pitch M & F Ends, Cross Rail Chain	2	PKG
GL-12-056	4" Dia. Chain Sheave	4	
SPC-2501	5/32 Straight Push-On Fitting	4	
6498K43	Clevis, Pin & Ext. Retainer Ring	4	
6498K337-2.00	1 1/16 Dia. x 2" Stroke Cylinder	4	
90126A031	3/8 SAE Flat Washer	8	HK
90640A130	5/16-18UNC Nylon Lock Nut	6	HK
91102A030	5/16 Lock Washer	8	
91102A031	3/8 Lock Washer	8	HK
91251A583	5/16-18UNC x 1 Lg. SHCS	8	
91251A623	3/8-16UNC x 7/8 Lg. SHCS	8	HK
91259A626	3/8 x 1 1/4 Lg. Shoulder Screw	2	HK
91259A628	3/8 x 1 1/2 Lg. Shoulder Screw	2	HK
91259A640	3/8 x 4 Lg. Shoulder Screw	2	HK
98410A133	1 Dia. Retainer Ring	4	
98410A249	1 3/8 Dia. Retainer Ring	4	
	LH/RH Mainside Leg Assy.	1/1	
	Offside Leg Assy.	2	
91102A030	5/16 Lock Washer	4	HK
91247A583	5/16-18UNC x 1.0 Lg. HHCS Grd. 5	4	HK
91578A501	3/4-10UNC x 5 1/2 Wedge Anchor w/Nut & Washer	16	HK
94846A558	1 1/8-12UNF Jam Nut Grd. 5	4	HK
95473A030	5/16-18UNC Hex Nut Grd. 2	8	HK
ALIF-430-008-XX	Offside Leg Weldm't.	2	
ALIF-430-009-XX	Main Side Leg Weldm't. w/ PU Mounts	1	
ALIF-430-010-XX	Main Side Leg Weldm't. w/o PU Mount	1	
ALIF-430-082	Threaded Chain Connector	2	PKG
	Track Assy.	2	
ALIF-430-037-XX	STD.-Track Weldm't.	2	
(ALIF-430-237-XX)	EXT.-Track Weldm't.	2	
ALIF-430-038-XX	Track Stop	2	PKG
ALIF-430-039-XX	Track Clamp	2	PKG
90126A036	3/4 Flat Washer	40	HK
90473A237	3/4-10UNC Hex Nut	24	HK
91102A036	3/4 Lock Washer	24	HK
91247A846	3/4-10UNC x 2 3/4 Lg. HHCS Grd. 5	16	HK
92865A841	3/4-10UNC x 1 3/4 Lg.. HHCS Grd. 5	8	HK

Misc. Parts

3225T6	¾ Rubber-Cushion Steel Loop	4	HK
414411000	Pneumatic Control 3-Way Valve	1	HK
50785K41	1/8MNPT x 1/8FNPT 90 Deg Street Elbow	1	HK
5402-02-04	1/8MNPT x 1/4FNPT Straight Expander	1	HK
5485K22	¼ MNPT Hex Nipple	1	HK
6534K46	¼ MNPT Pneumatic Hose Coupling	1	HK
6801-LL-06-06	3/8 MJIC x 3/8 MORB 90 Deg. Fitting	1	HK
8876T13	¼ Nylon Loop Strap	1	HK
90096A242	#10-24 x ½ Lg. Self Threading Screw	5	HK
91102A002	#8 Lock Washer	3	HK
91251A199	#8-32UNC x 1 Lg. SHCS	3	HK
AH-1009	Power Unit	1	PKG
ALIF-412-029	0.375FJIC Hose x 108"	1	PKG
GL-09-056	1/16" Steel Shims	16	HK
GL-09-112	¼" Steel Shims	12	HK
PT23003BK	5/32 O.D. Black Tube	56'	PKG
SPE-25	5/32 Push-On Union Tee	3	HK
SPL-2501	1/8MNPT x 5/32 90 Deg. Push-On Fitting	1	HK

Optional Parts

ALIF-430-EXTKIT	3 Ft. Track Extension Kit	1	
ALIF-430-048-XX	3 Ft. Track Ext.	2	PKG
90126A036	¾ Flat Washer	24	HK
90473A237	¾-10UNC Hex Nut	12	HK
91102A036	¾ Lock Washer	12	HK
91247A846	¾-10UNC x 2 ¾ Lg. HHCS Grd. 5	4	HK
91257A844	¾-10UNC x 2 ¾ Lg. HHCS Grd. 8	8	HK
WAJ15	15K Air Roller Jack	1	PKG

*** Note: All hardware unless specified is grade 2. All hardware is zinc coated unless specified. Parts with PKG at the end are packed on the lift and parts with HK at the end are packaged in a box and put on the lift.

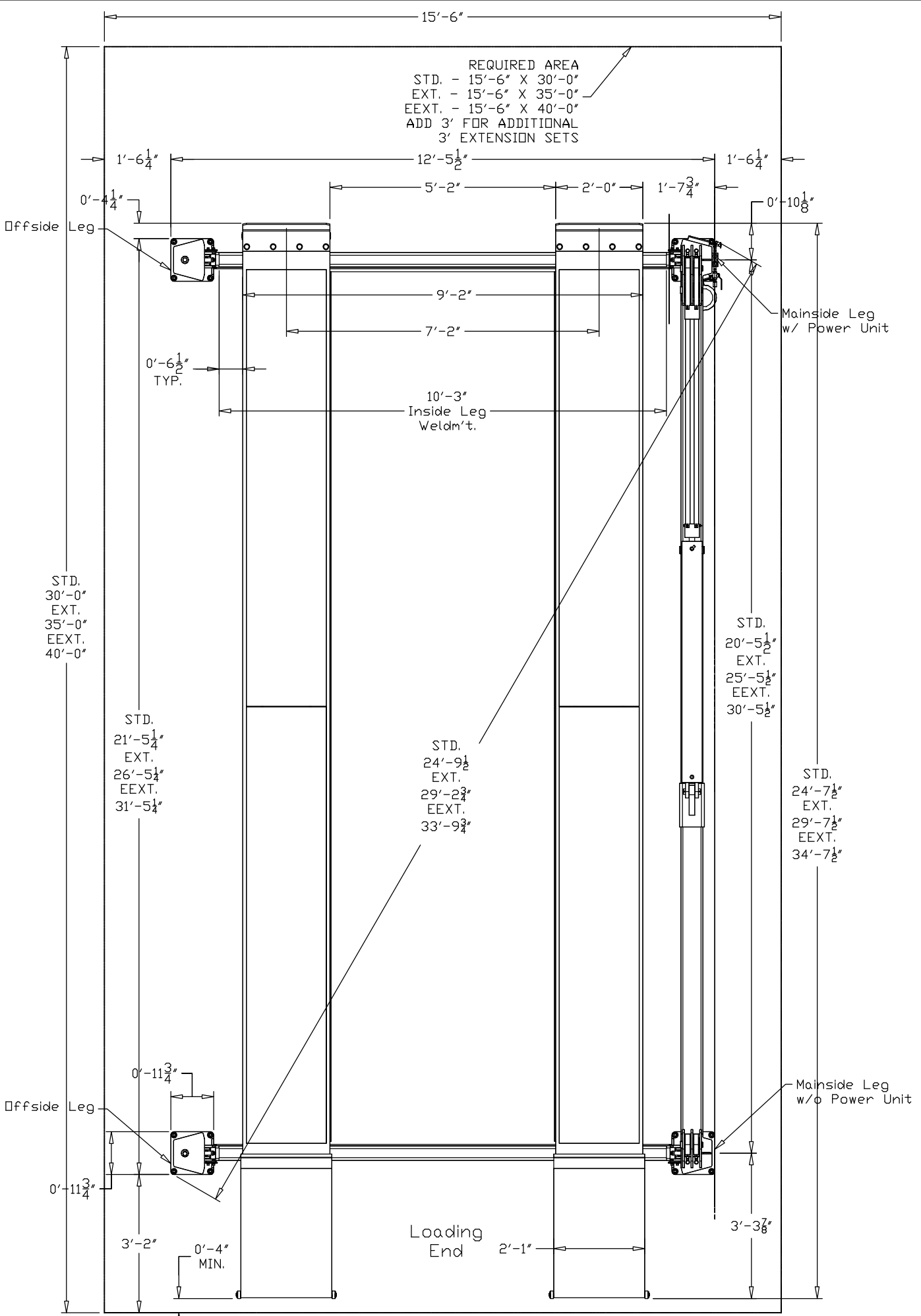

INSTALLATION SPECIFICATION
& LAYOUT DRAWING

TOP RAIL ASSY.

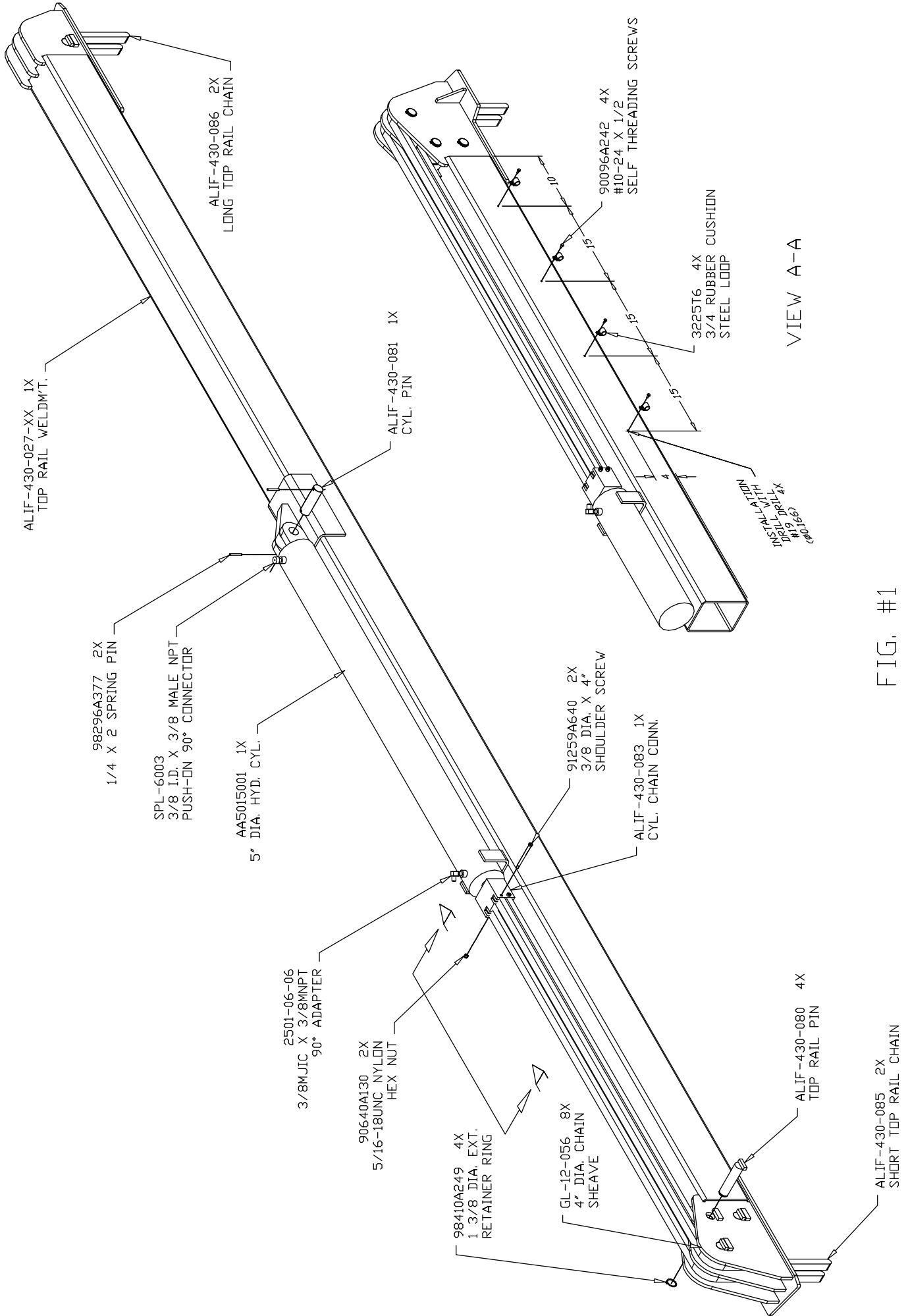

FIG. #1

LEG ASSEMBLY

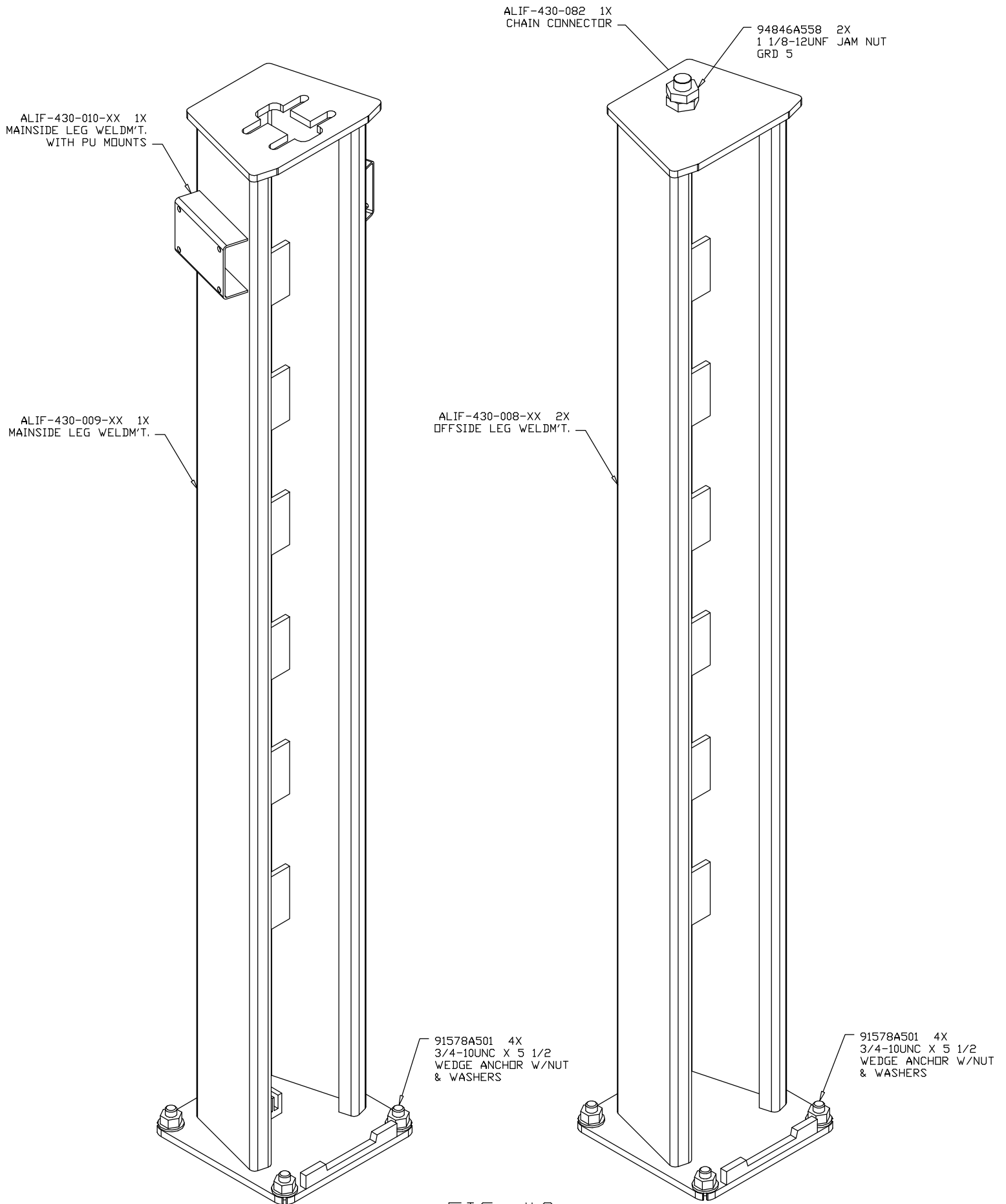
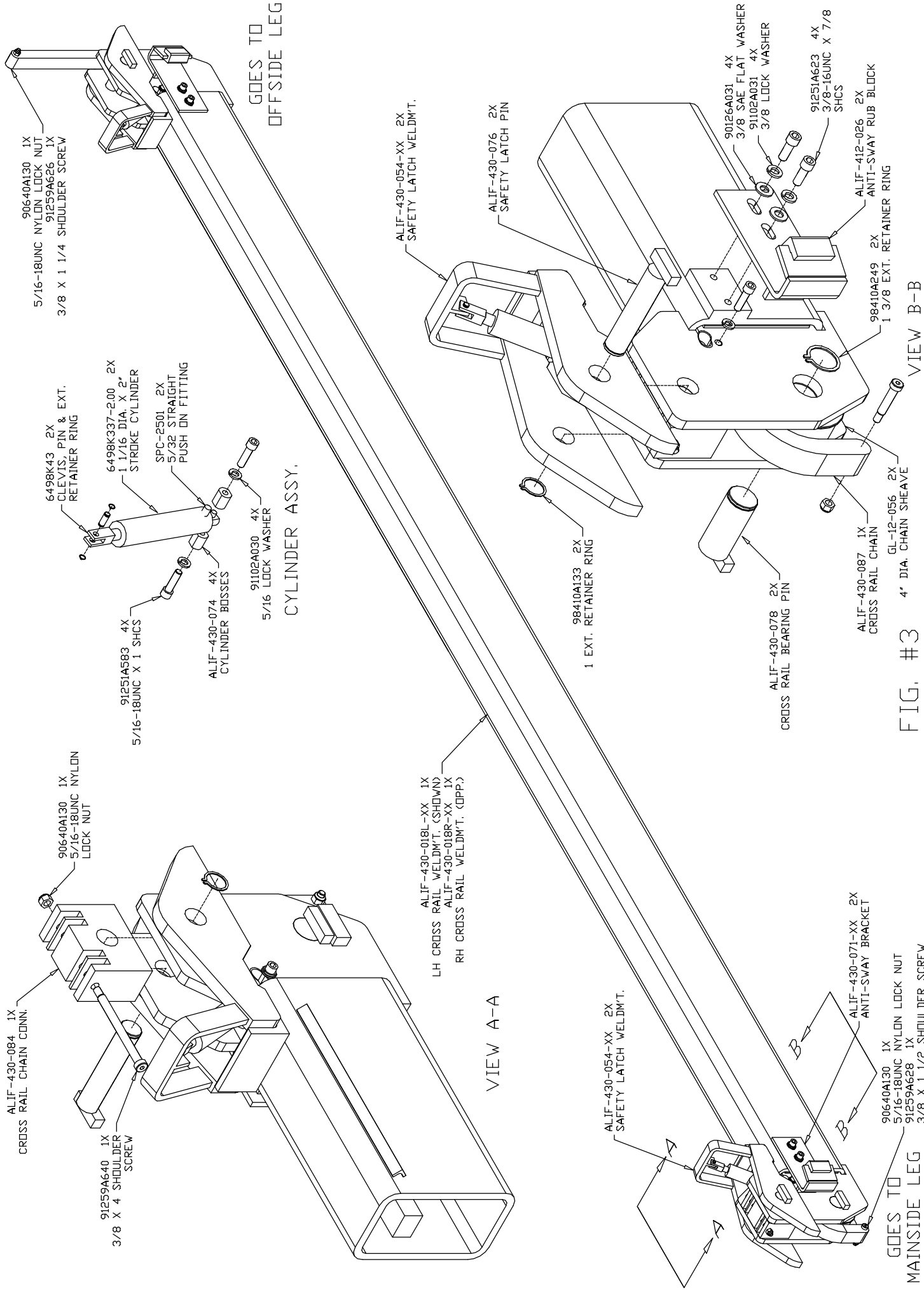

FIG. #2

CROSS RAIL ASSEMBLY



ALIF-430-084 1X
CROSS RAIL CHAIN CONN.

91259A640 1X
3/8 X 4 SHOULDER
SCREW

90640A130 1X
5/16-18UNC NYLON
LOCK NUT

90640A130 1X
5/16-18UNC NYLON LOCK NUT

91259A626 1X
3/8 X 1 1/4 SHOULDER SCREW

6498K43 2X
CLEVIS, PIN & EXT.
RETAINER RING

6498K337-2.00 2X
1 1/16 DIA. X 2" STROKE CYLINDER

SPC-2501 2X
5/32 STRAIGHT PUSH ON FITTING

91251A583 4X
5/16-18UNC X 1 SHCS

ALIF-430-074 4X
CYLINDER BOSSES

91102A030 4X
5/16 LOCK WASHER

CYLINDER ASSY.

GOES TO
OFFSIDE LEG

ALIF-430-054-XX 2X
SAFETY LATCH WELDMT.

VIEW A-A

ALIF-430-018L-XX 1X
LH CROSS RAIL WELDMT. (SHOWN)

ALIF-430-018R-XX 1X
RH CROSS RAIL WELDMT. (DPP)

ALIF-430-076 2X
SAFETY LATCH PIN

98410A133 2X
1 EXT. RETAINER RING

ALIF-430-054-XX 2X
SAFETY LATCH WELDMT.

90126A031 4X
3/8 SAE FLAT WASHER

91102A031 4X
3/8 LOCK WASHER

91251A623 4X
3/8-16UNC X 7/8 SHCS

ALIF-430-078 2X
CROSS RAIL BEARING PIN

ALIF-412-026 2X
ANTI-SWAY RUB BLOCK

98410A249 2X
1 3/8 EXT. RETAINER RING

ALIF-430-087 1X
CROSS RAIL CHAIN

90640A130 1X
5/16-18UNC NYLON LOCK NUT

91259A628 1X
3/8 X 1 1/2 SHOULDER SCREW

GOES TO
MAINSIDE LEG

VIEW B-B

GL-12-056 2X
4" DIA. CHAIN SHEAVE

FIG. #3

TRACK, RAMP & STOP ASSEMBLY

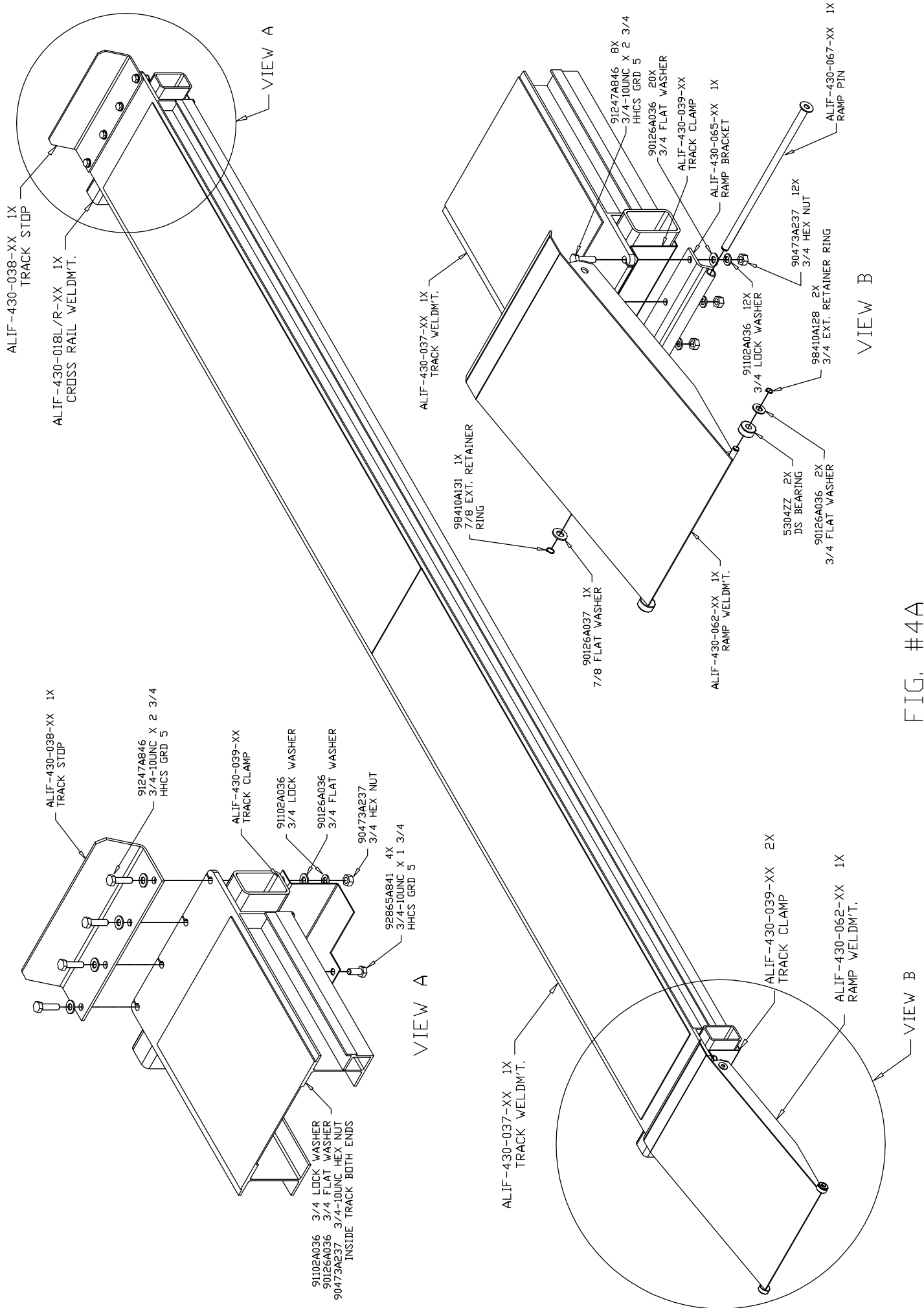

FIG. #4A

3 FT. TRACK EXT., TRACK, RAMP & STOP ASSEMBLY

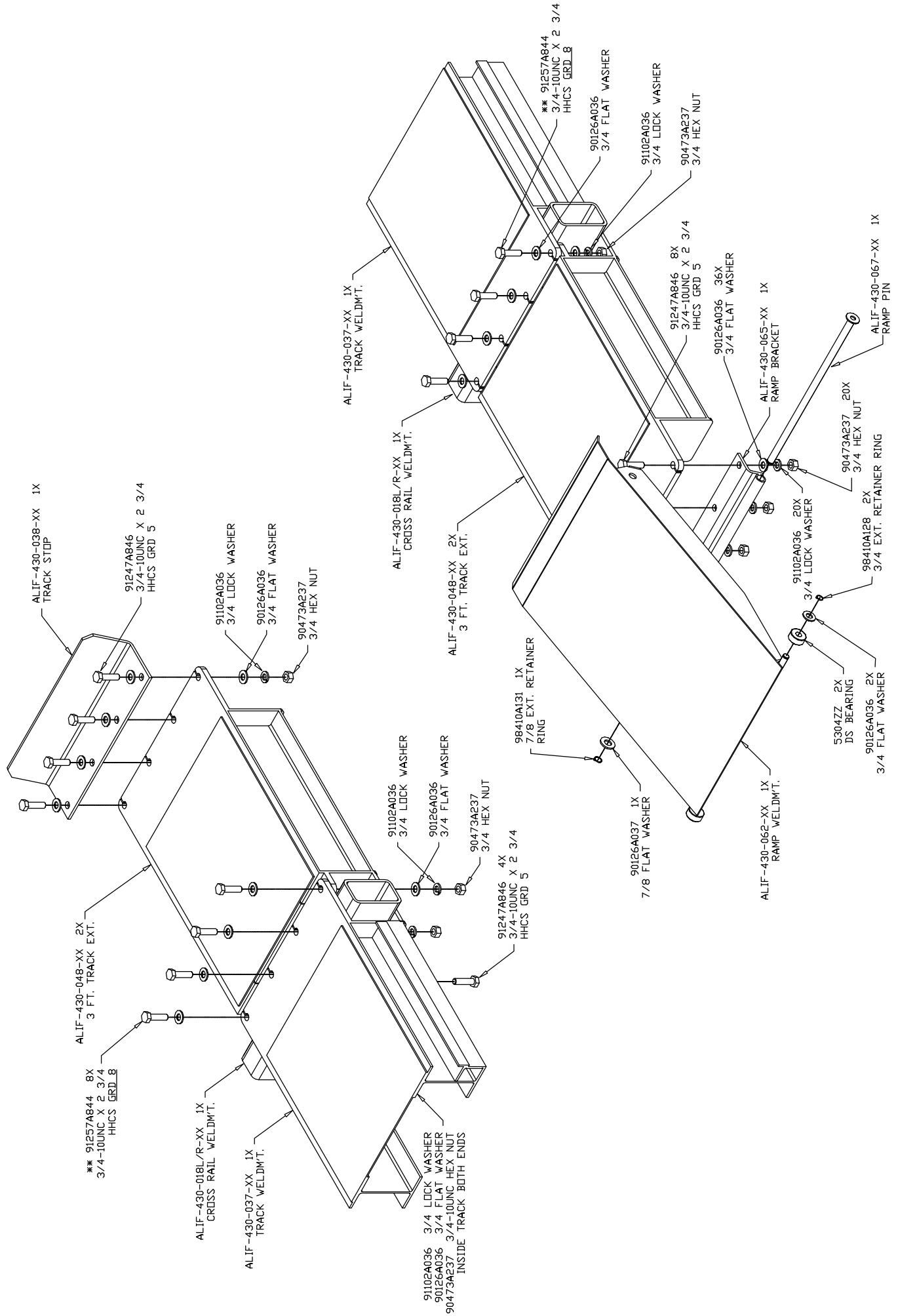
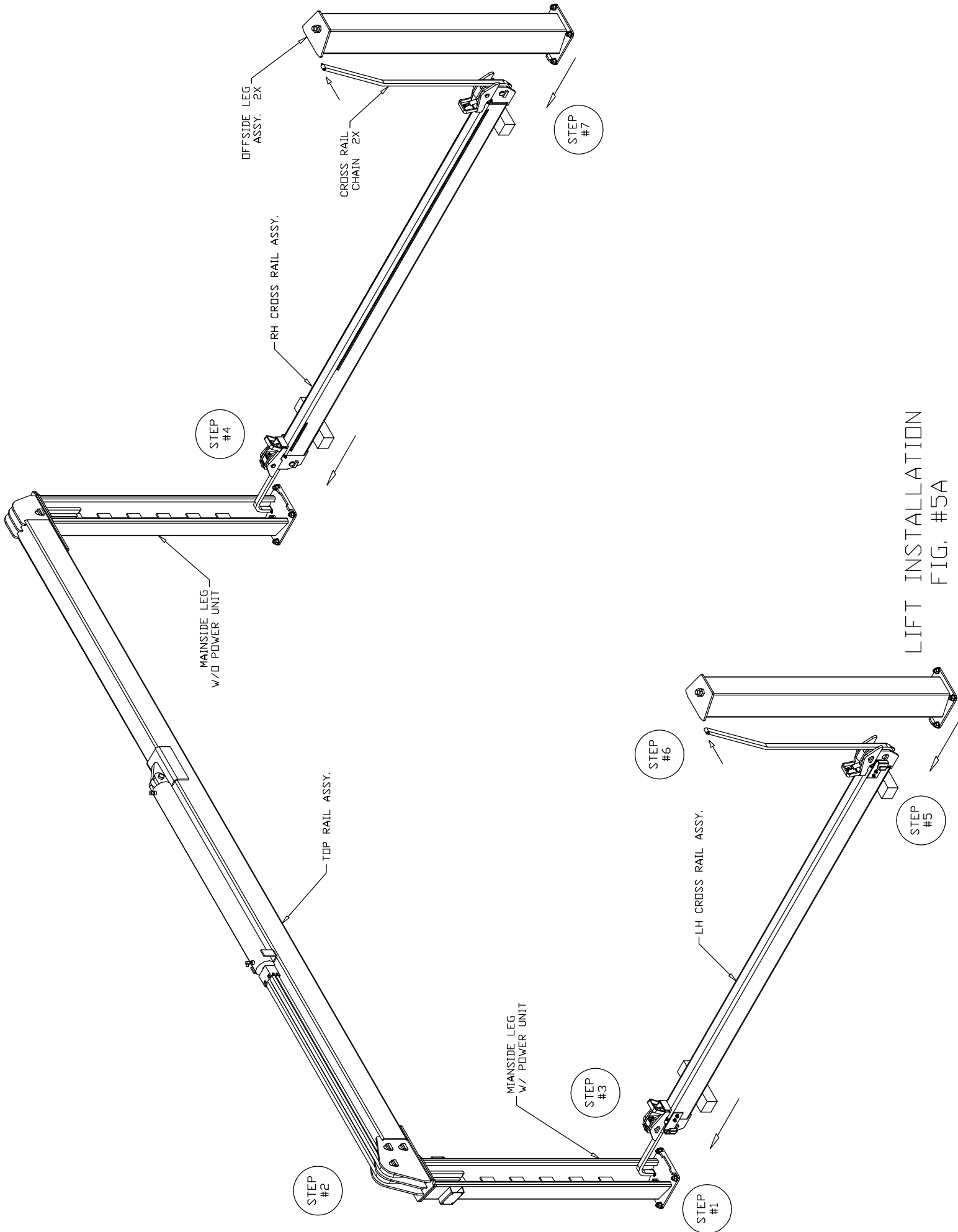

FIG. #4B



LIFT INSTALLATION
FIG. #5A

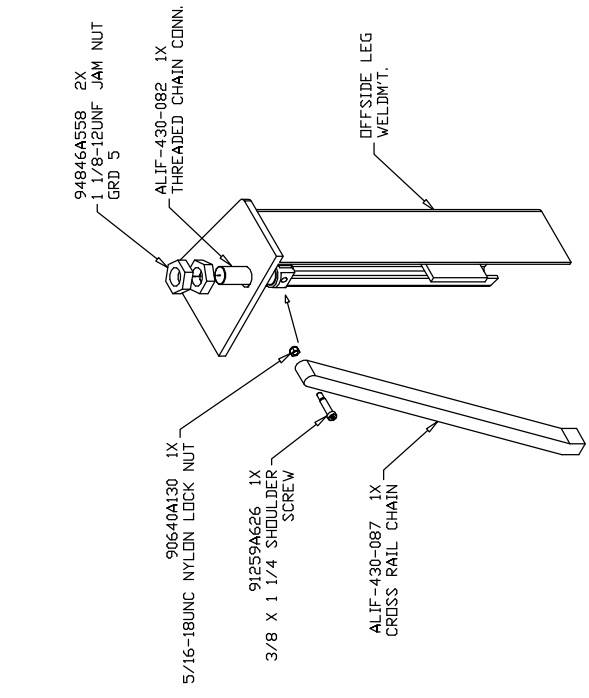

FIG. #5D

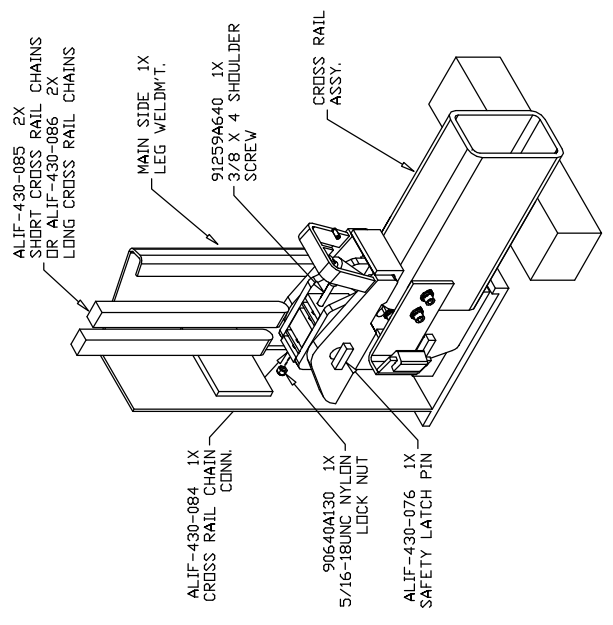

FIG. #5E

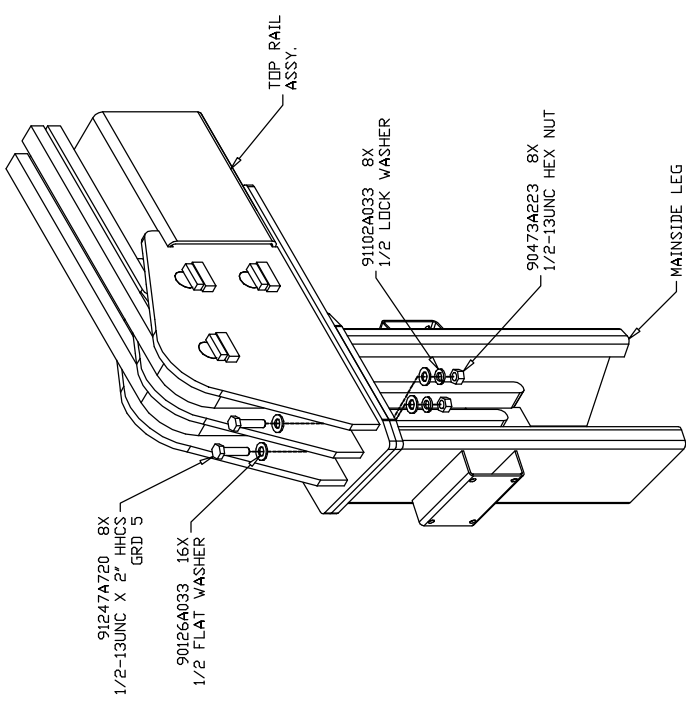

FIG. #5B

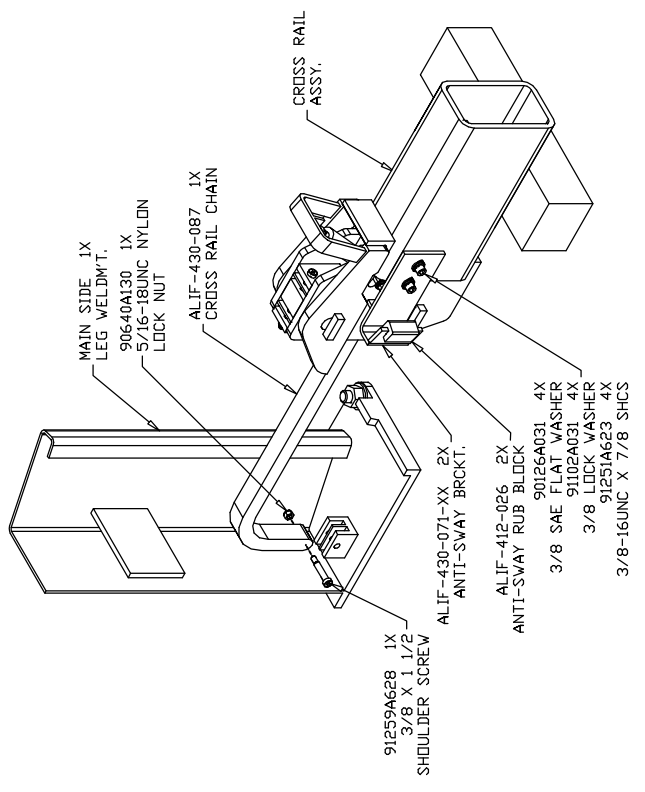

FIG. #5C

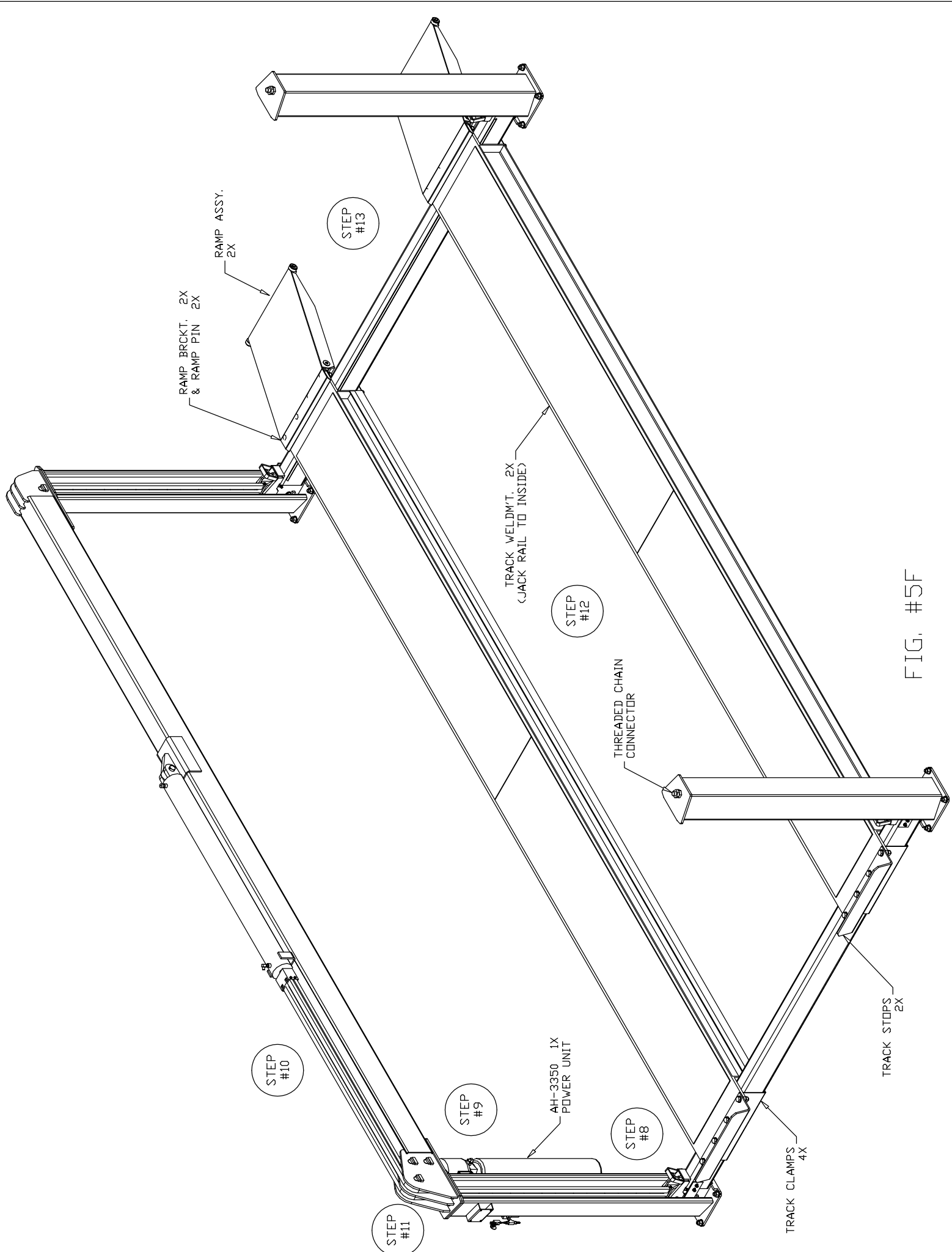

FIG. #5F

HYDRUALIC & PNUEMATIC ASSEMBLY

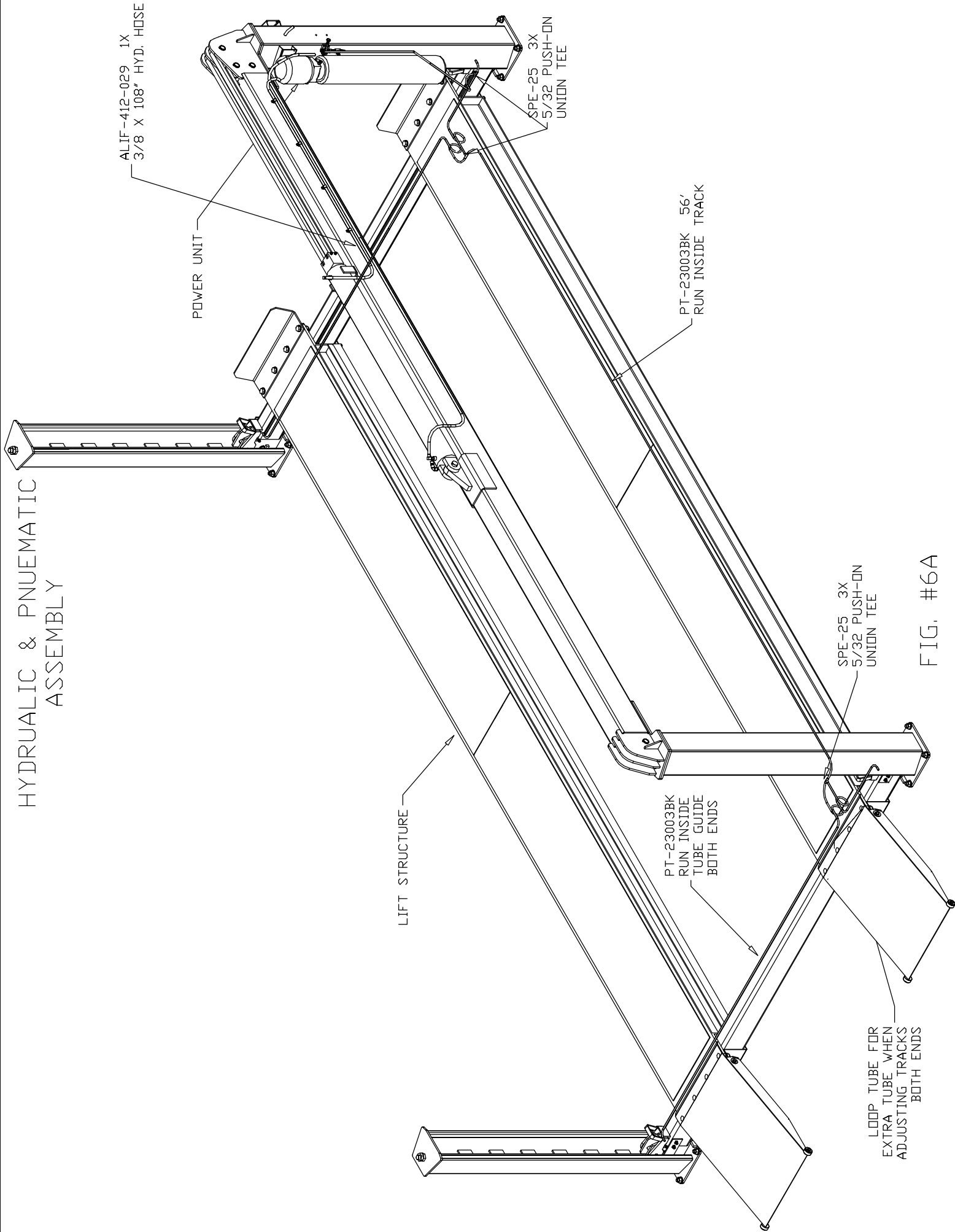
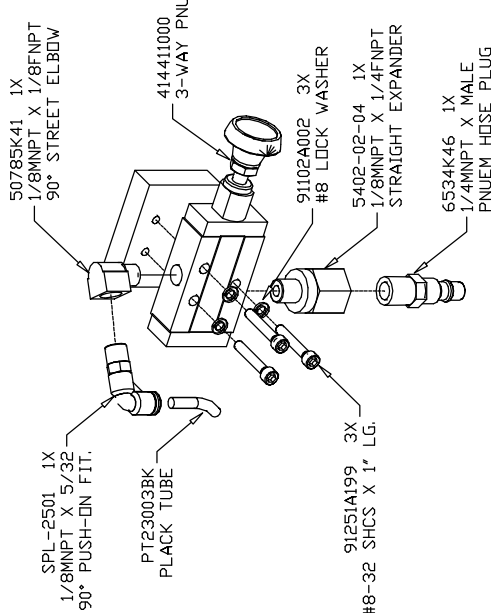
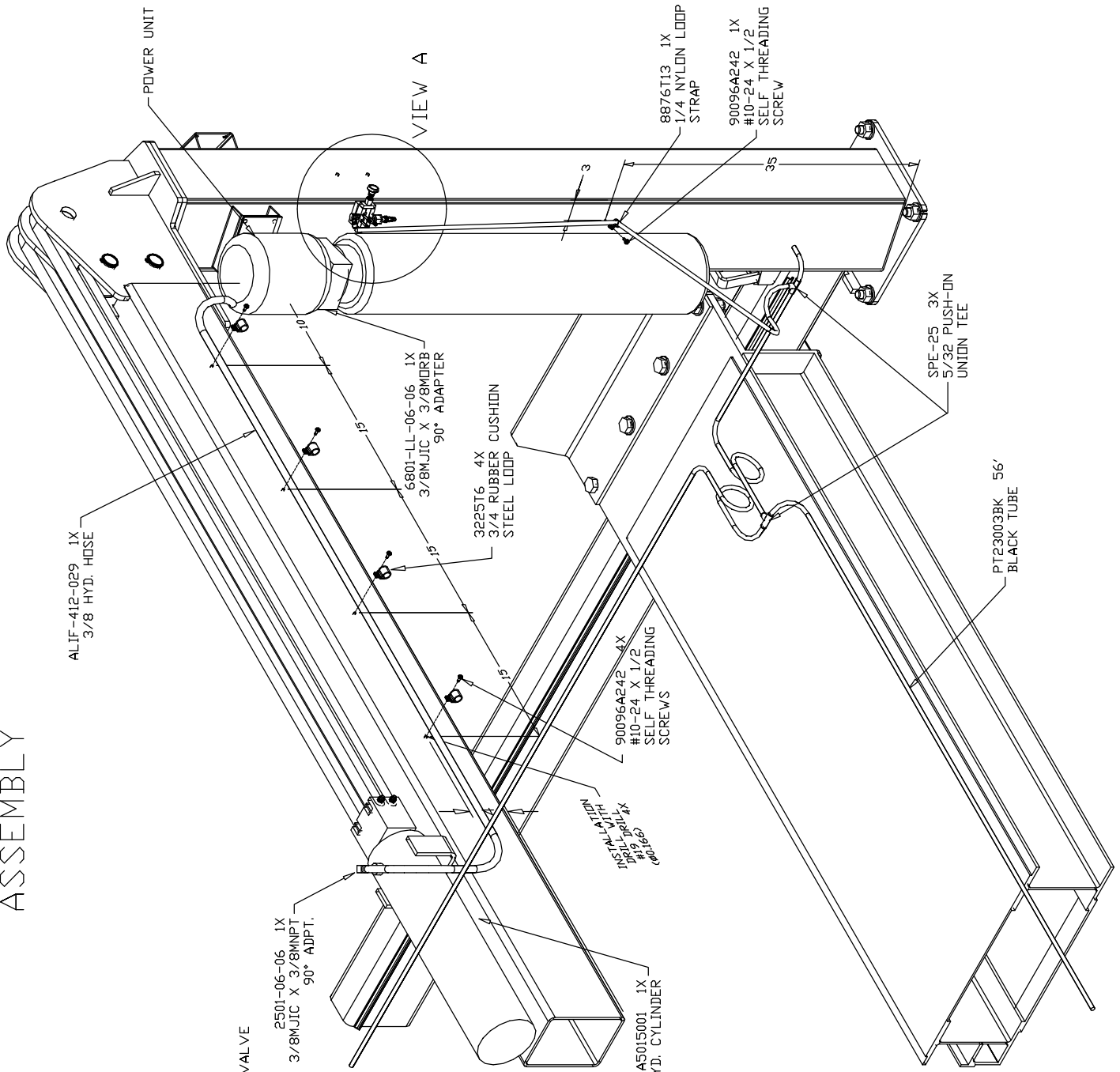

FIG. #6A

HYDRUALIC & PNUEMATIC ASSEMBLY



VIEW A

VIEW A

FIG. #6B